



BRAND

PureEdge Lighting

DESCRIPTION

Monorail 2-circuit flexible conductive connectors join and electrically conduct two sections of 2-circuit Monorail at any angle from 45 to 180 degree horizontal or vertical plane. Finish available in satin nickel, polished nickel or antique bronze. ETL listed.



SHADE COLOR	N/A
BODY FINISH	Satin Nickel
WATTAGE	N/A
DIMMER	N/A
DIMENSIONS	1.28"W
LAMP	N/A

SPEC # EDG50279

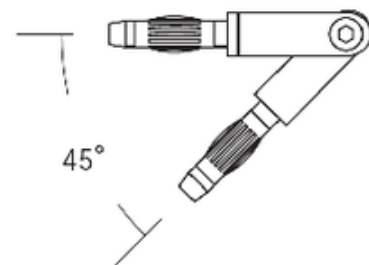
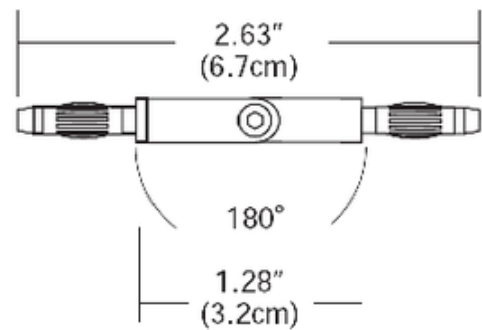

COMPANY	PROJECT	FIXTURE TYPE	APPROVED BY	DATE