

Installation Instructions for Monorail 2"-96" Rigid Standoffs

IMPORTANT INFORMATION

- This product is ETL listed for indoor dry locations.
- The product is intended to be used with Edge Lighting Monorail systems only.
- Use Monorail standoffs where the Monorail sections join together and approximately every 3 feet max throughout the Monorail run.

SAVE THESE INSTRUCTIONS!

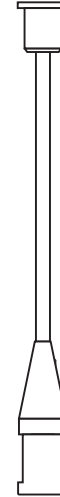

Install the Standoff

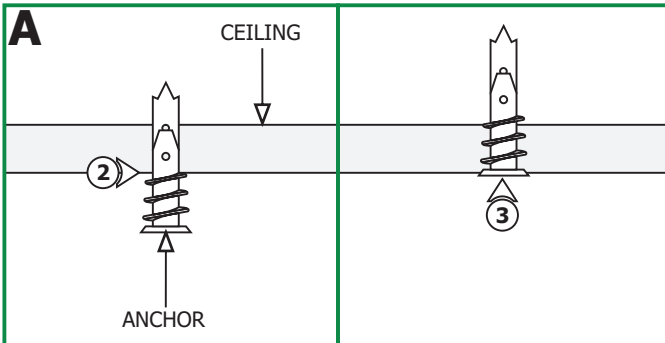

- 1: Hold the Monorail section against the ceiling or use a plumb bob to mark the standoff locations onto the ceiling (this may require more than one person).
- 2: Tap the anchors onto the marked locations up to the threaded portion with a hammer.
- 3: Screw the threaded portion of the anchors in with a Phillips screwdriver.

- 4: Mount the integrated washer-nipple to the anchor with the #8 screw provided.
- 5: Tighten the threaded post completely onto the integrated washer-nipple.

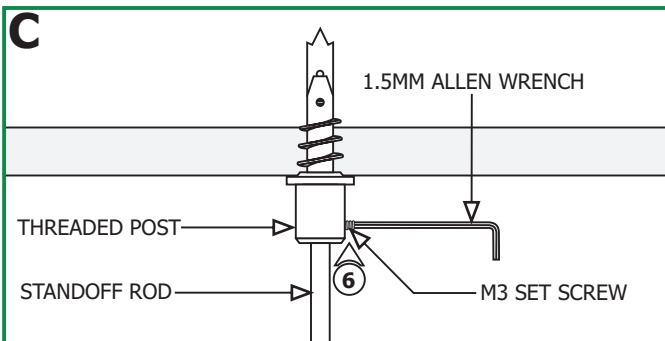
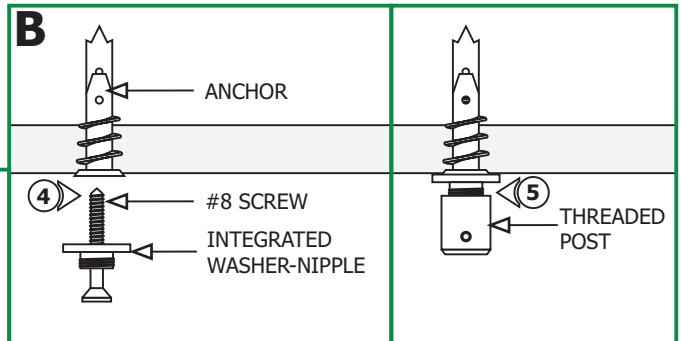

- 6: Push the standoff rod completely into the threaded post and tighten the M3 set screw with the 1.5mm Allen wrench.
- 7: Repeat steps 4 through 6 for the remaining standoffs.

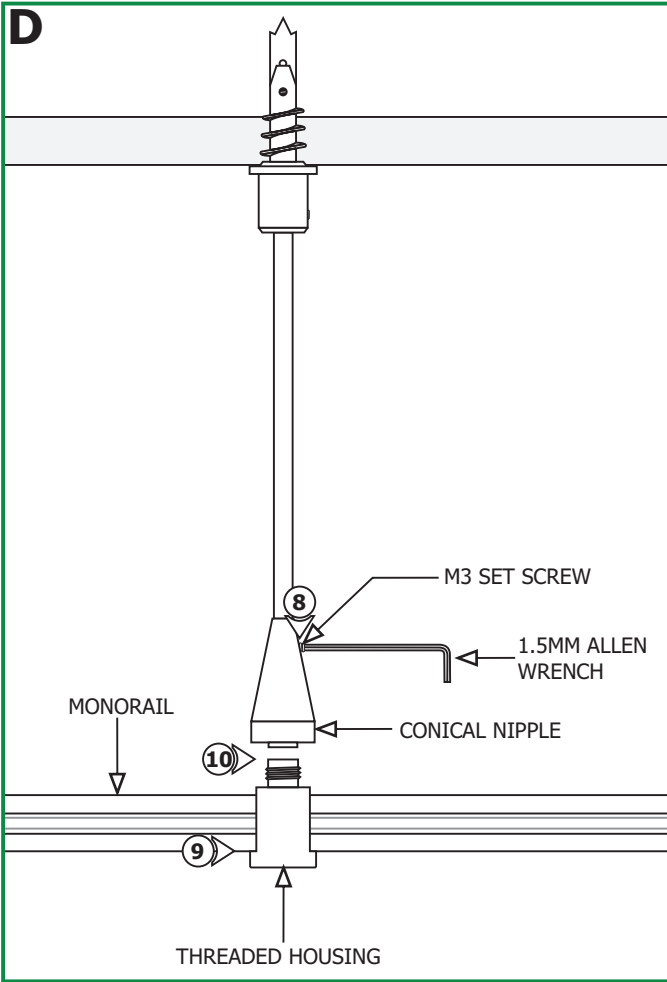

8: Slightly loosen the M3 set screw on the conical nipple of each of the standoffs with the 1.5mm Allen wrench so that the conical nipples can rotate easily.

9: Place the Monorail into the threaded housings (this may require more than one person).

10: Tighten the threaded housings to the conical nipples (this may require more than one person). **Make sure threaded housings are not cross threaded.**

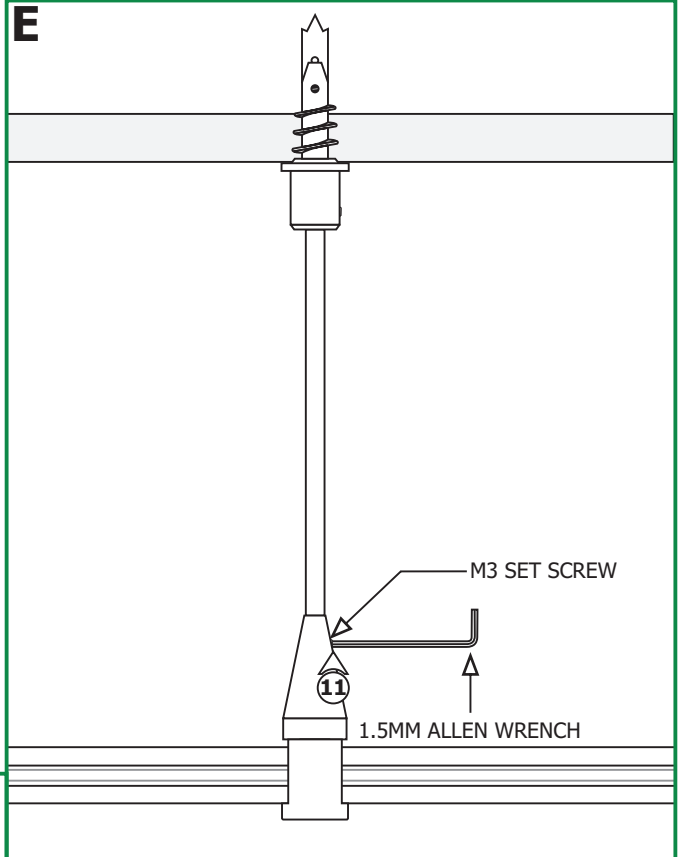

11: Tighten the M3 set screw on the conical nipples with the 1.5mm Allen wrench.