

Installation Instructions for Cirrus Channel Suspension D1, Direct 1" Lens

IMPORTANT INFORMATION

- This product is suitable for indoor locations.
- This instruction shows a typical installation.

SAVE THESE INSTRUCTIONS!



Connecting the Channel

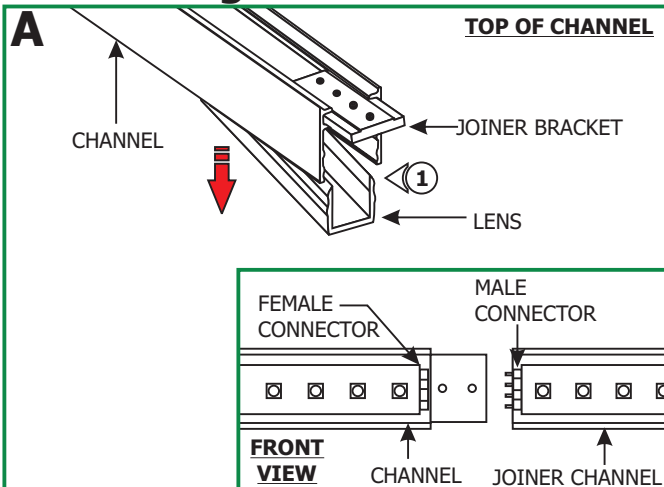

- NOTE:** Omit this section if the channel is made out of a single piece (120" or less).
- NOTE:** Prior to installation, multi-sectional Cirrus Channel should be connected together for marking proper measurements.
- NOTE:** It is recommended more than one person to assist in this installation.

- 1: Lift a section of the lens at the end of the channels where the connectors are visible. Slide the channel over the joiner bracket and ensure the male & female connectors mate properly.
- 2: Push the lens back into the channel.

NOTE: When using Edge Lighting Slim Profile Junction Box (C-1RE-BOX), continue to "Install the Channel using the Junction Box (C-1RE-JBOX)" on page 3.

- 3: Position the joiner bracket where the two channels meet. Tighten four #6-32 set screws using the 1/16 Allen wrench.

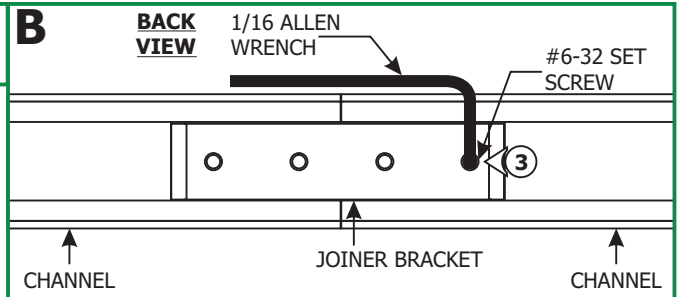

Adjusting Cable Position

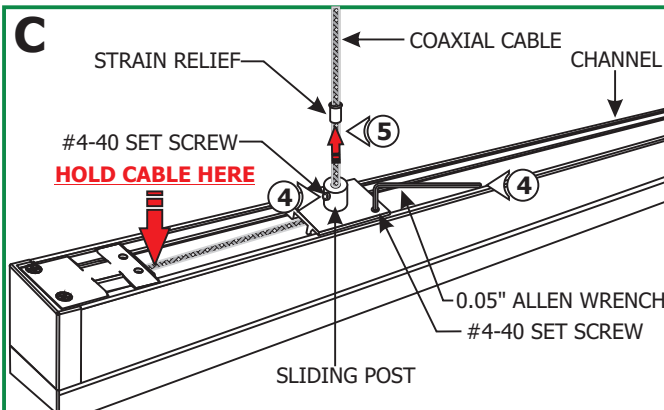

WARNING: To avoid damaging the coaxial cable electrical connection, make sure that the end of the coaxial cable coming out of the fixture is held with thumb before relocating sliding posts.

- 1: Loosen (DO NOT REMOVE) the #4-40 set screw on the sliding post bushing and bed with a 0.05" Allen wrench.
- 2: Slide the strain relief tube out of the sliding post using a pair of needle-nose pliers.

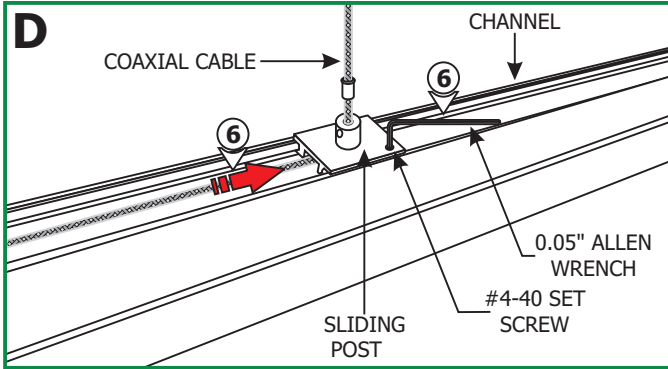

6: Carefully move the sliding post to the predetermined location on channel and tighten the #4-40 set screw on the sliding post bed with the 0.05" Allen wrench.

!CAUTION! Tightening the strain relief set screw **CANNOT BE REVERSED**. Only tighten the set screw **AFTER** the cable location is set properly.

7: Insert the strain relief tube back inside the sliding post bushing and tighten the #4-40 set screw with the 0.05" Allen wrench.

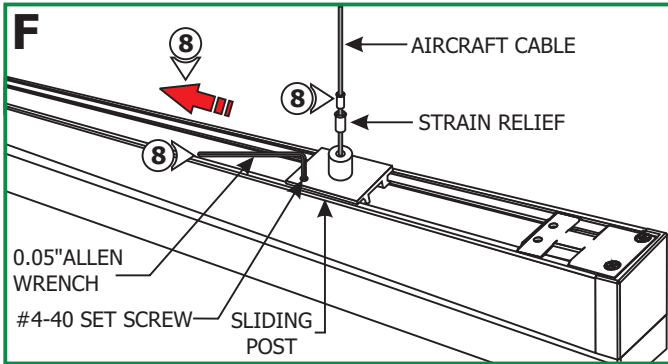
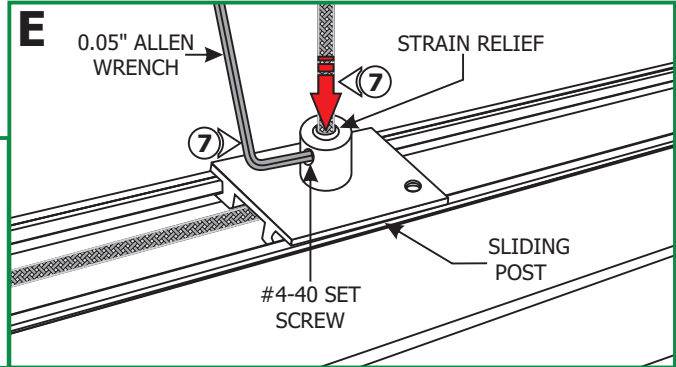

8: Repeat Steps 4 through 7 for aircraft cable side. Note that there are two intermating strain relief tubes.

Install the Fixture

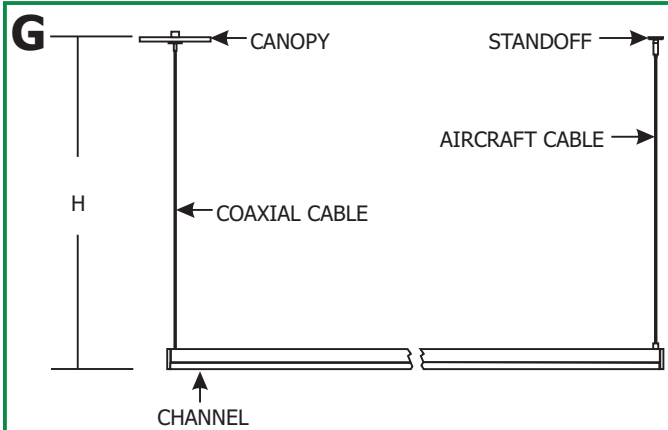

NOTE: Run the proper size wires between the 24VDC power supply to the electrical box. Refer to the instructions provided with the power supply for additional information. See the wiring diagram on page 2.

- 1: Measure the distance between the coaxial cable and the aircraft cable mounted on the channel. This measurement varies on the fixture length.
- 2: Mark the standoff location from the center of the electrical box for the distant achieved on step 1.

- 3: Tap the anchors onto the marked points up to the threaded portion with a hammer.
- 4: Screw in the threaded portion of the anchors with a Phillips screwdriver.

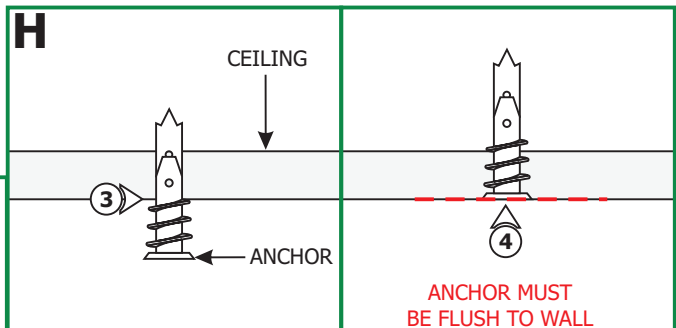

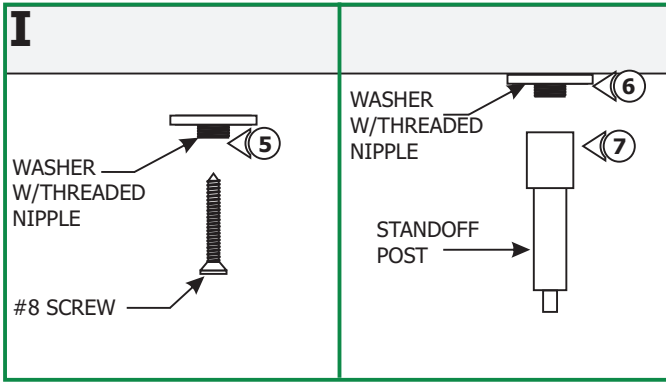

- 5:** Feed the #8 screw through the washer w/threaded nipple into the anchor.
- 6:** Tighten the #8 screw completely into the anchor.
- 7:** Tighten the standoff posts completely onto the threaded nipple.

- 8:** Push the tab on standoff while feeding the aircraft cable coming from the channel into a standoff so that it holds one end of the fixture in place.

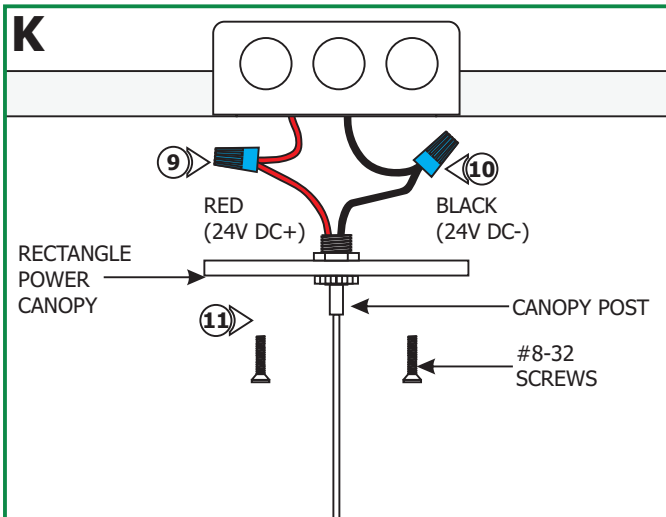
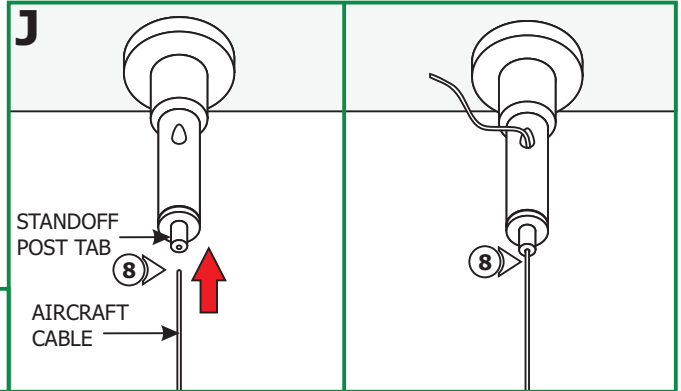

- 9:** Connect the red (24V DC+) power supply wire to the red canopy wire with a wire nut.
- 10:** Connect the black (24V DC-) power supply wire to the black canopy wire with a wire nut.
- 11:** Line up the canopy with the electrical box, and secure it in place by tightening the two #8-32 screws provided.

Height Adjustments

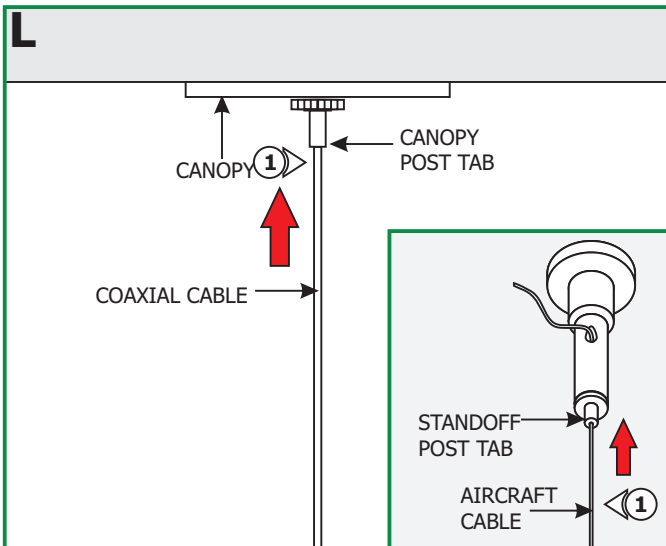

- 1:** Adjust the fixture height by pushing the aircraft cable & coaxial cable in to the standoff posts & canopy post.
- 2:** If necessary push the tab on the standoffs & canopy post to release the wire.

96W, 24VDC LOW VOLTAGE WIRE SIZE CHART

3% VOLTAGE DROP	WIRE LENGTH IN FT	UP TO 33FT	34FT-52FT	53FT-86FT	87FT-130FT
	WIRE SIZE	14 AWG	12 AWG	10 AWG	8 AWG
	VOLTAGE AT END OF THE WIRE	23.28 VDC	23.29 VDC	23.28 VDC	23.28 VDC

GENERAL WIRING DIAGRAM

