

## Installation Instructions for Cirrus Channel Suspension T1, Tubular Lens w/2SQ or 2RD Canopy

### IMPORTANT INFORMATION

- This product is suitable for indoor locations.
- This instruction shows a typical installation.

**SAVE THESE INSTRUCTIONS!**



### Connecting the Channel

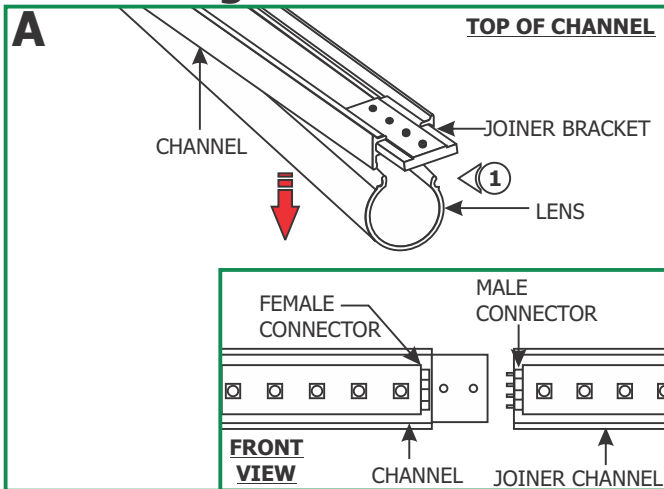

**NOTE:** Omit this section if the channel is made out of a single piece (120" or less).

**NOTE:** Prior to installation, multi-sectional Cirrus Channel should be connected together for marking proper measurements.

**NOTE:** It is recommended more than one person assist in this installation.

- 1: Lift a section of the lens at the end of the channels where the connectors are visible. Slide the channel over the joiner bracket make sure that the male & female connectors mate properly.

- 2: Push the lens back into the channel.

**NOTE:** When using Edge Lighting Slim Profile Junction Box (C-1RE-BOX), continue to "Install the Channel using the Junction Box (C-1RE-JBOX)" on page 3.

- 3: Position the joiner bracket where the two channels meet. Tighten four #6-32 set screws using the 1/16 Allen wrench.

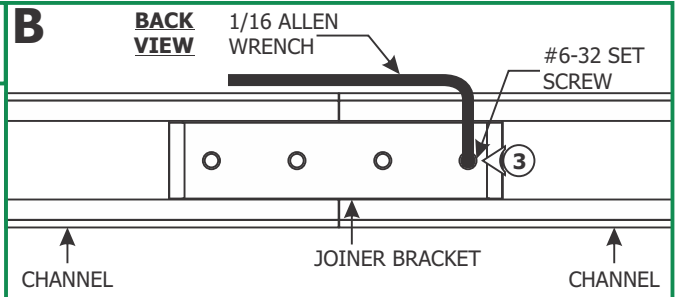

### Adjusting Cable Position

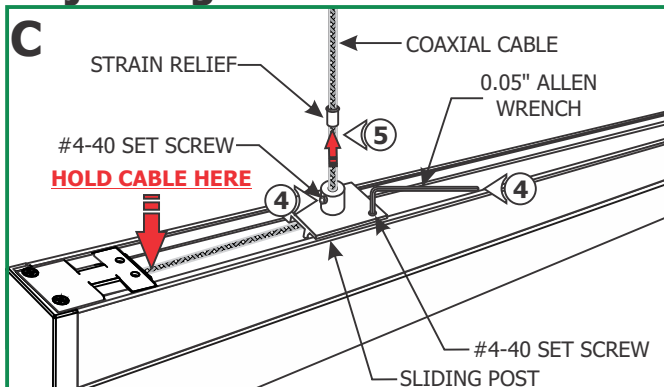

**WARNING:** To avoid damaging the coaxial cable electrical connection, make sure that the end of the coaxial cable coming out of the fixture is held with thumb before relocating sliding posts.

- 4: Loosen (DO NOT REMOVE) the #4-40 set screw on the sliding post bushing and bed with a 0.05" Allen wrench.

- 5: Slide the strain relief tube out of the sliding post using a pair of needle-nose pliers.

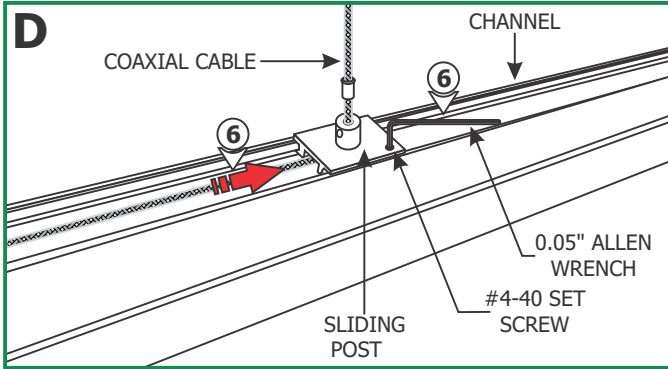

**6:** Carefully move the sliding post to the predetermined location on channel and tighten the #4-40 set screw on the sliding post bed with the 0.05" Allen wrench.

**!CAUTION!** Tightening the strain relief set screw **CANNOT BE REVERSED**. Only tighten the set screw **AFTER** the cable location is set properly.

**7:** Insert the strain relief tube back inside the sliding post bushing and tighten the #4-40 set screw with the 0.05" Allen wrench.

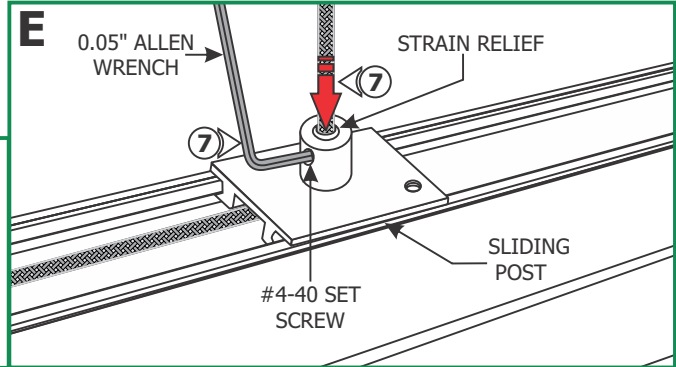

**8:** Repeat Steps 4 through 7 for aircraft cable side. Note that there are two intermating strain relief tubes.

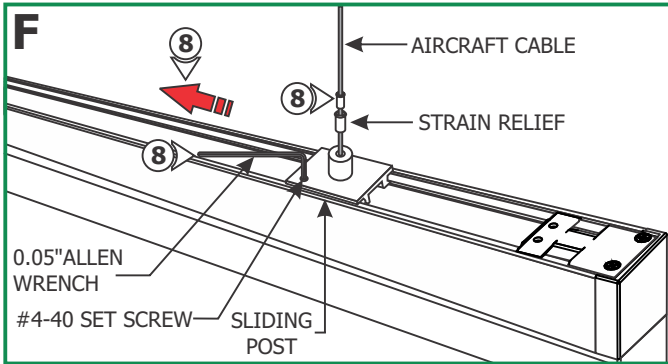

## Install the Fixture

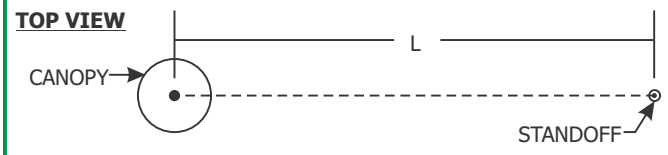
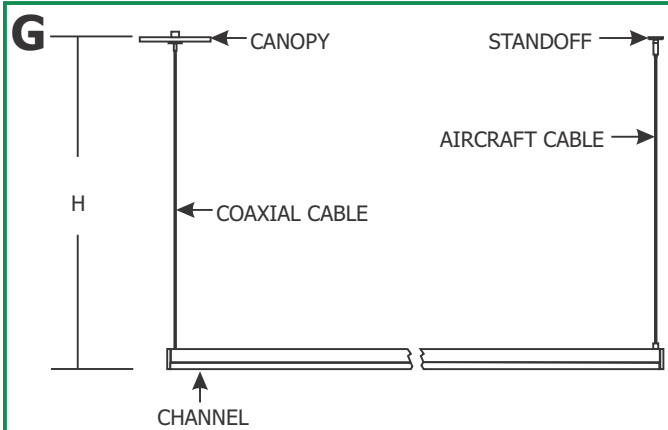

**NOTE:** Run the proper size wires between the 24VDC power supply to the electrical box. Refer to the instructions provided with the power supply for additional information. See the wiring diagram on page 2.

- 1: Measure the distance between the coaxial cable and the aircraft cable mounted on the channel. This measurement varies on the fixture length.
- 2: Mark the standoff location from the center of the electrical box for the distant achieved on step 1.

- 3: Tap the anchors onto the marked points up to the threaded portion with a hammer.
- 4: Screw in the threaded portion of the anchors with a Phillips screwdriver.

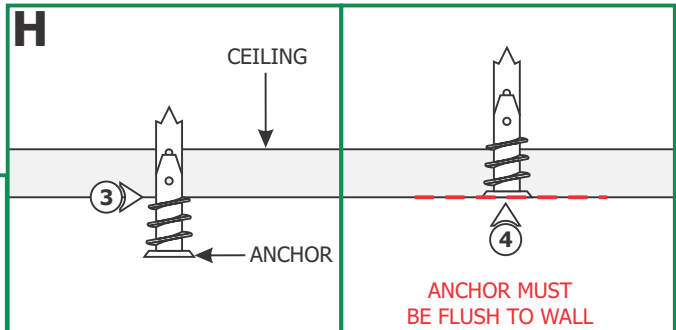

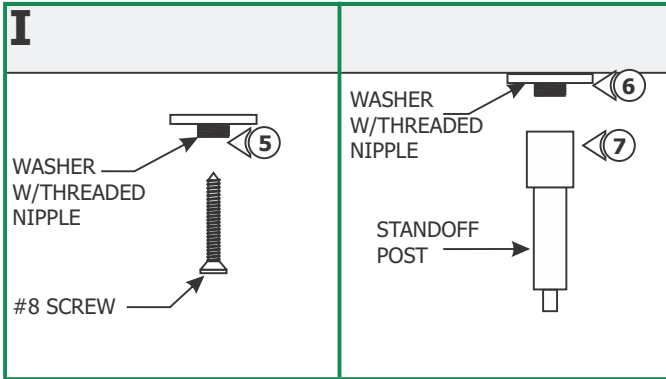

**5:** Feed the #8 screw through the washer w/threaded nipple into the anchor.

**6:** Tighten the #8 screw completely into the anchor.

**7:** Tighten the standoff posts completely onto the threaded nipple.

**8:** Push the tab on standoff while feeding the aircraft cable coming from the channel into a standoff so that it holds one end of the fixture in place.

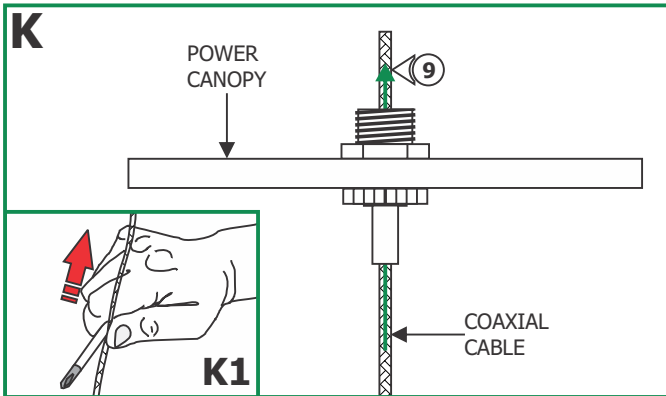
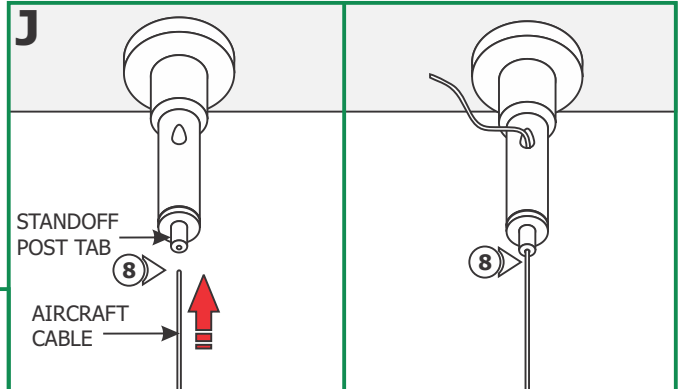

**9:** Feed the coaxial cable through the power feed canopy.

**NOTE:** If cable is curled or kinked, straighten by holding between the shaft of a screwdriver and thumb and pulling the cable through (see inset **K1**)

**10:** Using the 18 AWG hole of the wire strippers, remove 1" of the outer braided wire.

**11:** Using the 20 AWG hole of the wire strippers, remove 1/8" of inner plastic insulation from the end of the coaxial cable.

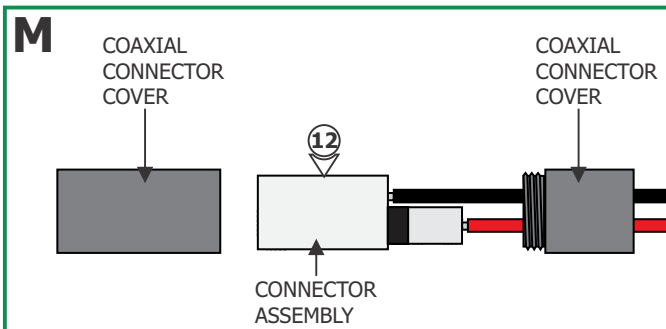
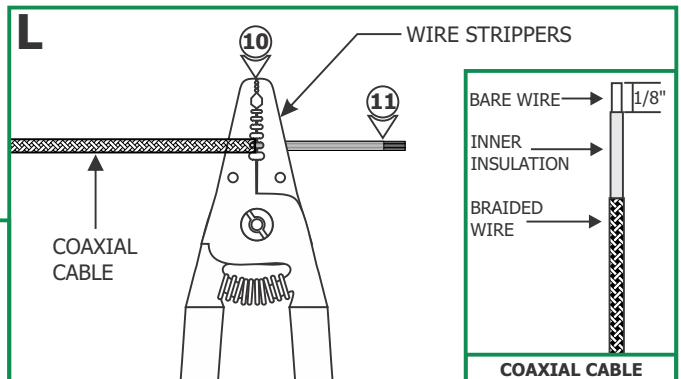

**12:** Unscrew the coaxial connector covers and remove from the connector assembly.

**13:** Using the provided 1.5mm Allen Wrench, remove the M3 set screw from the coaxial connector assembly.

**14:** Using the provided 2mm Allen wrench to loosen (do not remove) the M4 set screw.

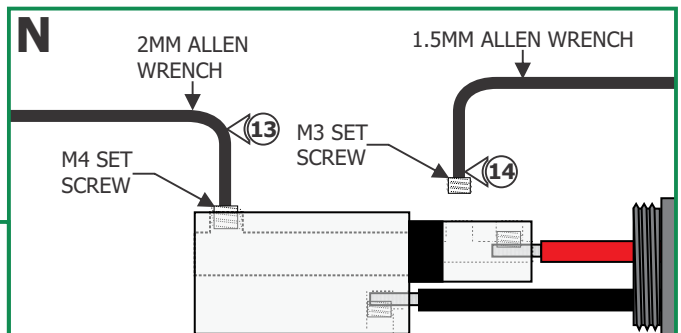

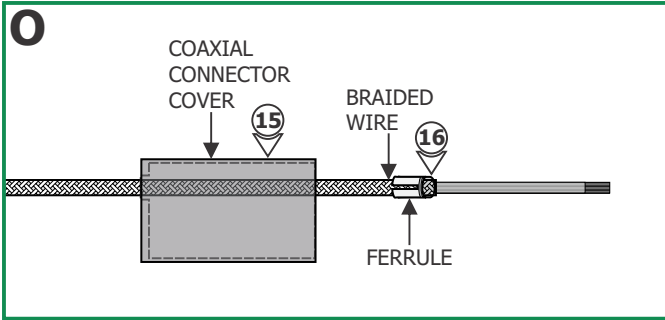

**15:** Slide the connector cover over the coaxial cable.

**16:** Place the ferrule over the braided wire of the coaxial cable.

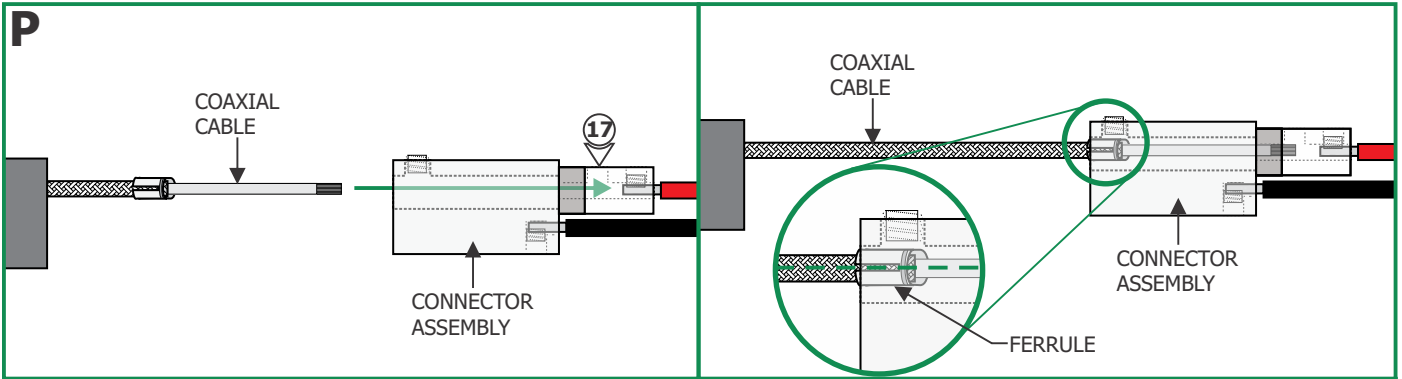

**17:** Insert the coaxial cable into the coaxial connector until the wires of the center conductor are visible through the M3 set screw hole.

**NOTE:** Ensure that the split in the ferrule is aligned 90° from the M4 set screw (see inset).

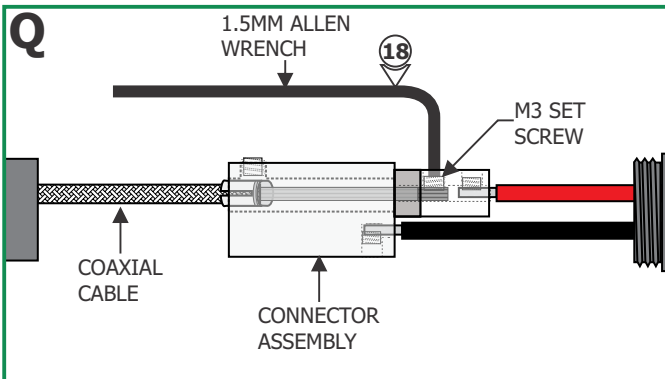

**18:** Use the provided 1.5mm Allen wrench to replace and securely tighten the M3 set screw.

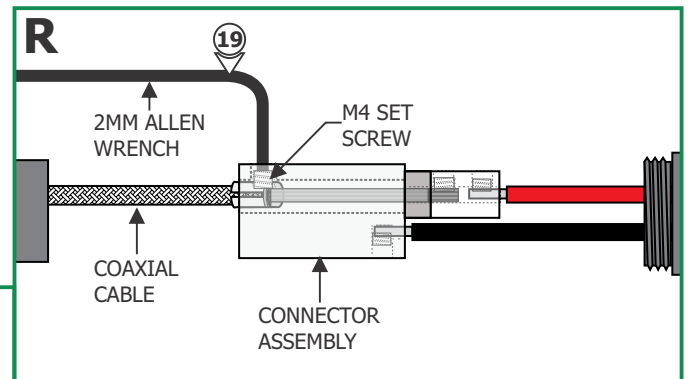

**19:** Use the provided 2mm Allen wrench to securely tighten the M4 set screw until it squeezes the wire ferrule tightly to the coaxial cable.

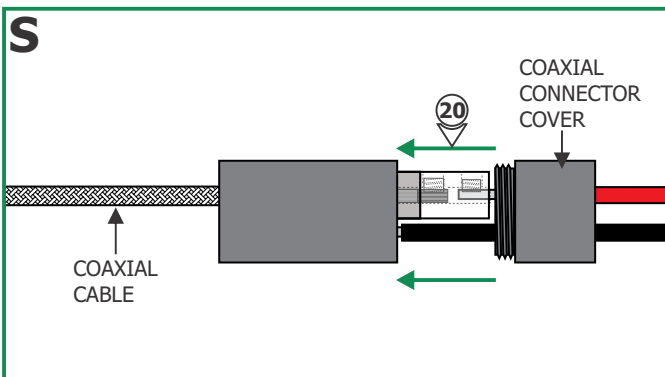

**20:** Replace the coaxial connector cover and tighten into place.

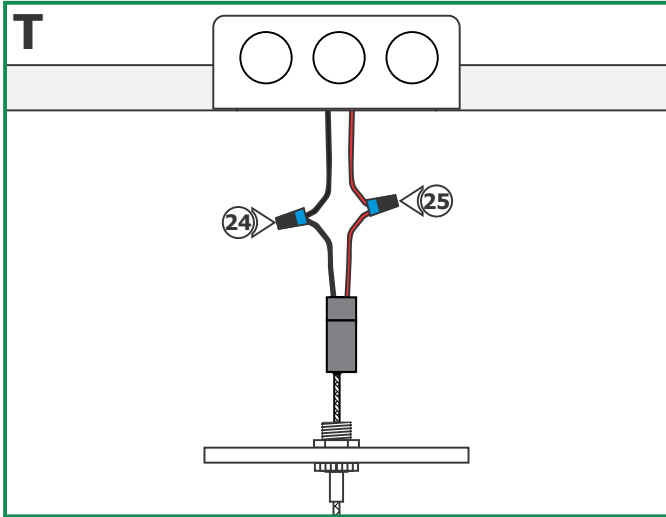

**NOTE:** Ensure remote DC power supply wires are present in the junction box before continuing.

**24:** Connect the black remote power supply wire to the black coaxial connector wire using a wire nut.

**25:** Connect the black remote power supply wire to the black coaxial connector wire using a wire nut.

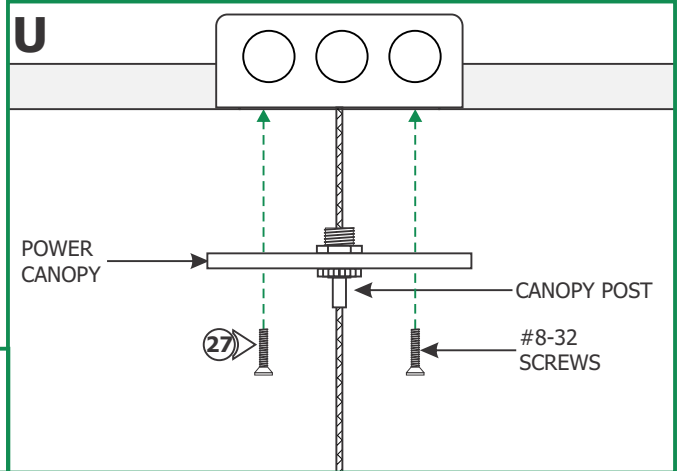

**26:** Place all connections into the junction box.

**27:** Secure the power canopy to the junction box using two #8-32 screws.

## Height Adjustments

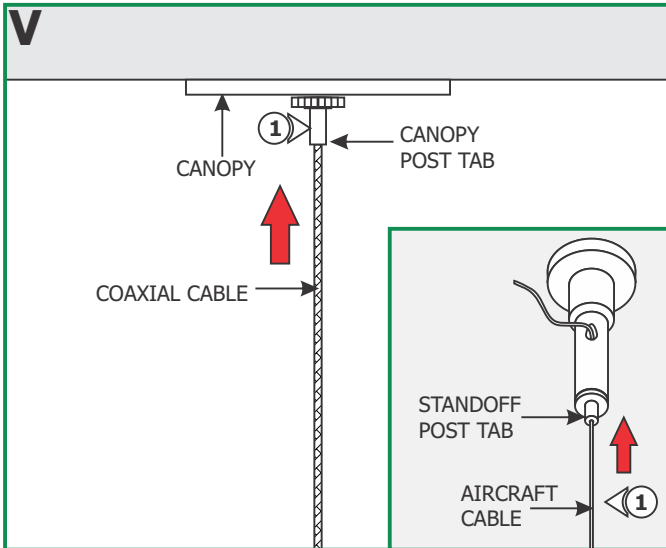

**1:** Adjust the fixture height by pushing the aircraft cable & coaxial cable in to the standoff posts & canopy post.

**2:** If necessary push the tab on the standoffs & canopy post to release the wire.

**96W, 24VDC LOW VOLTAGE WIRE SIZE CHART**

3% VOLTAGE DROP	WIRE LENGTH IN FT	UP TO 33FT	34FT-52FT	53FT-86FT	87FT-130FT
	WIRE SIZE	14 AWG	12 AWG	10 AWG	8 AWG
	VOLTAGE AT END OF THE WIRE	23.28 VDC	23.29 VDC	23.28 VDC	23.28 VDC

### GENERAL WIRING DIAGRAM

