

Installation Instructions for Cirrus Float D1 For Fast Jack, Monorail, and Monorail Two Circuit

IMPORTANT INFORMATION

- This product is suitable for indoor dry locations.
- This instruction shows typical installation for Fast Jack canopies, Monorail, and Monorail Two Circuit.
- For installation on T-Bar Clip use the Cirrus T-Bar clip instructions (904-CS-TBAR) concurrently with these instructions.

SAVE THESE INSTRUCTIONS!



Install the Fast Jack Connector to Coaxial Power Cable

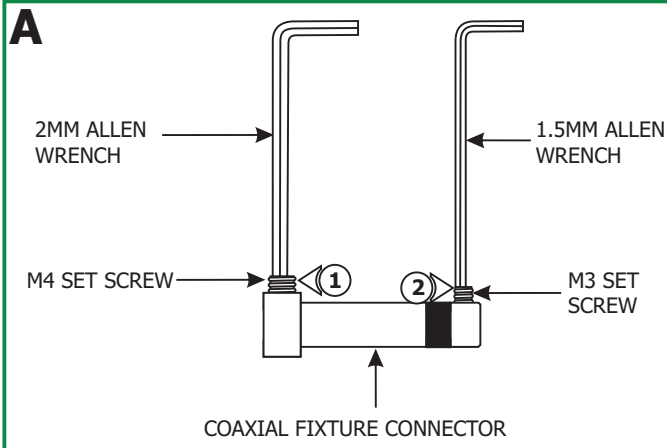

1: Loosen the M4 set screw on base of the coaxial fixture connector with the 2mm Allen wrench provided. **Do not remove this set screw.**

2: Remove the M3 set screw on tip of the connector with the 1.5mm Allen wrench provided.

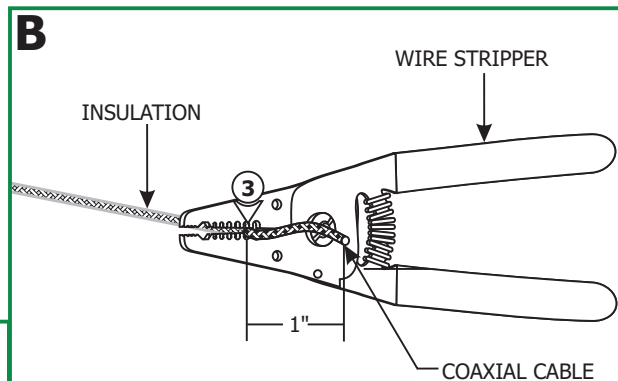

3: Use the #12 gauge hole of the AWG wire strippers to strip 1" of the insulation cover from the end so that the bare coaxial cable is exposed.

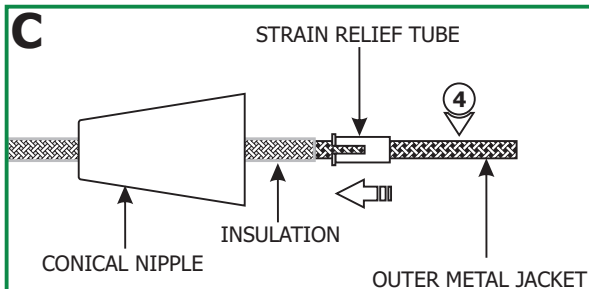

4: Feed the coaxial cable through the conical nipple and flared side of the strain relief tube. Slide the conical nipple down the coaxial cable. Slide the strain relief tube against the insulation.

5: Use the #14 gauge hole of the AWG wire strippers to strip the outer metal jacket exposed behind the strain relief tube.

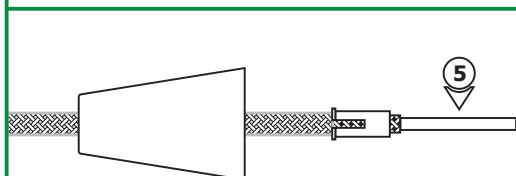

6: Feed the inner coaxial cable along with strain relief tube into the coaxial fixture connector.

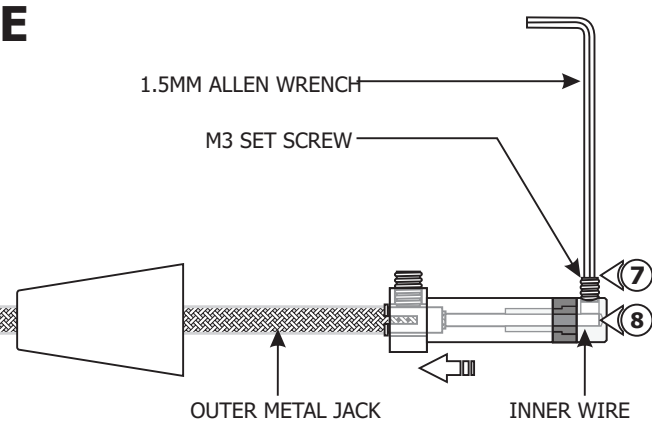
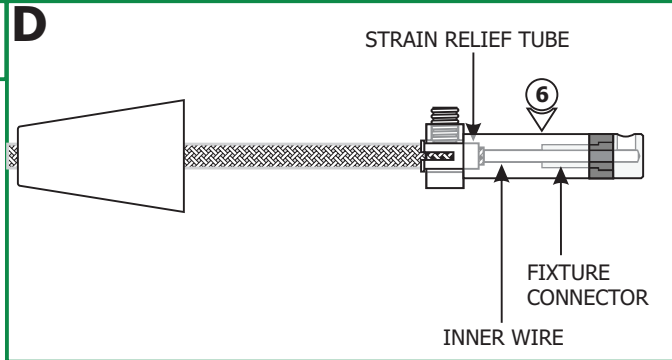

7: Keep feeding the coaxial cable in until the inner wire is visible in the screw hole of the fixture connector tip.

8: Hold the fixture connector and coaxial cable in place. Replace and tighten the M3 set screw on fixture connector tip with the 1.5mm Allen wrench.

9: Make sure the strain relief tube is completely into the coaxial fixture connector and the slot on the strain relief tube is not inline with the M4 set screw.

10: Tighten the M4 set screw with the 2mm Allen wrench

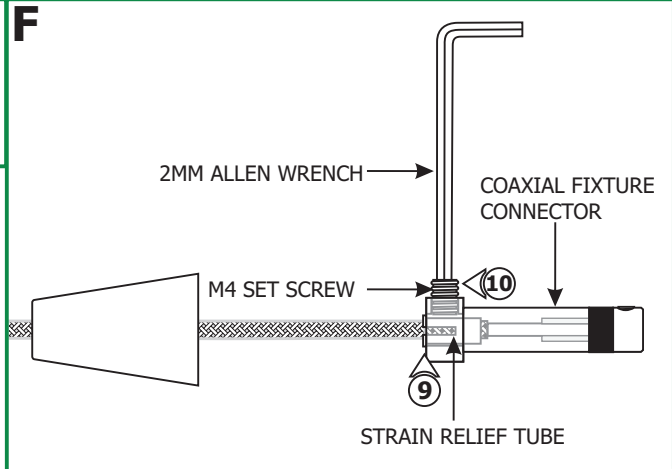

Install Cirrus Float to Two Port Fast Jack 26" Rectangle Canopy (FJP-26RE-XX)

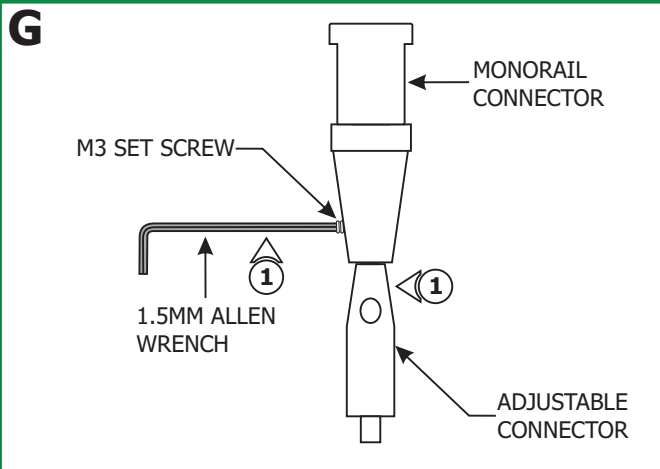

NOTE: Make sure the Fast Jack Canopy is installed. One of the Fast Jack ports will be used as a support post and the other will power the fixture. The center distance between the Fast Jack ports is 14". Depending on the fixture length, the coaxial and aircraft cable posts on the fixture will need to be moved towards the center so that they are 14" apart.

1: Loosen the M3 set screw on the adjustable post with the 1.5mm Allen wrench to remove the adjustable connector from the Monorail connector.

- 2:** Screw the conical post provided with the fixture hardware completely on to one of the Fast Jack ports.
- 3:** Insert the adjustable connector completely into the conical post and tighten the M3 set screw with the 1.5mm Allen wrench.

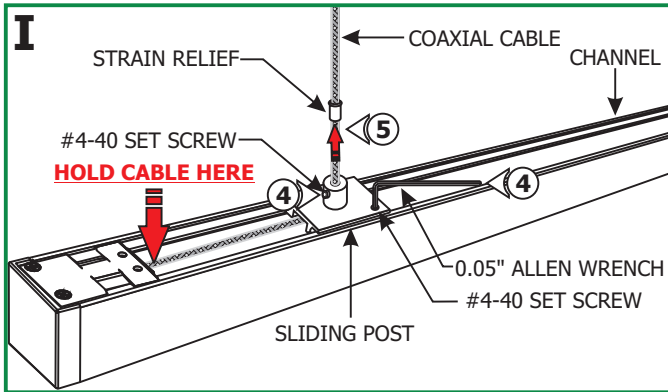
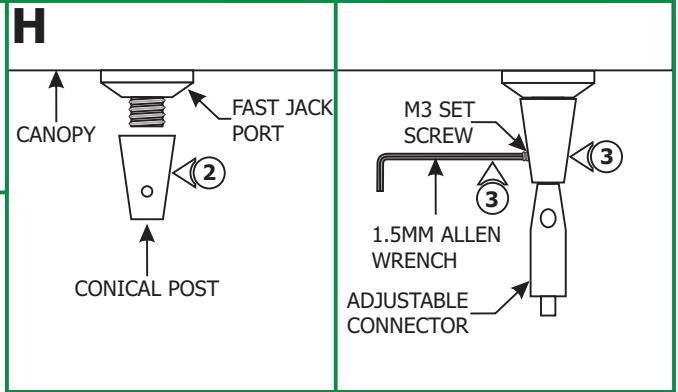

- WARNING:** To avoid damaging the coaxial cable electrical connection, make sure that the end of the coaxial cable coming out of the fixture is held with thumb before relocating sliding posts.
- 4:** Loosen (DO NOT REMOVE) the #4-40 set screw on the sliding post bushing and bed with a 0.05" Allen wrench.
 - 5:** Slide the strain relief tube out of the sliding post using a pair of needle-nose pliers.

- 6:** Carefully move the sliding post to the predetermined location on channel and tighten the #4-40 set screw on the sliding post bed with the 0.05" Allen wrench.

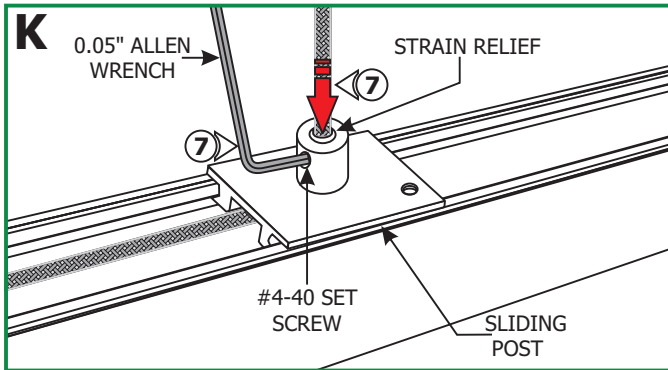
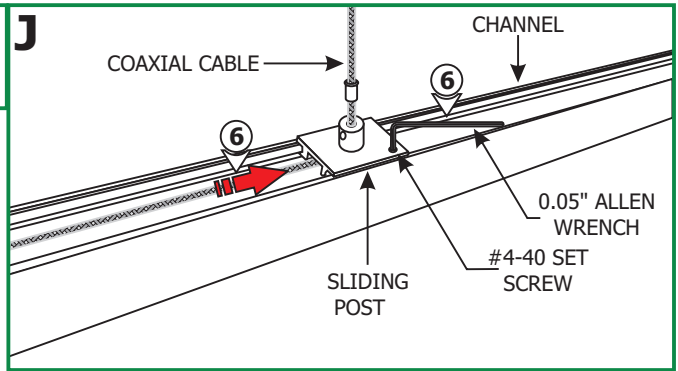

- !CAUTION!** Tightening the strain relief set screw **CANNOT BE REVERSED**. Only tighten the set screw **AFTER** the cable location is set properly.
- 7:** Insert the strain relief tube back inside the sliding post bushing and tighten the #4-40 set screw with the 0.05" Allen wrench.

- 8:** Repeat Steps 4 through 7 for aircraft cable side. Note that there are two intermating strain relief tubes.

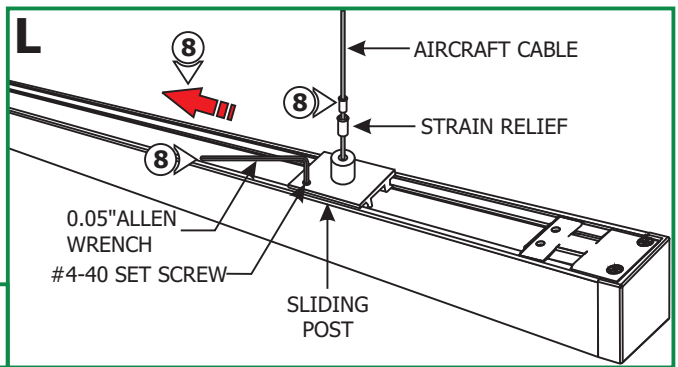

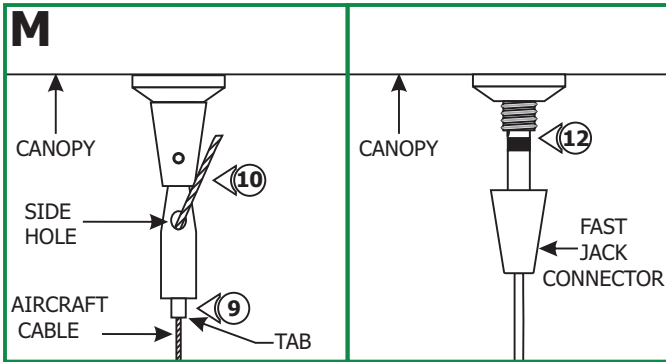

- 9:** Push the tab on the adjustable connector and feed the aircraft cable through the tab.
- 10:** Pull the aircraft cable coming out of the side of the adjustable connector.
- 11:** When desired height is achieved release the tab to lock the aircraft cable in place.
- 12:** Use fingers to tighten the Fast Jack fixture connector into the Fast Jack canopy.
- 13:** If necessary, repeat steps 9 through 11. Trim off excess aircraft cable coming out of the adjustable connector side hole for a neat finished look.

Install Cirrus Float to Single or Multi Port Fast Jack Canopies

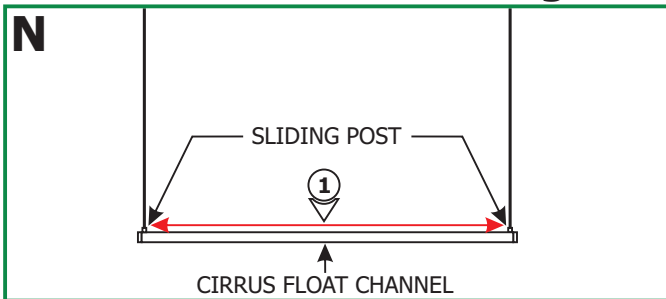

NOTE: Make sure that the Fast Jack canopy is installed.

- 1:** Measure the distance between the center of the coaxial cable post and the aircraft cable post. This measurement varies based on the fixture length. Use the measured distance to mark the location of the aircraft post onto the ceiling.

- 2:** Loosen the M3 set screw on the adjustable post with the 1.5mm Allen wrench to remove the adjustable connector from the Monorail connector.

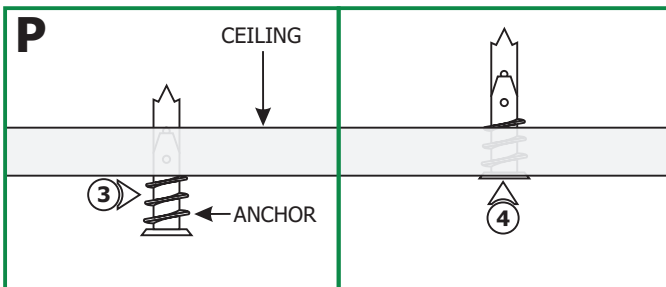
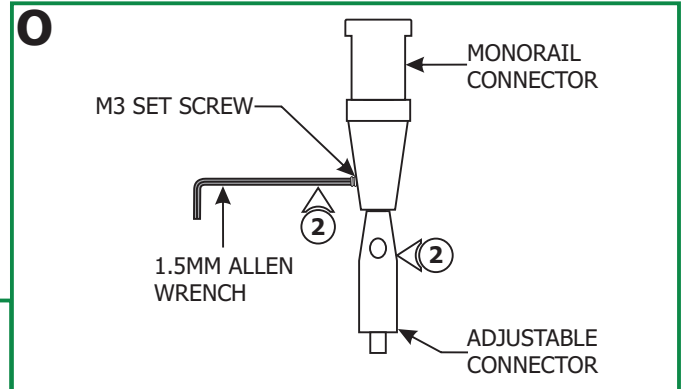

- 3:** Tap the anchors onto the marked locations up to the threaded portion with a hammer.
- 4:** Screw in the threaded portion of the anchors with a Phillips screwdriver.

- 5:** Feed the #8 screw through the countersink side of the threaded nipple and washer. **Make sure the side of the washer with deeper countersink is facing the anchor.**
- 6:** Tighten the #8 screw completely into the anchor.
- 7:** Tighten the threaded post completely onto the threaded nipple.

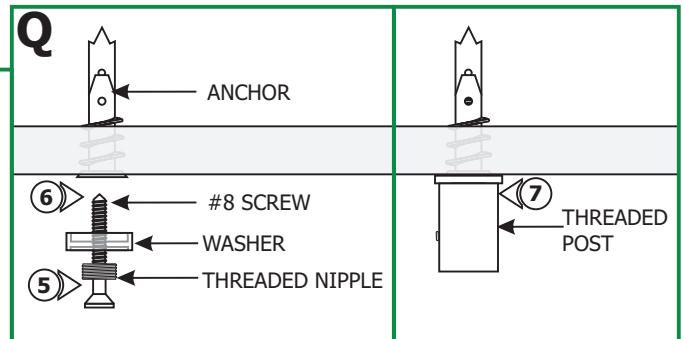

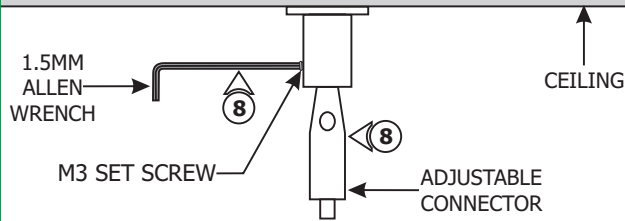
R

8: Insert the adjustable connector completely into the threaded post and tighten the M3 set screw with the 1.5mm Allen wrench.

9: Push the tab on the adjustable connector and feed the aircraft cable through the tab.

10: Pull the aircraft cable coming out of the side of the adjustable connector.

11: When desired height is achieved release the tab to lock the aircraft cable in place.

12: Use fingers to tighten the Fast Jack fixture connector into the Fast Jack canopy.

13: If necessary, repeat steps 9 through 11. Trim off excess aircraft cable coming out of the adjustable connector side hole for a neat finished look.

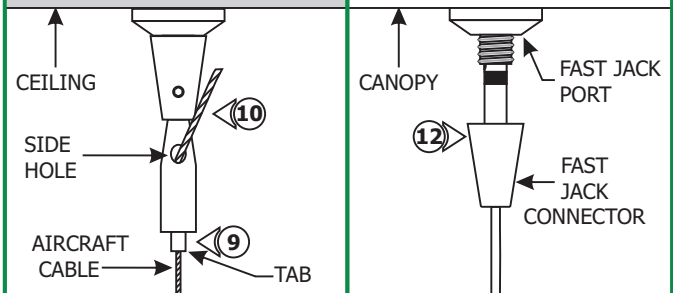
S

Install Cirrus Float to Monorail

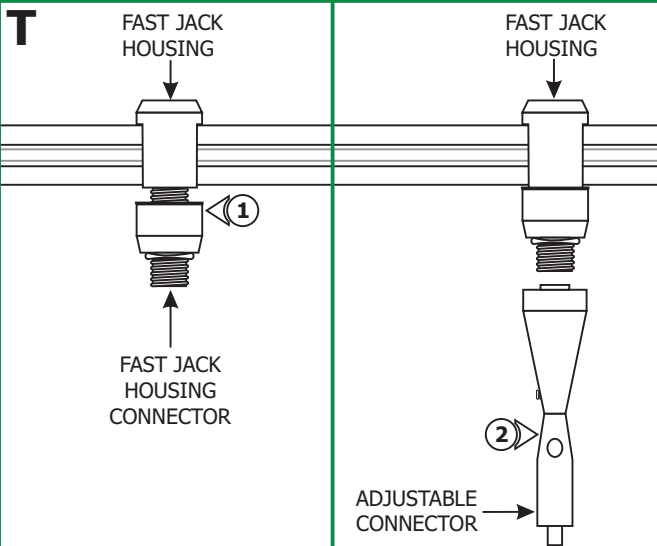
T

NOTE: To install the aircraft cable side of the fixture onto the ceiling, follow steps 3 through 11 and 13 in the "Install Cirrus Float to Single or Multi Port Fast Jack Canopies" starting on page 4.

1: Place the Fast Jack housing onto the Monorail and use fingers to tighten the Fast Jack housing connector to the Fast Jack housing. Make sure the Fast Jack housing connector is not cross-threaded.

2: Place the Fast Jack housing connector of the adjustable connector onto the Monorail and finger-tighten the adjustable connector to the Fast Jack housing. Make sure the Fast Jack housing connector is not cross-threaded.

3: Push the tab on the adjustable connector and feed the aircraft cable through the tab.

4: Pull the aircraft cable coming out of the side of the adjustable connector. Release the tab to lock the aircraft cable in place.

5: Use fingers to tighten the Fast Jack fixture connector into the Fast Jack housing connector making sure that it is not cross-threaded.

6: Readjust the aircraft cable to the desired height using steps 3 and 4. When desired height is achieved, release the tab to lock the aircraft cable in place.

7: Trim off excess aircraft cable coming out of the adjustable connector side hole for a neat finished look.

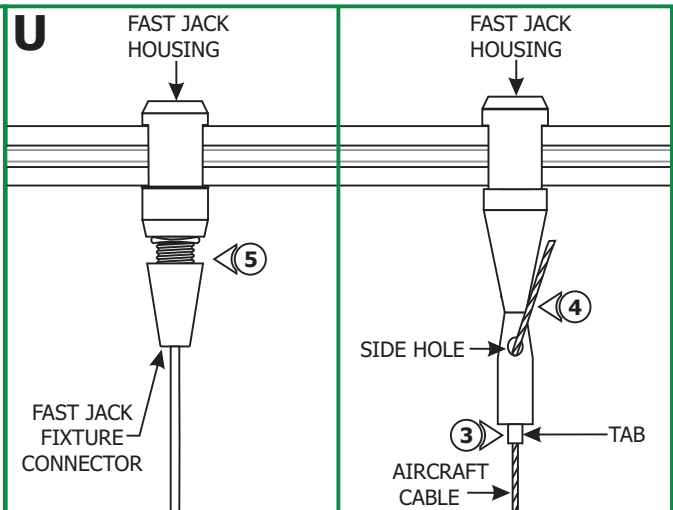
U

Install Cirrus Float to Monorail 2 Circuit

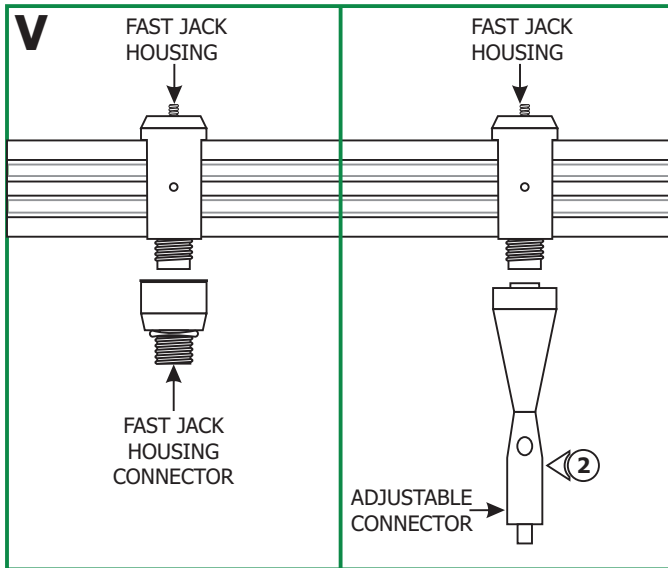

NOTE: To install the aircraft cable side of the fixture onto the ceiling, follow steps 3 through 11 and 13 in the "Install Cirrus Float to Single or Multi Port Fast Jack Canopies" starting on page 4.

- 1: Place the Fast Jack housing onto the Monorail 2 Circuit and use fingers to tighten the Fast Jack housing connector to the Fast Jack housing. Make sure the Fast Jack housing connector is not cross-threaded.
- 2: Place the Fast Jack housing connector of the adjustable connector onto the Monorail 2 Circuit and finger-tighten the adjustable connector to the Fast Jack housing. Make sure the Fast Jack housing connector is not cross-threaded.

- 3: Push the tab on the adjustable connector and feed the aircraft cable through the tab.
- 4: Pull the aircraft cable coming out of the side of the adjustable connector. Release the tab to lock the aircraft cable in place.
- 5: Use fingers to tighten the Fast Jack fixture connector into the Fast Jack housing connector making sure that it is not cross-threaded.
- 6: Readjust the aircraft cable to the desired height using steps 3 and 4. When desired height is achieved, release the tab to lock the aircraft cable in place.
- 7: Trim off excess aircraft cable coming out of the adjustable connector side hole for a neat finished look.

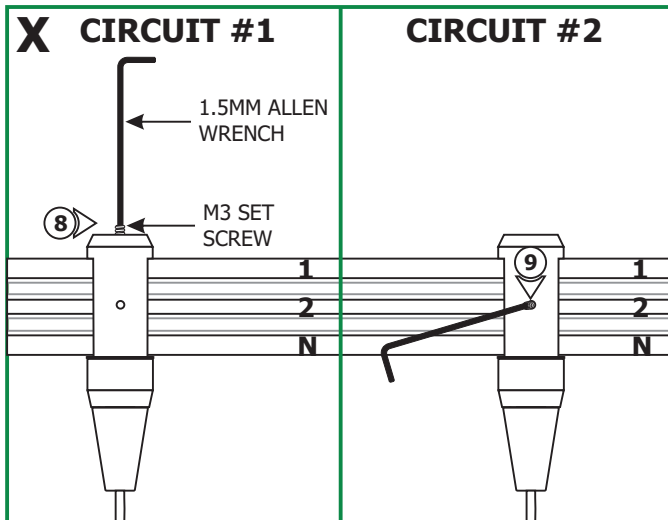
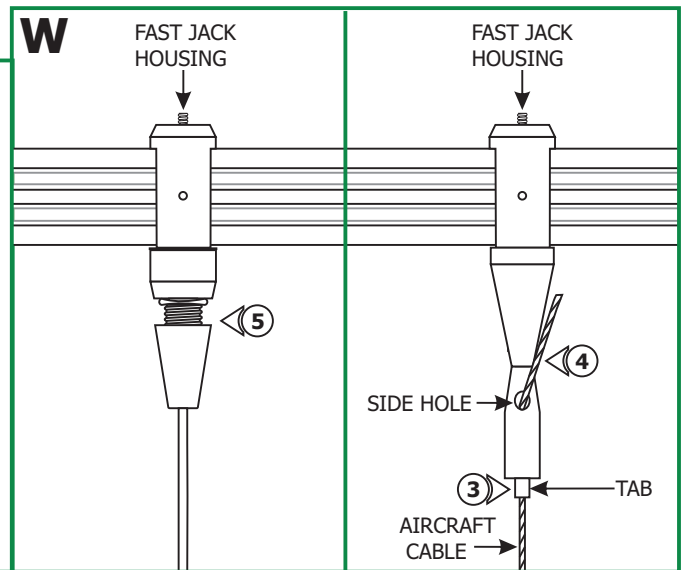

- 8: To power the fixture from circuit #1, top and bottom (neutral) rails, tighten the M3 set screw on top of the housing with the 1.5mm Allen wrench. **Make sure this set screw connection is very tight.**
- 9: To power the fixture from circuit #2, middle and bottom (neutral) rails, remove the M3 set screw from top of the housing and tighten it into the side threaded hole with the 1.5mm Allen wrench. **Make sure this set screw connection is very tight.**

NOTE: To avoid shorting the system, do not use more than one set screw to select a circuit on the Monorail 2 Circuit connector.

NOTE: Do not load either circuit over the maximum system rating.