

## Installation Instructions for Fast Jack Crystal Spirit Pendant

### IMPORTANT SAFETY INSTRUCTIONS

To reduce the risk of fire, electrical shock, exposure to excessive UV radiation, or injury to persons:

- Use this fixture indoors only.
- Do not look directly at the lamp while the fixture is on.
- **RISK OF FIRE:** Use only the type of lamp and maximum wattage indicated in this instruction manual.
- Never cover the halogen lamp with anything other than a lamp shield provided by Edge Lighting and never place flammable material close to the fixture.
- Never turn the fixture on and off by connecting and disconnecting the halogen lamp.
- Do not touch the fixture head, shade or lamp shield while the fixture is on. These surfaces may be **VERY HOT**.
- Do not touch lamp at anytime. Use a soft cloth instead as oil from skin may damage lamp.
- It is normal for a new halogen lamp to produce minor smoke when first turned on.
- Do not operate the luminaire with a missing or damaged shield.
- Turn power off and allow to cool before replacing lamp.

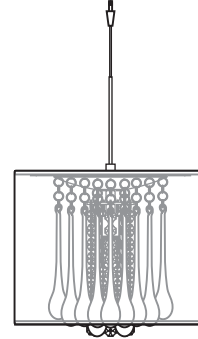

### IMPORTANT INFORMATION

- This product is ETL listed for indoor dry locations and approved to be used at any height above the finished floor.

**SAVE THESE INSTRUCTIONS!**

### Install the Fixture

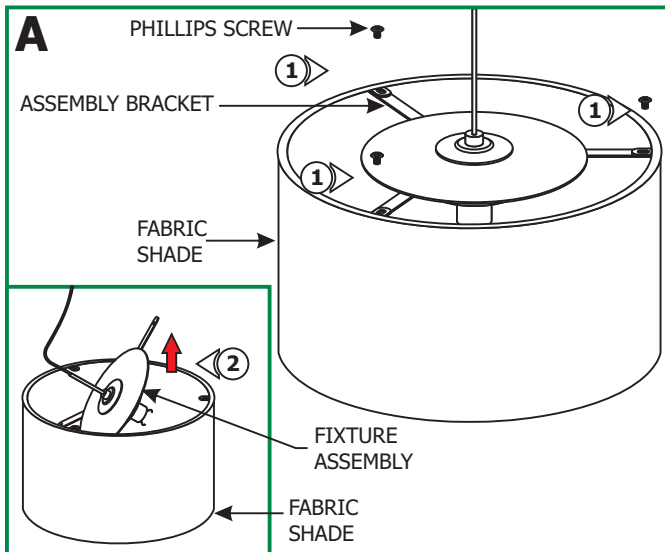

- 1: While holding the fixture, carefully remove the three Phillips screws from the assembly bracket.
- 2: Slightly turn the fixture assembly on its side and pull it out of the fabric shade.

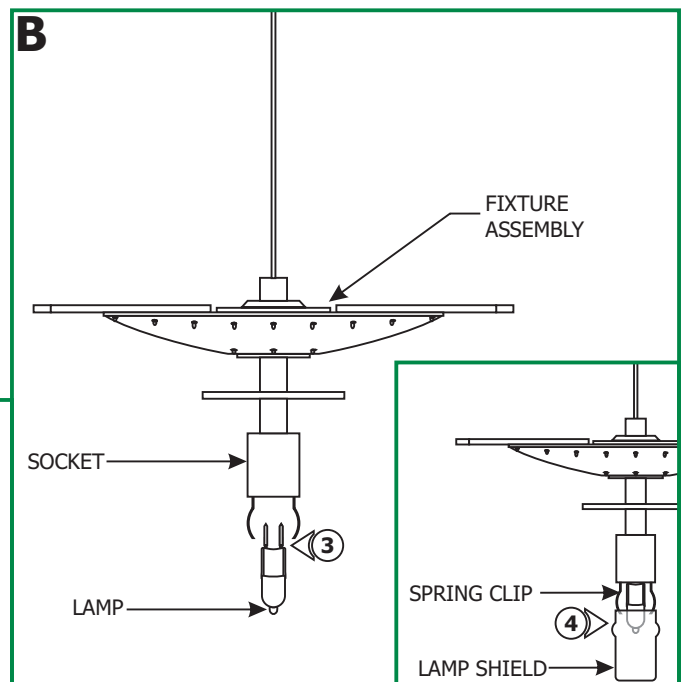

**CAUTION:** To reduce risk of a burn or electrical shock during lamping, disconnect the power to the fixture.

Use **MAX 50** Watt, Type Bi-Pin Halogen Lamp.

- 3: Push the lamp pins completely into the socket holes.
- 4: Push the lamp shield onto the spring clips.

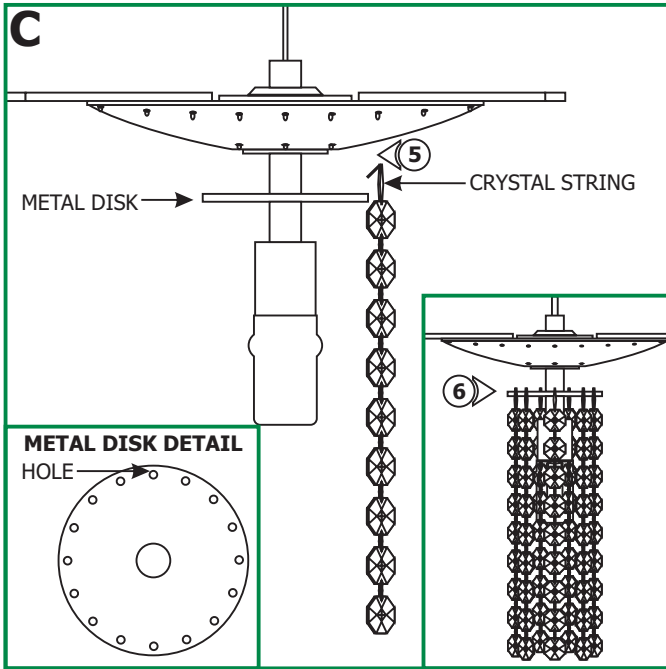

**5:** Take one of the crystal strings and insert the hook into one of the holes on the metal disk.

**6:** Repeat step 5 to install remaining crystal strings.

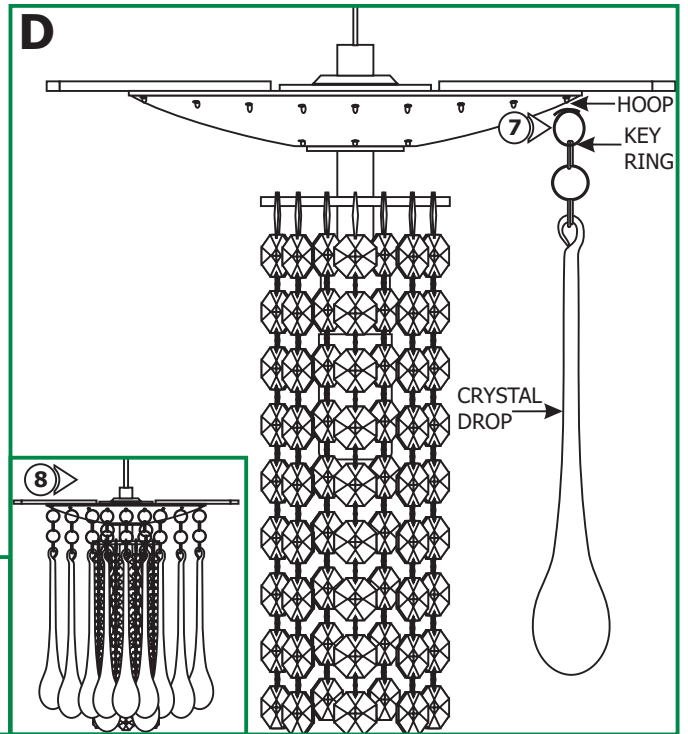

**7:** Install a crystal drop, by squeezing the key ring to open the end. Slide the end through the hoop and rotate it inside the hoop to lock in place.

**8:** Repeat step 7 to install remaining crystals drops.

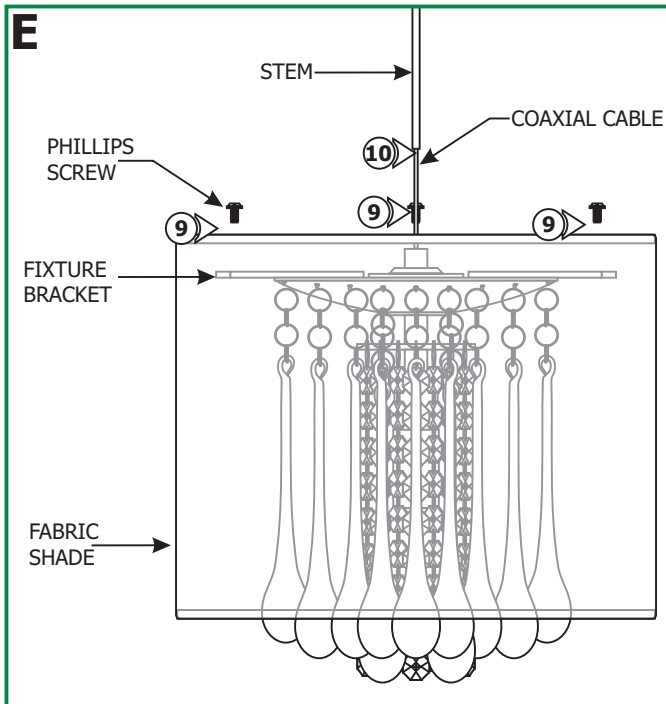

**9:** Feed the coaxial cable through the fabric shade and lower the fabric shade to rest onto the assembly bracket. Secure the shade to the assembly bracket by using the three Phillips screws

**10:** Slide the stem down the coaxial cable adjacent to the fixture assembly.

## Adjust the Fixture Height

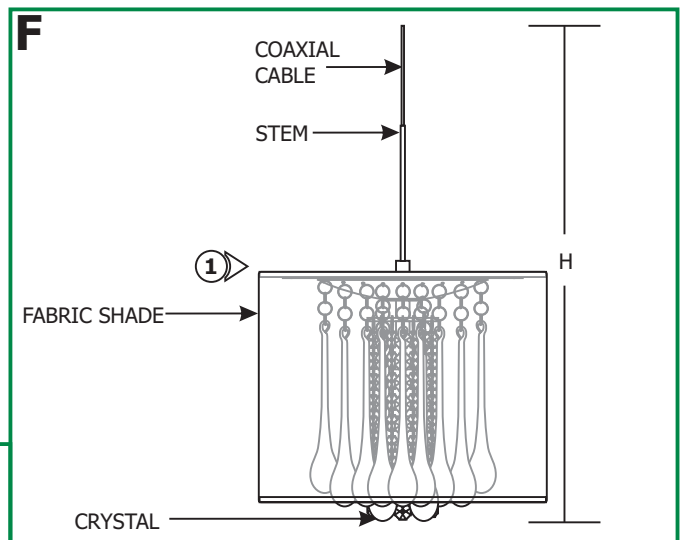

**1:** Cut the coaxial cable to the desired height (H) with a sharp cutter. The overall fixture height is measured from the bottom of the crystals to the end of the coaxial cable.

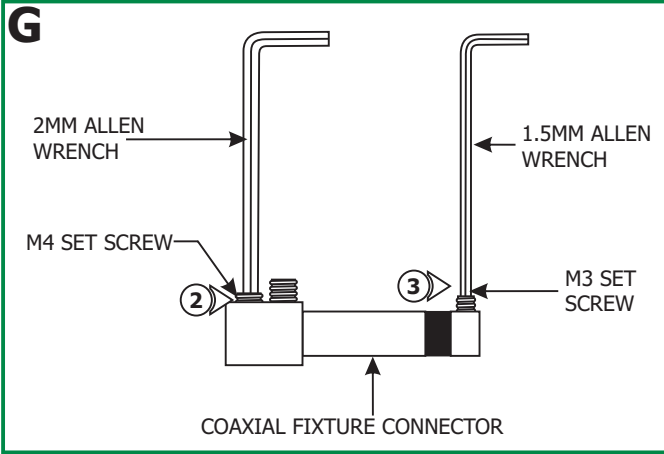

**2:** Loosen the two M4 set screw on base of the coaxial fixture connector with the 2mm Allen wrench provided. **Do not remove these set screw.**

**3:** Remove the M3 set screw on tip of the connector with the 1.5mm Allen wrench provided.

**4:** Feed the coaxial cable through the conical nipple and flared side of the strain relief tube. Slide the conical nipple and strain relief tube down the coaxial cable.

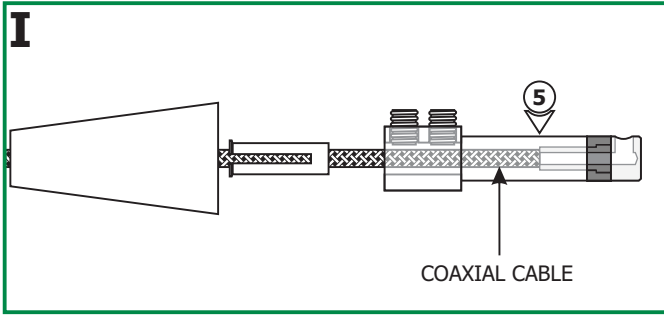
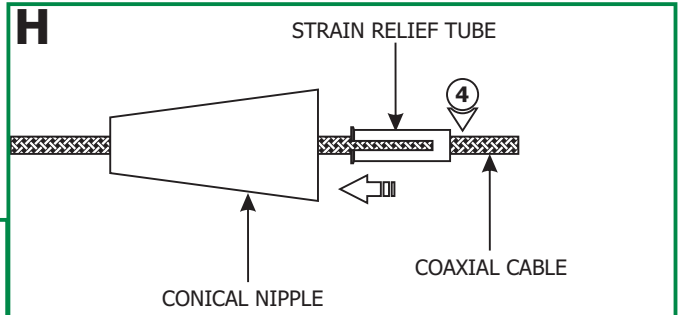

**5:** Feed the coaxial cable into the coaxial fixture connector. The coaxial cable will come to a stop point.

**6:** Keep feeding the coaxial cable in until the inner wire is visible in the screw hole of the fixture connector tip. The outer metal jacket will start to wrinkle.

**7:** Hold the fixture connector in place. Replace and tighten the M3 set screw on fixture connector tip with the 1.5mm Allen wrench.

**8:** Pull down the outer metal jacket to smooth the wrinkles.

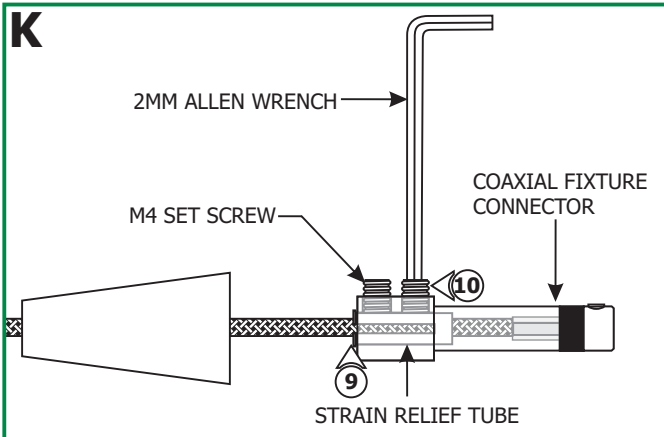
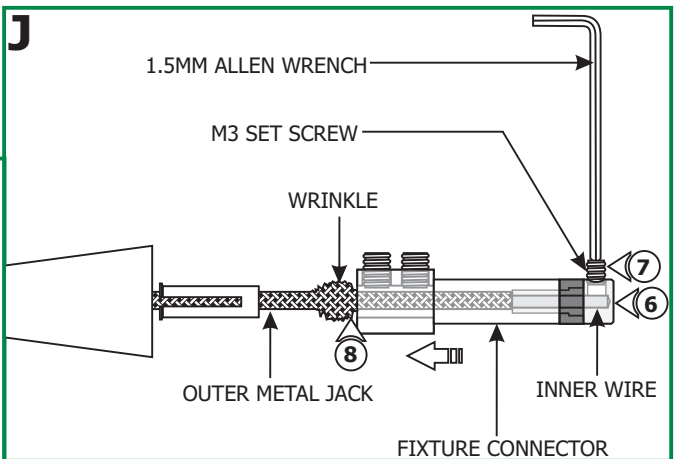

**9:** Push the strain relief tube completely into the coaxial fixture connector. Make sure the slot on the strain relief tube is not inline with the M4 set screw.

**10:** Tighten the two M4 set screws with the 2mm Allen wrench.

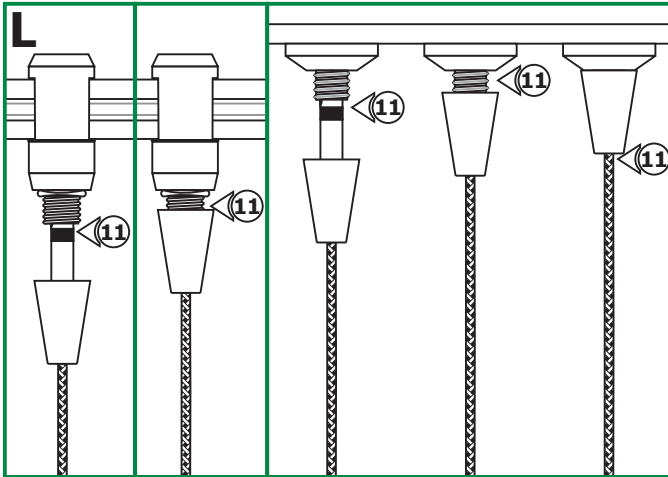

**11:** Use fingers to tighten the Fast Jack fixture connector into the Fast Jack system connector (Monorail, Monorail Wall, Monorail 2 Circuit, or multi-port and mono-point canopies. Refer to the instructions provided with the system connector or canopy).

**12:** Refer to the instructions provided with the Monorail 2 Circuit fixture connector to choose the Circuit #1 or Circuit #2.

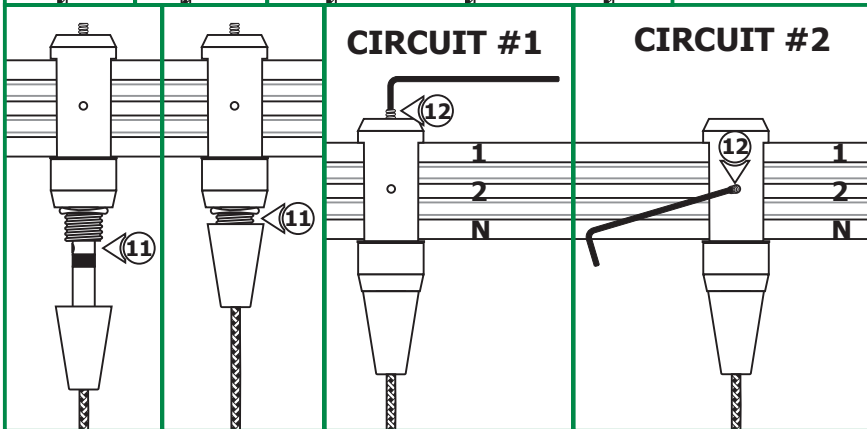

## Replacing the Lamp

**CAUTION:** To reduce risk of a burn or electrical shock during lamping, disconnect the power to the fixture.

- 1:** Reach the lamp shield through the hanging crystals and remove it.
- 2:** Remove the old lamp.
- 3:** Follow steps 3 & 4 in "Install the Fixture" to install the new lamp.

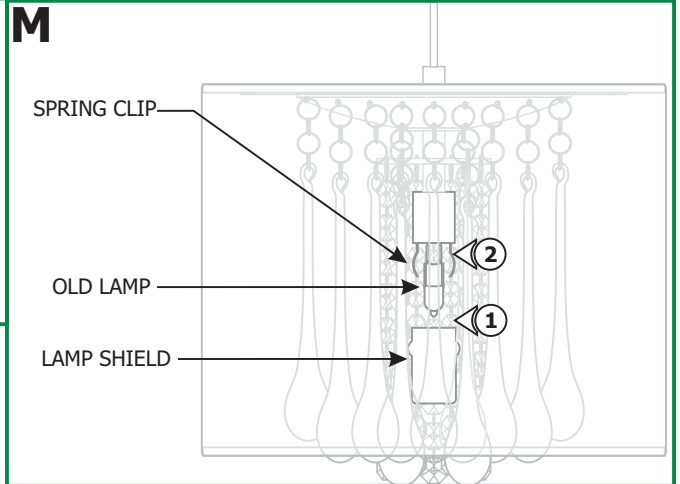

## Balancing the Fixture (Optional)

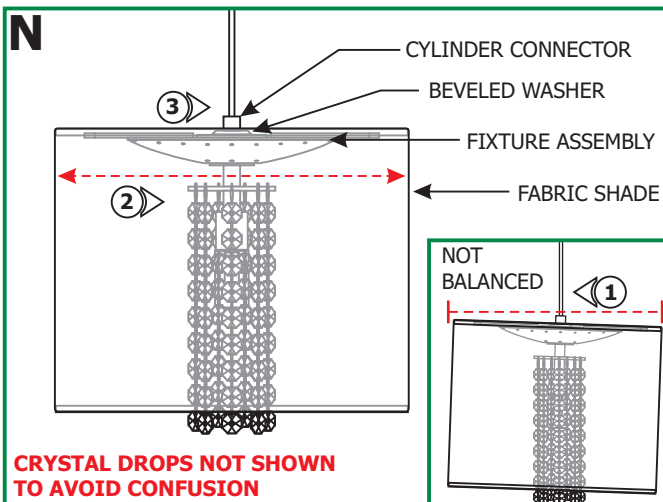

**CRYSTAL DROPS NOT SHOWN TO AVOID CONFUSION**

**NOTE:** In some cases fixture may be slightly off balanced, follow steps 1 through 3 to adjust the fixture.

- 1:** Carefully loosen cylinder connector and the beveled washer (do not remove) about one thread.
- 2:** Slide the fixture assembly towards the direction of the sagging.
- 3:** Once the fixture is balanced tighten the beveled washer and cylinder connector to secure fixture in place.