

Installation Instructions for Fast Jack Scope LED Pendant

IMPORTANT INFORMATION

- This product is ETL listed for indoor dry locations.
- The product is intended to be used with Edge Lighting Monorail systems only.
- The product is safe to be used in food processing or consuming areas without the glass lens. It is safe to use the thermoplastic lens in the fixture. For more information see "Adjusting the Light Beam" section.

SAVE THESE INSTRUCTIONS!



Adjust the Fixture Height

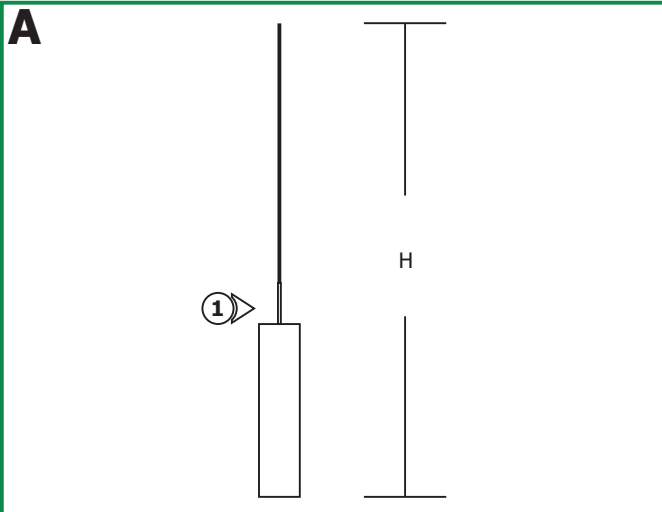

- 1:** Cut the coaxial cable to the desired height (H) with a sharp cutter. The overall fixture height is measured from the bottom of the metal shade to the end of the coaxial cable.

- 2:** Loosen the M4 set screw on base of the coaxial fixture connector with the 2mm Allen wrench provided. **Do not remove this set screw.**
- 3:** Remove the M3 set screw on tip of the connector with the 1.5mm Allen wrench provided.

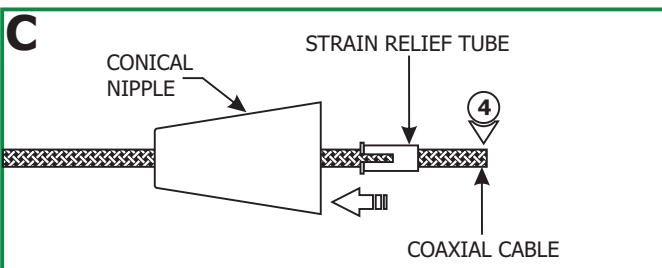
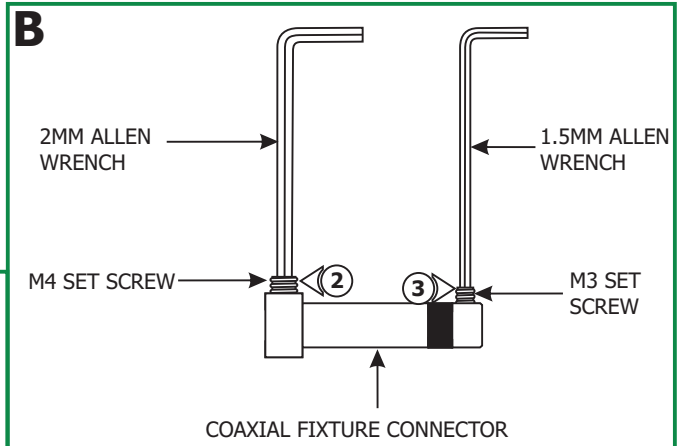

- 4:** Feed the coaxial cable through the conical nipple and flared side of the strain relief tube. Slide the conical nipple and strain relief tube down the coaxial cable.

- 5:** Feed the coaxial cable into the coaxial fixture connector. The coaxial cable will come to a stop point.

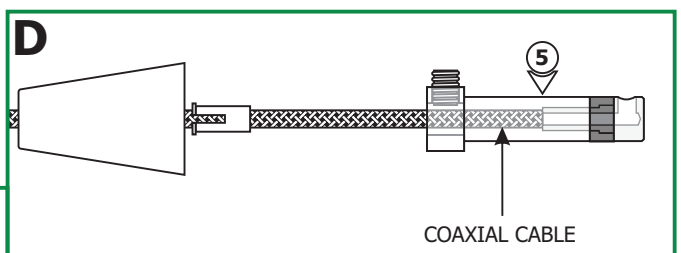

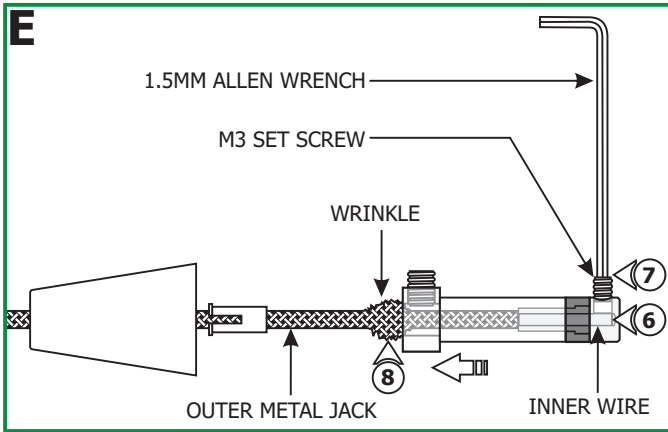

- 6:** Keep feeding the coaxial cable in until the inner wire is visible in the screw hole of the fixture connector tip. The outer metal jacket will start to wrinkle.
- 7:** Hold the fixture connector in place. Replace and tighten the M3 set screw on fixture connector tip with the 1.5mm Allen wrench.
- 8:** Pull down the outer metal jacket to smooth the wrinkles.

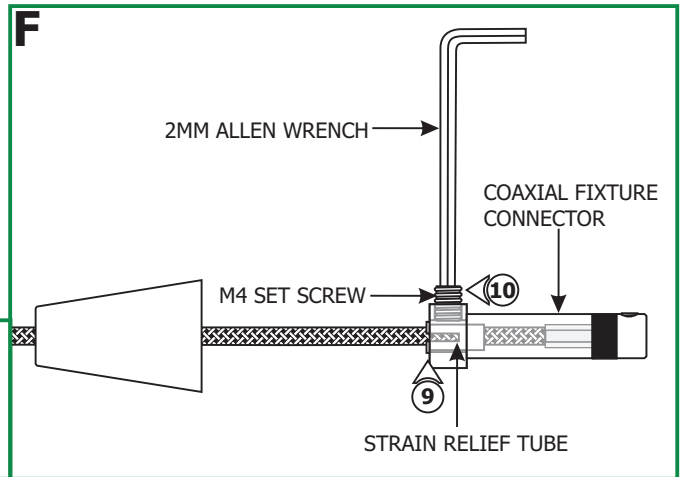

- 9:** Push the strain relief tube completely into the coaxial fixture connector. Make sure the slot on the strain relief tube is not inline with the M4 set screw.
- 10:** Tighten the M4 set screw with the 2mm Allen wrench.

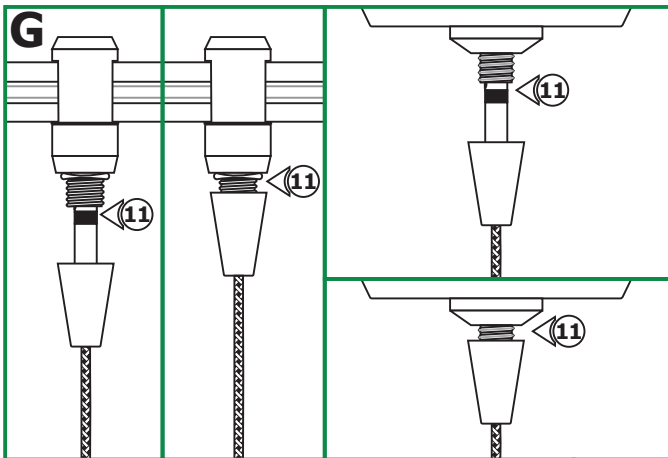

- 11:** Use fingers to tighten the Fast Jack fixture connector into the Fast Jack system connector (Monorail, Monorail 2 Circuit, or canopy connector - Refer to the instructions provided with the system connector or canopy).
- 12:** Refer to the instructions provided with the Monorail 2 Circuit fixture connector to choose Circuit #1 or Circuit #2.

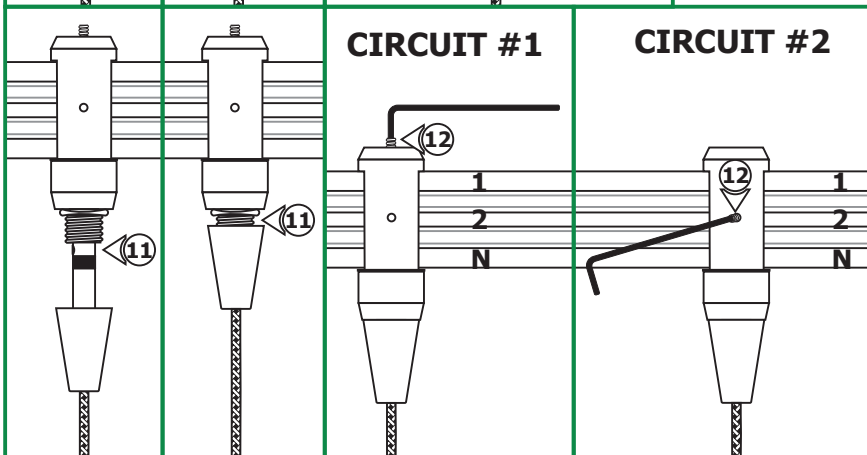

Adjusting the Light Beam & Intensity

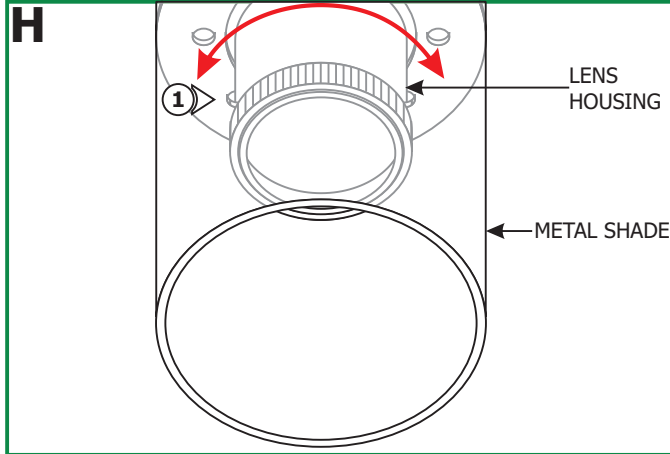

1: Rotate the lens housing (inside the fixture body) and set the beam spread to either spot or flood.

NOTE: The Scope LED head consumes **10** watts and contains integrated LED lamps which are rated for 50,000 hours.

NOTE: For 15% to 20% more light output, the soft focus film can be removed, however the corners of the beam will have sharp edge. Omit these steps if not adjusting the light output.

2: Use a small Allen wrench or a pen point to loosen the lens housing ring.

3: Remove the lens housing ring, the soft focus film and the PMMA lens. Please save these items for future use.

NOTE: To reinstall the soft focus film, place the PMMA lens followed by the soft focus film and the lens housing ring. Tighten the ring with the small Allen wrench or pen point to hold the assembly in place.

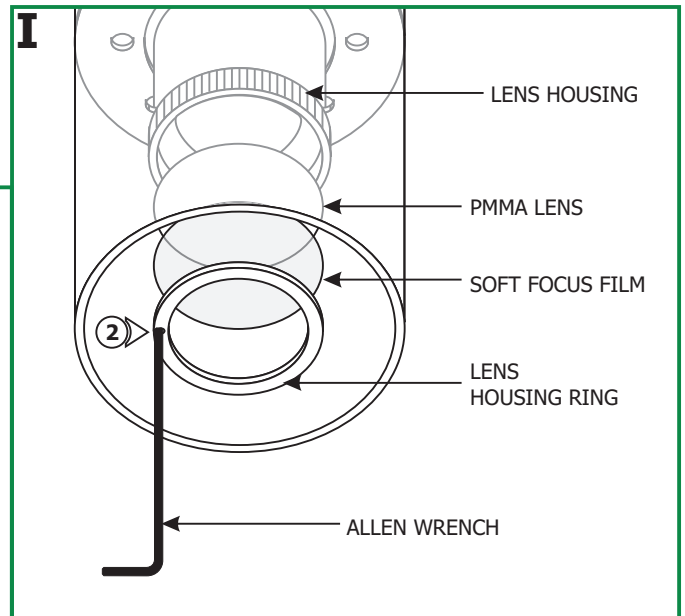

Install the Crystal Accessory

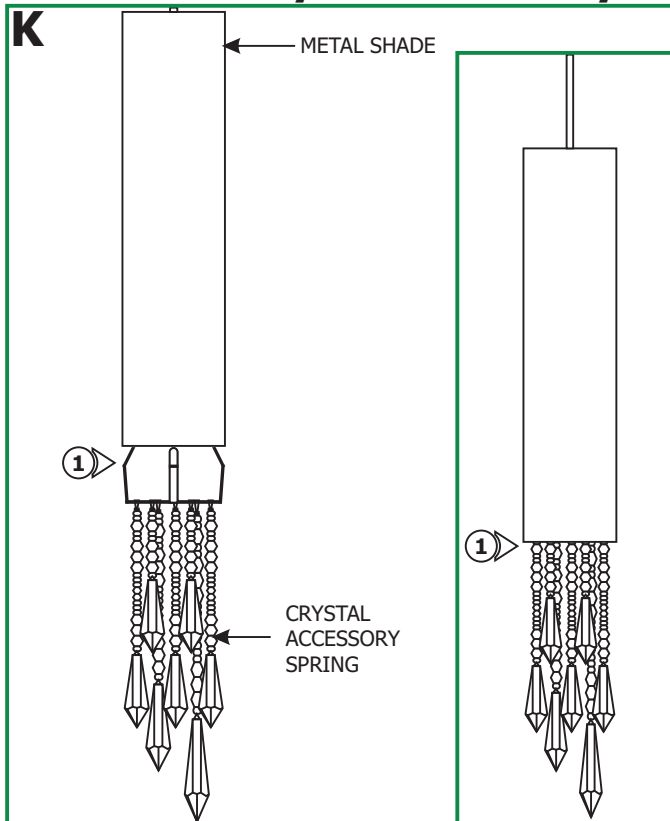

NOTE: Make all necessary adjustment to fixture, before crystal accessory (sold separately) is installed.

1: Squeeze the crystal accessory spring ends and carefully push it into the metal shade.