

## Installation Instructions for 2" Square Fast Jack LED Power Canopy

### IMPORTANT INFORMATION

- This product is ETL listed for indoor dry locations.
- This product installs to Edge Lighting 2" electrical box only.
- Minimum electrical box volume must be 6 cubic inches (98 cubic centimeters).
- For dimming information visit [www.edgelighting.com](http://www.edgelighting.com).
- This product can be used with LED or halogen Fast Jack fixtures.

**SAVE THESE INSTRUCTIONS!**

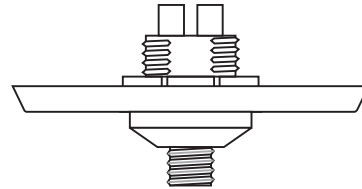

### Install the Canopy

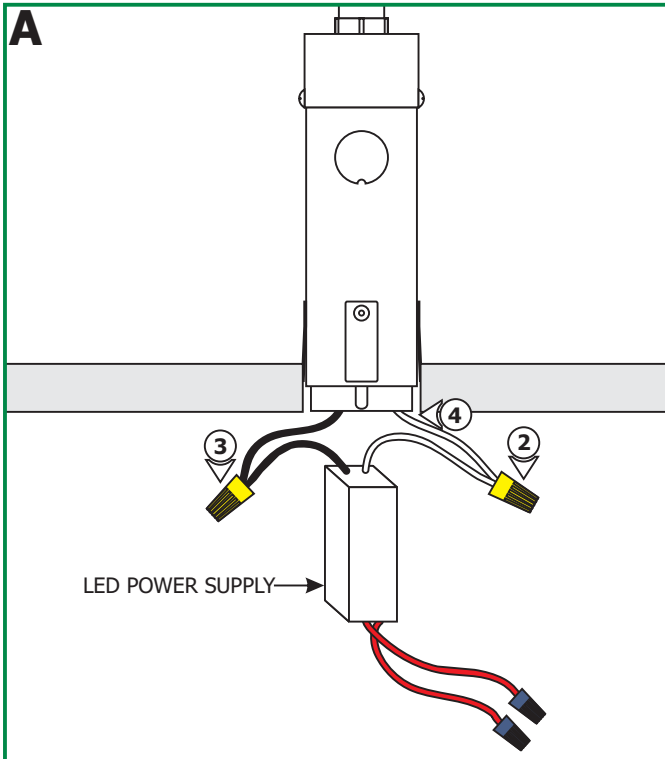

**NOTE:** Install the 2" electrical box before proceeding with the steps below. Refer to the instructions provided with the box.

- 1:** Turn the power to electrical box off.
- 2:** Connect the white LED power supply wire to the neutral power wire with a wire nut.
- 3:** Connect the black LED power supply wire to the hot power wire with a wire nut.
- 4:** Place the LED power supply and wires inside the 2" electrical box.

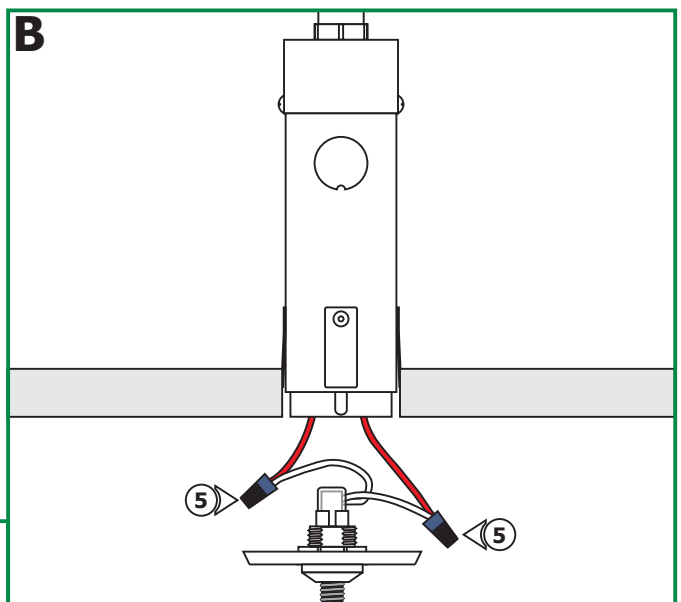

- 5:** Connect each Fast Jack canopy wire to one low voltage LED power supply with a wire nut.

**C**

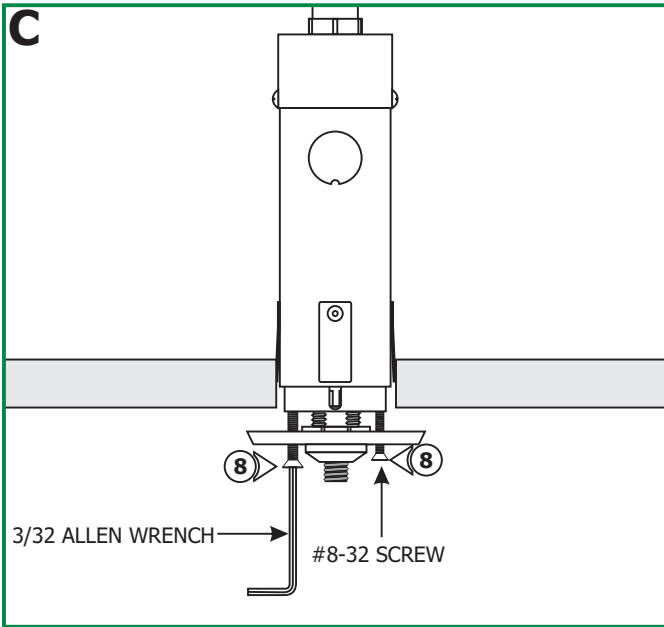

**7:** Place all wires inside the 2" electrical box.

**8:** Secure the Fast Jack canopy to the 2" electrical box by tightening the two provided #8-32 screws with the 3/32 Allen wrench.

**D**

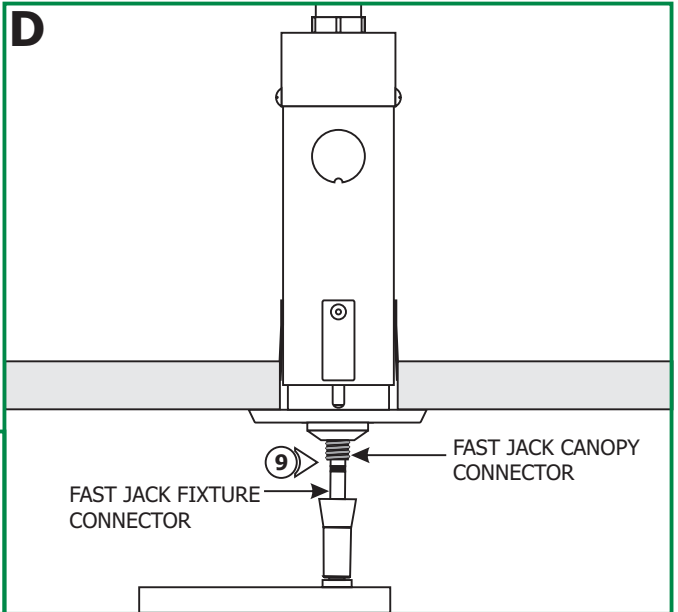

**CAUTION: Risk of Fire: MAX** load of Fast Jack LED canopy is 60 watt.

**9:** Use fingers to tighten the Fast Jack fixture connector into the Fast Jack canopy connector.