

Installation Instructions for 4" Round & Square Fast Jack LED Power Canopies

IMPORTANT INFORMATION

- This product is ETL listed for indoor dry locations.
- This product can be installed to a 4" electrical box with round plaster ring, or to an octagon electrical box.
- Minimum electrical box volume must be 6 cubic inches (98 cubic centimeters).
- For dimming information visit www.edgelighting.com.
- This product can be used with LED or halogen Fast Jack fixtures.

SAVE THESE INSTRUCTIONS!

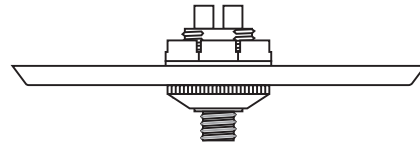

Install the Canopy

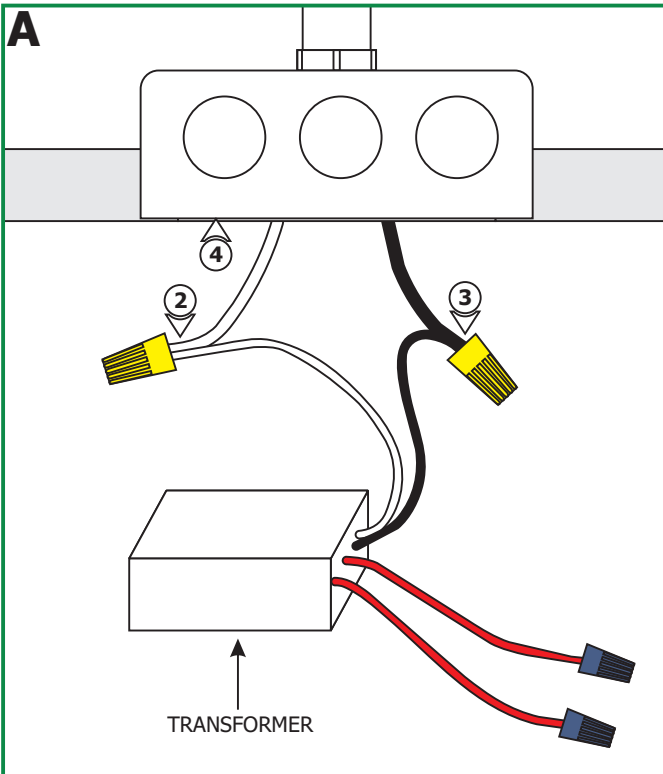

1: Turn the power to electrical box off.

2: Connect the white transformer wire to the neutral power wire with a wire nut.

3: Connect the black transformer wire to the hot power wire with a wire nut.

4: Place the transformer and transformer wires inside the electrical box.

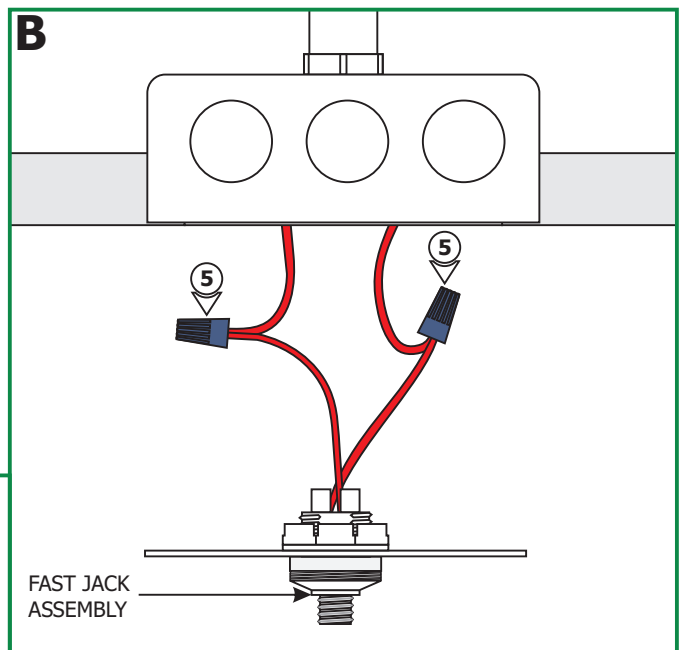

NOTE: Use the universal round crossbar (provided) if the electrical box holes are not spaced 2-3/4" apart.

5: Connect each Fast Jack assembly wire to one low voltage transformer wire with a wire nut.

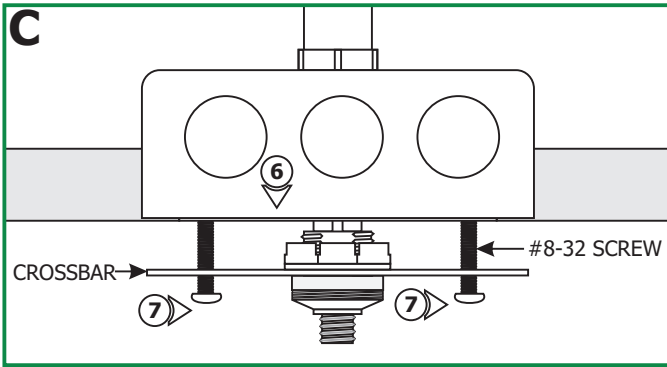

- 6:** Place all wires inside the electrical box.
- 7:** Secure the Fast Jack assembly crossbar to the electrical box by tightening the two provided #8-32 screws.

8: Place the canopy center hole onto the Fast Jack port against the electrical box and secure it in place by tightening the knurled cap to the Fast Jack port. **Make sure the knurled cap is not cross threaded.**

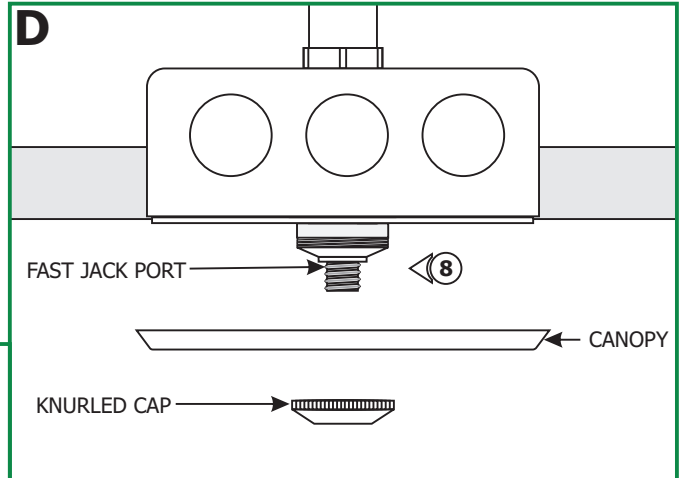

CAUTION: Risk of Fire: MAX load of Fast Jack LED canopy is **60** watt.

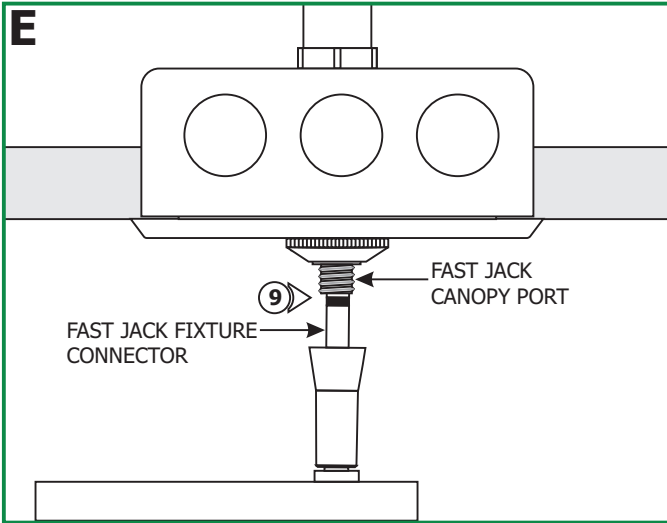

- 9:** Use fingers to tighten the Fast Jack fixture connector into the Fast Jack canopy port.