

Installation Instructions for Fast Jack Power Round & Square 4" Flat Canopies

IMPORTANT INFORMATION

- This product is ETL listed for indoor dry locations.
- This product is dimmable with a standard incandescent dimmer.
- This product can be installed to a 4" electrical box with round plaster ring, or to an octagon electrical box.
- Minimum electrical box volume must be 6 cubic inches (98 cubic centimeters).

SAVE THESE INSTRUCTIONS!

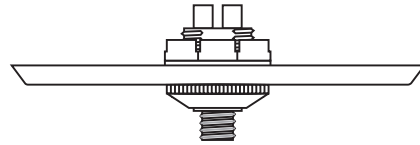

Install the Canopy

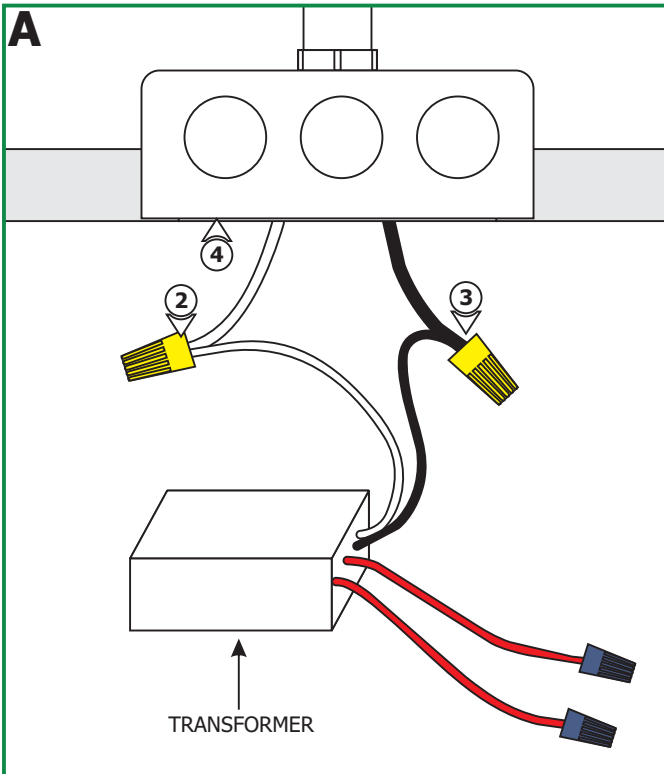

- 1: Turn the power to electrical box off.
- 2: Connect the white transformer wire to the neutral power wire with a wire nut.
- 3: Connect the black transformer wire to the hot power wire with a wire nut.
- 4: Place the transformer and transformer wires inside the electrical box.

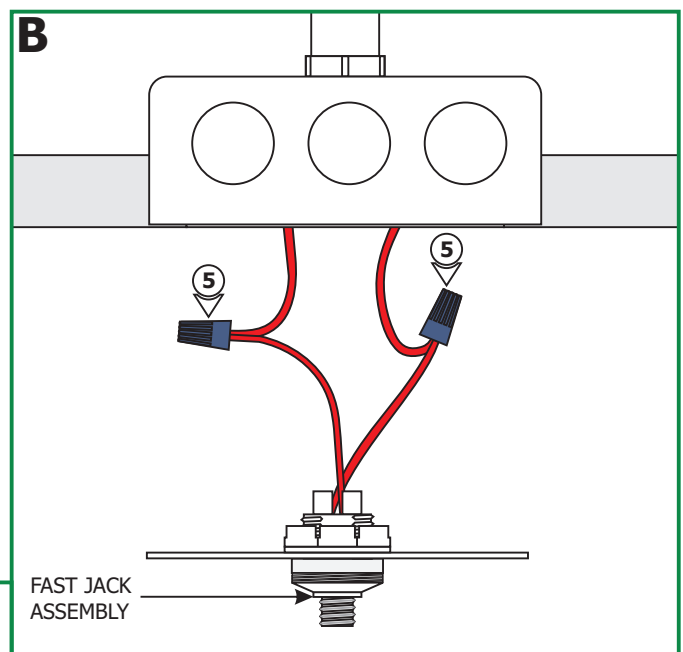

- 5: Connect each Fast Jack assembly wire to one low voltage transformer wire with a wire nut.

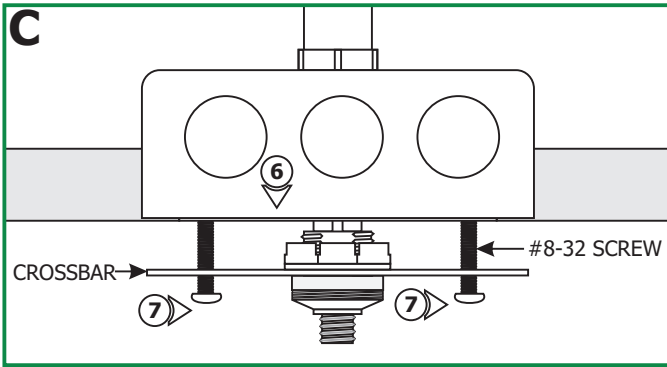

- 6:** Place all wires inside the electrical box.
- 7:** Secure the Fast Jack assembly crossbar to the electrical box by tightening the two provided #8-32 screws.

8: Place the canopy center hole onto the Fast Jack port against the electrical box and secure it in place by tightening the knurled cap to the Fast Jack port. **Make sure the knurled cap is not cross threaded.**

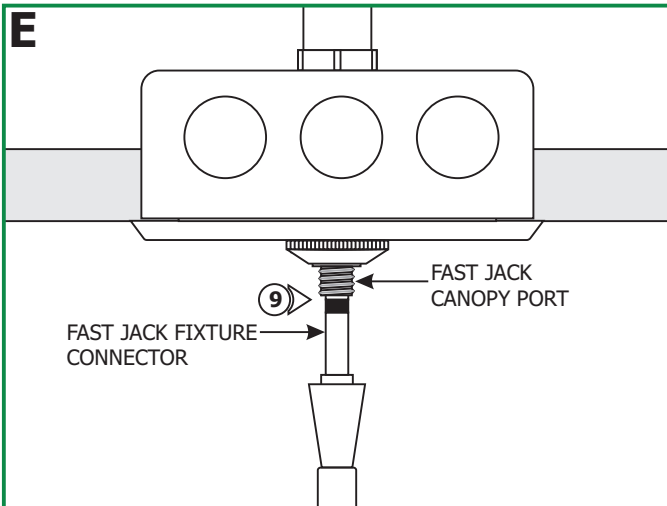
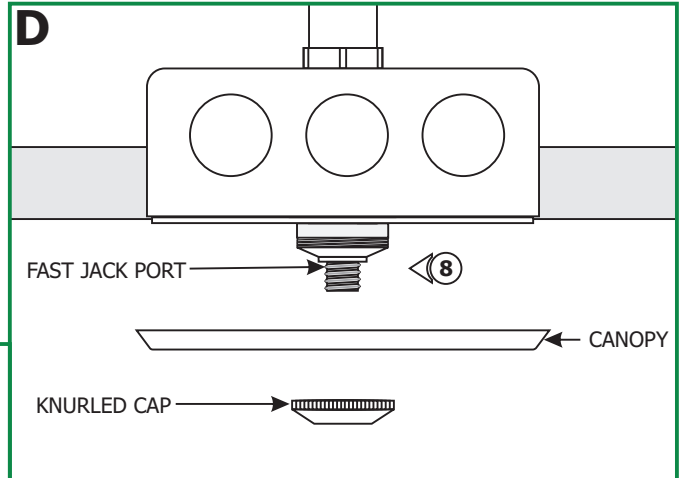

CAUTION: Risk of Fire: MAX load of Fast Jack canopy is **75** watt.

- 9:** Use fingers to tighten the Fast Jack fixture connector into the Fast Jack canopy port.