

Installation Instructions for Galleria Picture Light

IMPORTANT SAFETY INSTRUCTIONS

To reduce the risk of fire, electrical shock, exposure to excessive UV radiation, or injury to persons:

- Do not look directly at the lamp while the fixture is on.
- **RISK OF FIRE:** Use only the type of lamp and maximum wattage indicated in this instruction manual.
- Never cover the halogen lamp with anything other than a lamp shield provided by Edge Lighting and never place flammable material close to the fixture.
- Never turn the fixture on and off by connecting and disconnecting the halogen lamp.
- Do not touch the fixture head, shade or lamp shield while the fixture is on. These surfaces may be **VERY HOT**.
- Do not touch lamp at anytime. Use a soft cloth instead as oil from skin may damage lamp.
- It is normal for a new halogen lamp to produce minor smoke when first turned on.
- Do not operate the luminaire with a missing or damaged shield.
- Turn power off and allow to cool before replacing lamp.

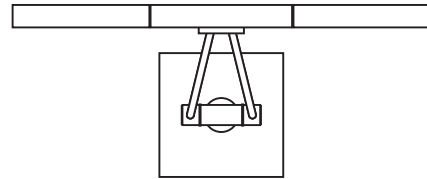

IMPORTANT INFORMATION

- This product is wall mount for indoor locations.
- This product can mount to either a 4" square electrical box with round plaster ring or an octagon electrical box.
- This product can be dimmed with a low voltage electronic dimmer.

SAVE THESE INSTRUCTIONS!

Install the Fixture

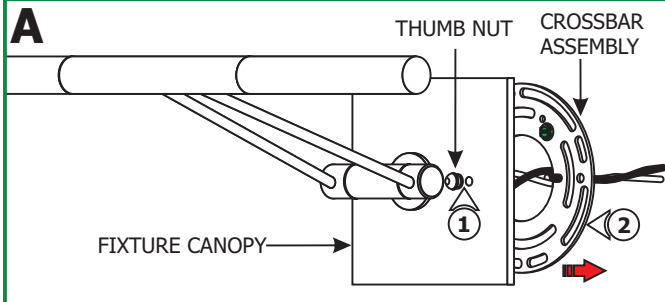

1: Loosen and remove the two thumb nuts from the front of the fixture canopy.

2: Pull the crossbar assembly off of the fixture canopy.

- 3:** Connect the white transformer wire to the neutral power wire with a wire nut.
- 4:** Connect the black transformer wire to the hot power wire with a wire nut.
- 5:** Place the transformer and transformer wires inside the electrical box.

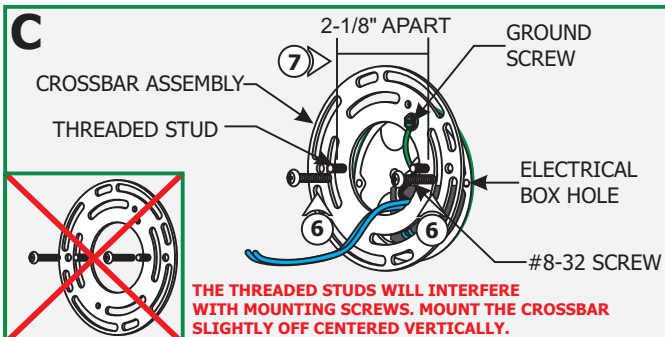
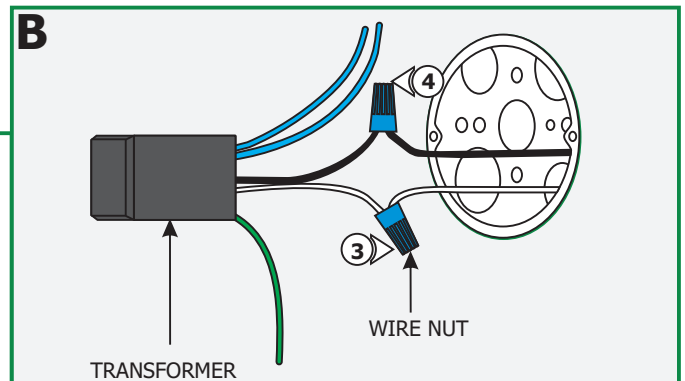

6: Mount the crossbar assembly to the electrical box holes with the provided #8-32 screws so that the two inner threaded studs (spaced 2-1/8" apart) on crossbar are leveled horizontally. **Make sure to mount the #8-32 screws just below the threaded studs for proper spacing.**

7: Connect the transformer green wire to the crossbar assembly ground screw. Make sure that the crossbar assembly is grounded in accordance with local electrical codes.

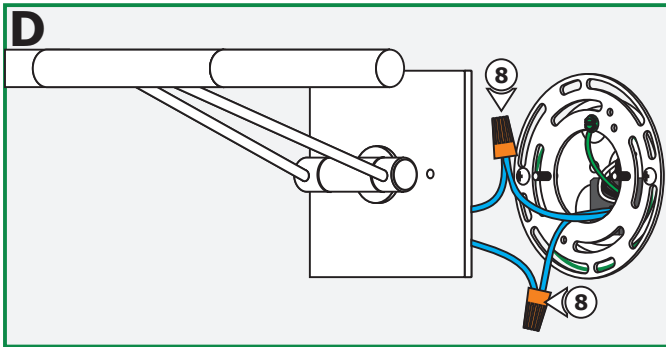

8: Connect each transformer low voltage (blue wire) to one fixture wire with a wire nut.

9: Place all wires and wire connections inside the electrical box.

10: Align and slide the canopy assembly holes onto the threaded studs. While holding the fixture, tighten the two thumb nuts to secure the canopy in place. Make sure to mount with the M4 set screws on the fixture arms facing up.

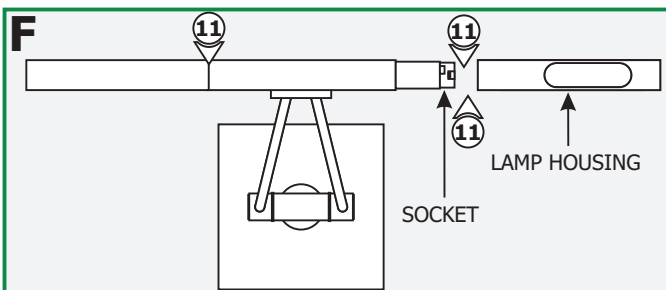
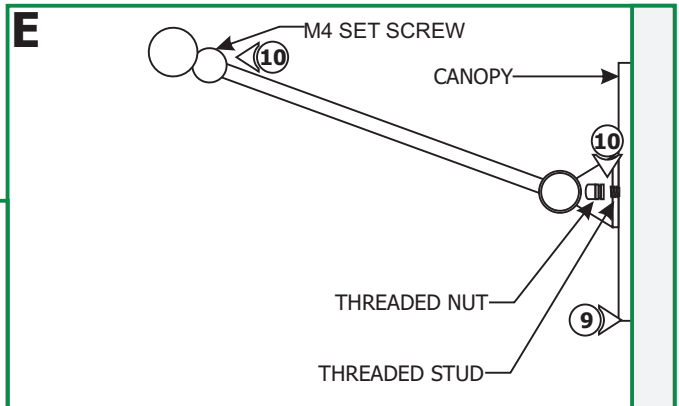

11: Pull out the two lamp housings from the fixture to expose the two sockets.

CAUTION: To reduce risk of a burn or electrical shock during lamping, disconnect the power to the fixture.

NOTE: Use only fingers and a soft cloth to install the lamps.

Use only **MAX 20** Watt Bi-Pin Xenon (Xelogen) lamp, or low pressure halogen lamp specified by the lamp manufacturer to be used with unshielded (without the lamp shield) fixture, for each socket.



12: Push the lamp pins completely into the socket holes.

13: Replace the lamp housings and rotate the fixture arms to a desired position.

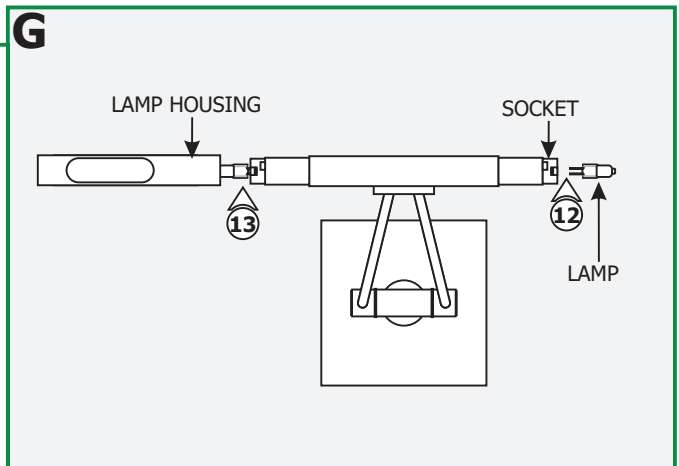

Adjusting the Fixture Arm (Optional)

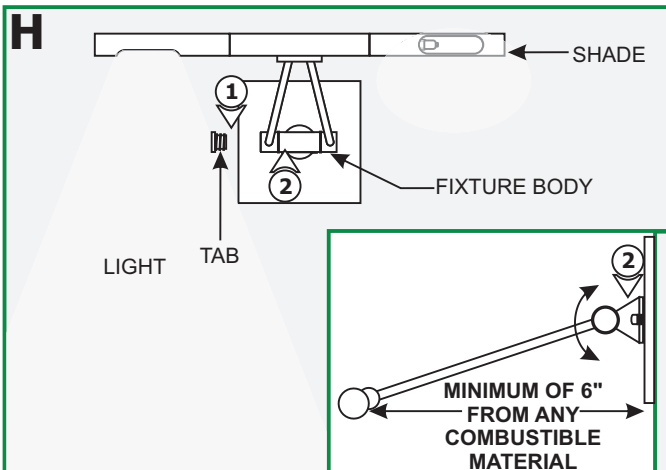

NOTE: In case the fixture arms become loose proceed with the following steps.

1: Remove the tab on the fixture body.

2: Tighten the Phillips screws inside the fixture body.

3: Replace the tab on the fixture body.