

Installation Instructions for Angle and Kurve Display Sign w/4SQ Canopy

IMPORTANT INFORMATION

- This instruction shows a typical installation.
- This product is powered with a 24 volt DC power supply such as PSB-96W-010-24VDC.

SAVE THESE INSTRUCTIONS!

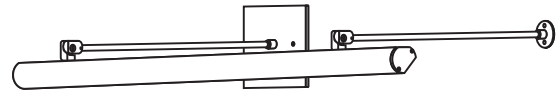

Installation Setup

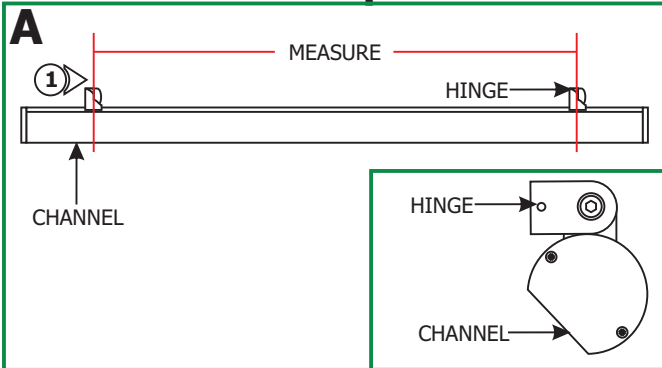

NOTE: Depending on fixture length, the fixture is provided with 2 to 4 hinges.

- 1:** Measure the distance from center of each hinge to the other hinge. Typically, the most left hinge contains the power wires.

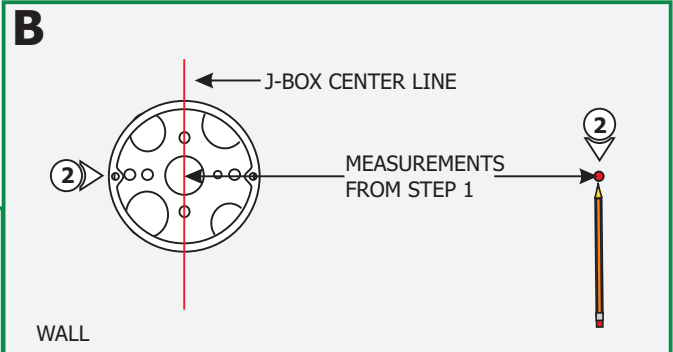

- 2:** The hinge containing power wires should be aligned with the center of the junction box. Starting from the center of the electrical box, mark all measured point(s) onto the wall ensuring the marked points are leveled horizontally with the center of the junction box.

Install Fixture

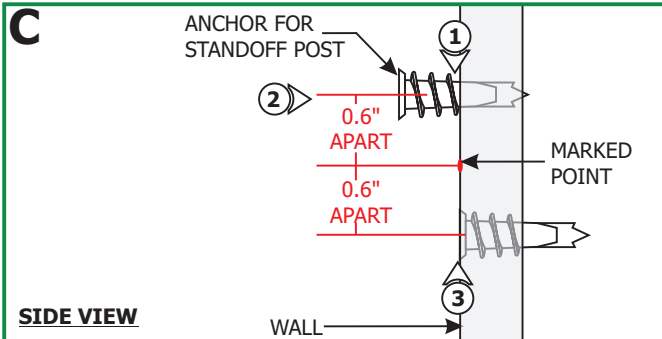

NOTE: The base holes should be in a vertical position at 90° angle to the direction of the fixture.

- 1:** For each base, mark additional points at 0.6" to the top and bottom of the previously marked points.
- 2:** Tap the anchors to the new marked holes with a hammer up to the threaded portion
- 3:** Screw in the threaded portion of the anchor(s) with a Phillips screwdriver.

- 4:** Mount each base to the anchors with two provided #8 screws.

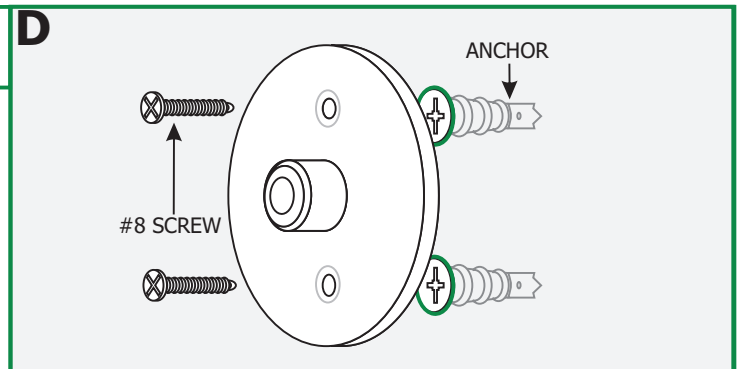

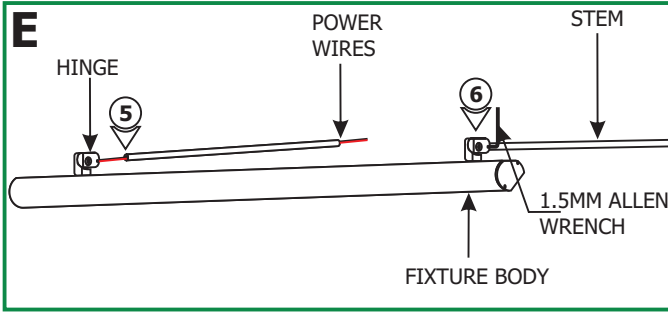

5: Carefully feed the fixture wires from the threaded side of the stem into the stem and completely tighten the stem to the hinge. Tighten the M3 screw on the hinge with 1.5 mm Allen wrench.

6: Tighten the remaining stems to all other hinges.

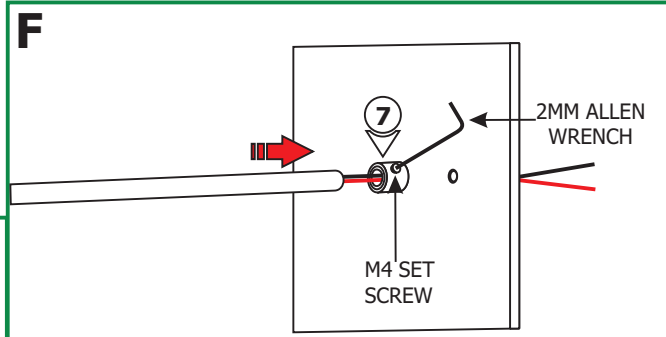

7: Feed the power wires coming out of the stem through the square canopy. Slide the canopy bushing completely onto the stem and secure it in place by tightening the M4 set screw with the provided 2mm Allen wrench.

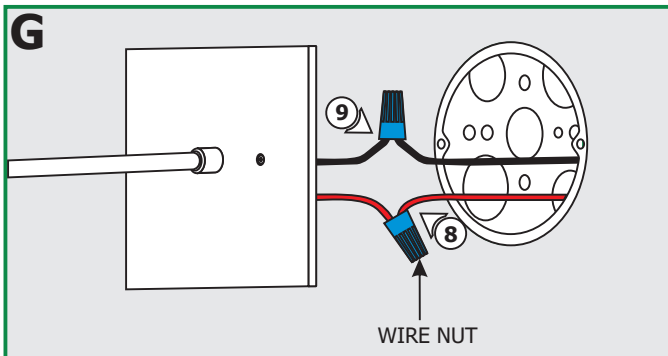

NOTE: The 24 VDC power wires must be present to the junction box. Refer to the installation instructions provided with power supply.

NOTE: It is recommended another person hold the fixture while the electrician connects the power to the fixture.

8: Connect the red fixture wire to the +24VDC power supply wire with a wire nut.

9: Connect the black fixture wire to the -24VDC power supply wire with a wire nut.

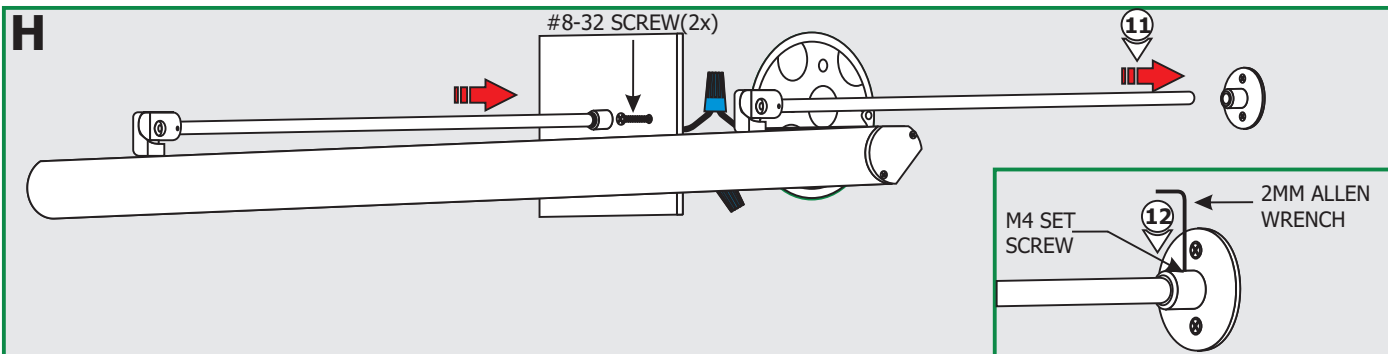

10: Place all wires and wire nut connections into the junction box and simultaneously align and insert the stem(s) completely into the base(s).

11: Align the 4" square canopy holes with the junction box holes and secure the canopy in place by tightening the two provided #8-32 screws through the canopy holes into the junction box holes.

12: Secure the remaining stem(s) to the base(s) by tightening the M4 set screw on the base with the 2MM Allen wrench.

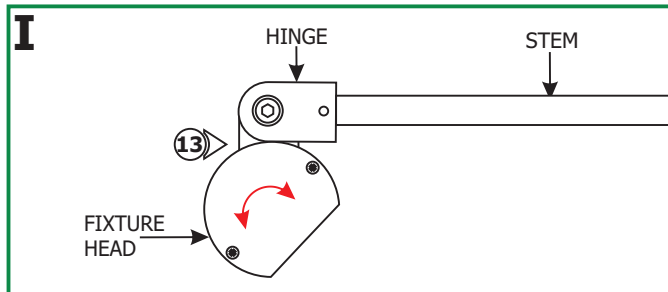

13: Rotate the fixture head to desired angle.