

Installation Instructions for **Angle and Kurve Display Sign w/Feed Through-Power**

IMPORTANT INFORMATION

- This instruction shows a typical installation.

SAVE THESE INSTRUCTIONS!

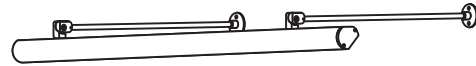

Install the Fixture

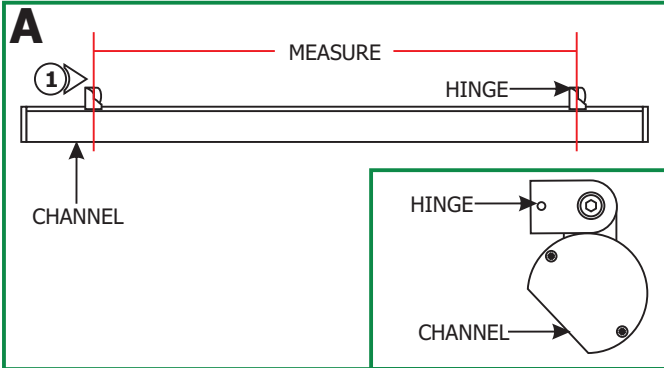

NOTE: Depending on fixture length, the fixture is provided with 2 to 4 hinges.

1: Measure the distance from center of each hinge to the other hinge. Typically, the furthest left hinge contains the power wires.



2: Mark the measured points on the wall where the fixture is to be mounted.

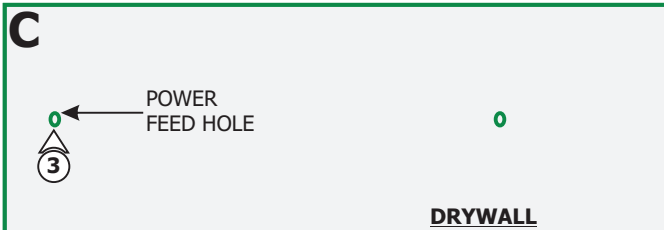

3: Using a 7/16" bit, drill out the left marked hole through the front & back drywall surfaces.

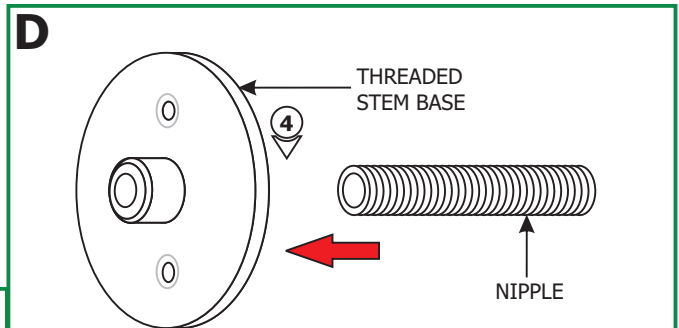

4: Insert and tighten the nipple into the back of the stem base with threads, for the power feed.

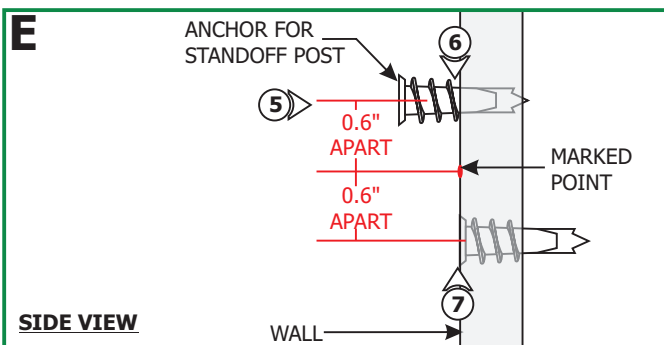

NOTE: The base holes should be in a vertical position at 90° angle to the direction of the fixture.

5: Mark additional points at 0.6" to the top & bottom of the drilled and marked points.

6: Use a hammer to tap in the anchors on the (new) marked points up to the threaded portion.

7: Screw in the threaded portion of the anchors with a Phillips screwdriver.

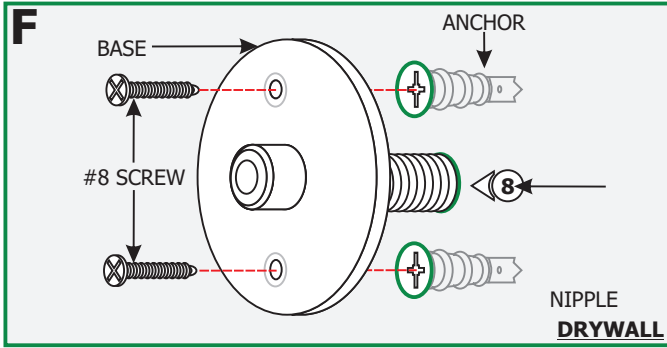

8: Insert the base nipple into the hole and secure using the two #8 screws provided.

9: Repeat step 8 for the other bases (without the nipple).

10: Power Feed Base Only: secure from behind the wall using the large washer and nut.

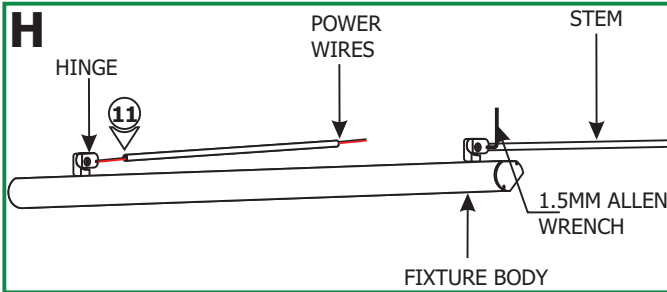
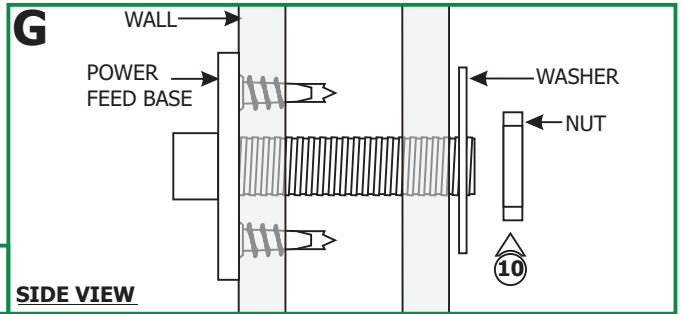

NOTE: It is recommended another person hold the fixture while the electrician connects the power to the fixture.

11: Feed the stem into the fixture hinges and secure by tightening the M3 set screw with the 1.5MM Allen wrench. **For the power feed hinge carefully run the power wires through the stem.**

12: While feeding the power wires into the base, slide the stems into the bases. Secure the stems in place by tightening the M4 set screw on the bases with 2MM Allen wrench.

13: Make all the proper wire connections. Refer to the power supply instructions for additional information. (General wiring diagram below).

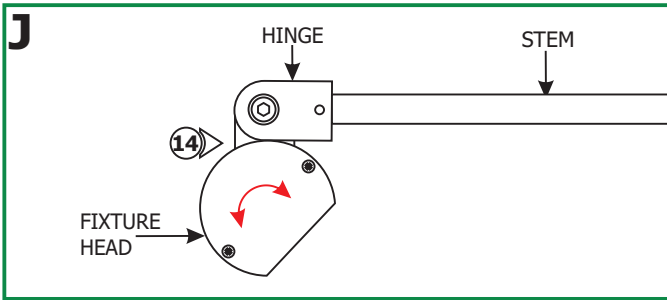
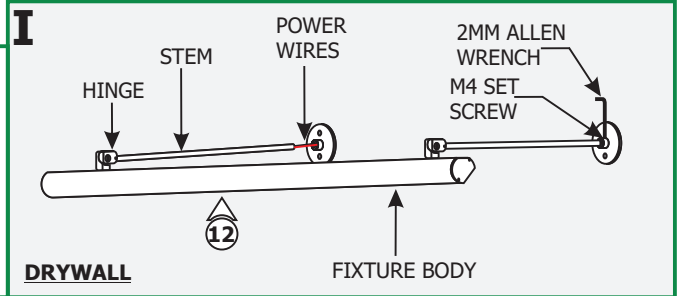

14: Rotate the fixture head to properly luminate the sign.

