

Installation Instructions for **Monorail 2 Circuit 2 X 250 Watt Sloped Surface Mount Magnetic Transformer 120 Volt Input to 12 Volt Single Feed Output**

SAVE THESE INSTRUCTIONS!

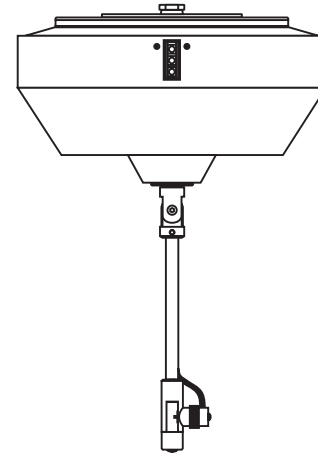

GENERAL INFORMATION

- **RISK OF FIRE:** This product must be installed by a qualified electrician. Turn the power to the electrical box off during installation. Read the "Important Safety Instructions" before installation.
- This product is suitable only for indoor dry locations and approved for the use at any height above the finished floor.
- This product contains a magnetic transformer with a built-in dimming coil.
- This product may be dimmed only with a low voltage magnetic dimmer. Using a dimmer other than specified may work initially, but will eventually cause transformer failure and void the warranty. The dimmer must be derated as indicated by the dimmer manufacturer.
- A typical installation is shown. Specific installation must be in accordance with the local electrical codes.
- Load each circuit of the surface mount transformer to **MAXIMUM 250** Watt.

IMPORTANT SAFETY INSTRUCTIONS

- Do not install this lighting system in a damp or wet location.
- Do not conceal or extend bus bar conductor through building wall.
- To reduce the risk of fire and burns, do not install this lighting system where the insulated open bus bar conductors can be shorted or contact any conductive materials.
- To reduce the risk of the system overheating and possibly causing a fire, make sure all the connections are tight.
- Do not install fixture assemblies closer than six inches, or as specified in the fixture installation instructions, to curtains or similarly combustible materials.
- Turn the electrical power off before modifying the lighting system in any way.
- The fixtures used with the Edge Lighting systems must be identified for use with the corresponding Edge Lighting systems.
- Minimum volume of the electrical box must be 6 cubic inches (98 cubic centimeters).
- The system is "ETL" listed for USA and Canada only when all the products used are supplied by Edge Lighting.

Install the Surface Mount Transformer

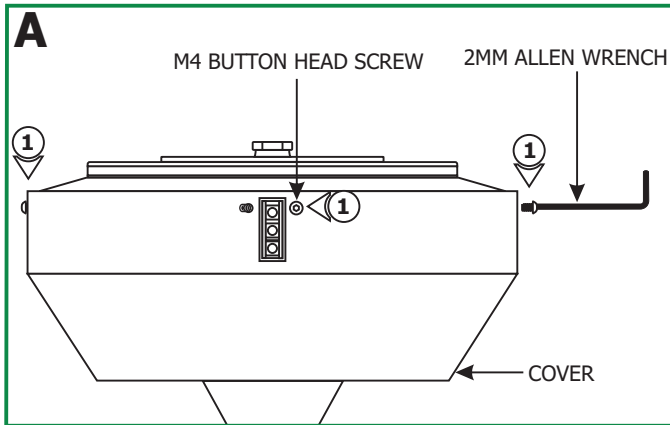

1: Loosen and remove the five M4 button head screws around the transformer cover with the provided 2mm Allen wrench.

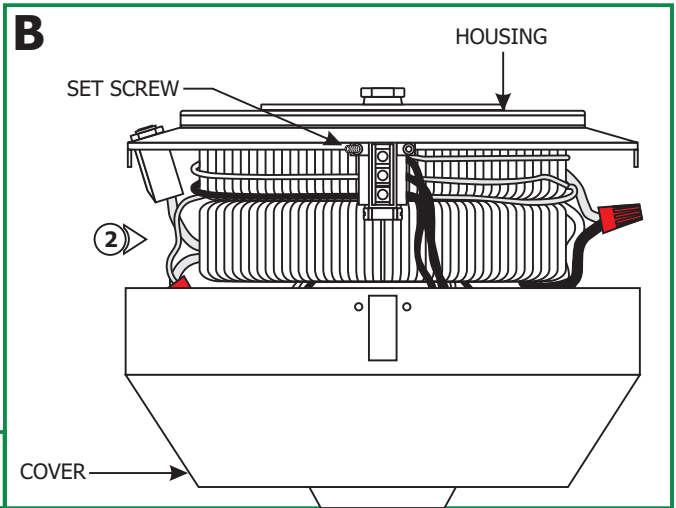

2: Unhook the transformer cover from the set screw and remove it from the transformer housing.

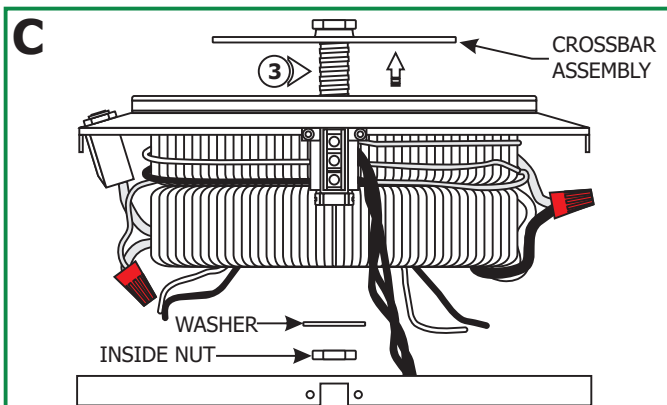

3: Remove the inside nut and washer to remove the crossbar assembly. **DO NOT DISASSEMBLE THE CROSSBAR ASSEMBLY.**

NOTE: The 120 volt transformer wires must be connected to the same phase of 120 volt power wires.

- 4:** Connect one set of provided white and black extension wires to the neutral and hot power wires coming from a switch respectively with the wire nuts provided.
- 5:** Connect the other set of provided white and brown extension wires to the neutral and hot power wires coming from the other switch respectively with the wire nuts provided.
- 6:** Feed the extension wires through the crossbar assembly nipple.
- 7:** Place all wires and wire nut connections inside the electrical box.
- 8:** Mount the crossbar assembly to the electrical box with the two provided #8-32 screws.
- 9:** Make sure the crossbar assembly is grounded in accordance with local electrical codes.

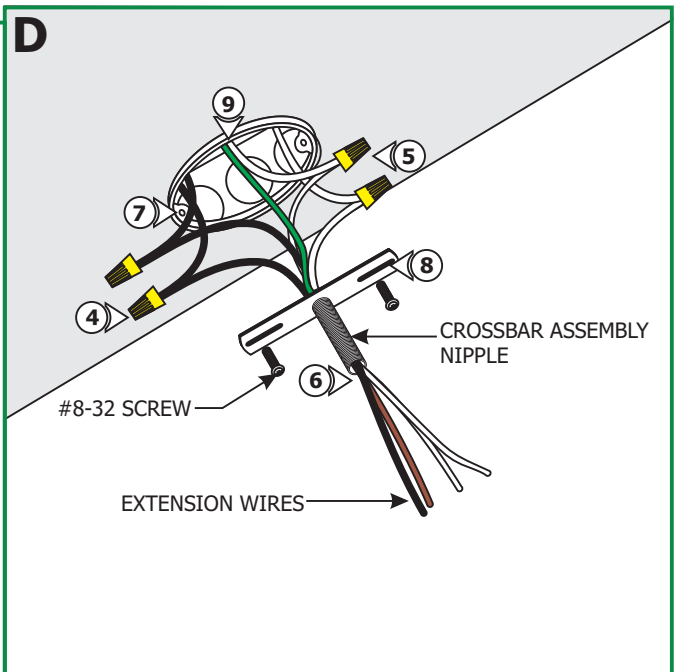

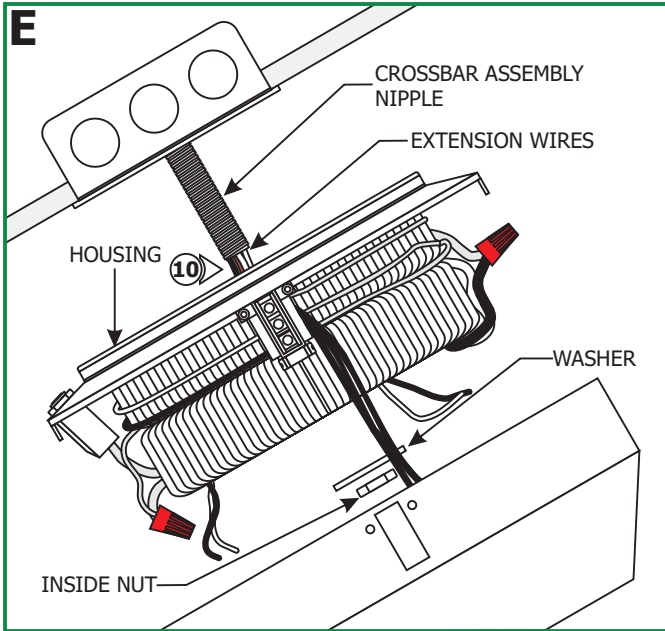

10: Feed the extension wires through the transformer housing center hole. Slide the transformer housing onto the crossbar assembly nipple and secure it in place by tightening the washer and inside nut.

- 11:** Connect the black and white 120 volt wires from the top transformer to one set of black and white extension wires respectively with wire nuts.
- 12:** Connect the black and white 120 volt wires from the bottom transformer to the other set of brown and white extension wires respectively with wire nuts.

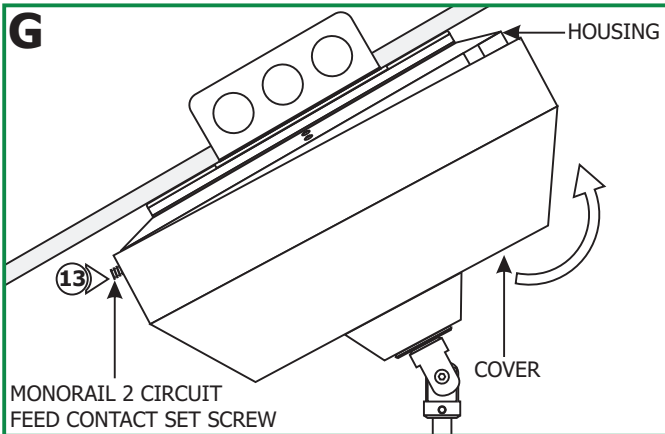
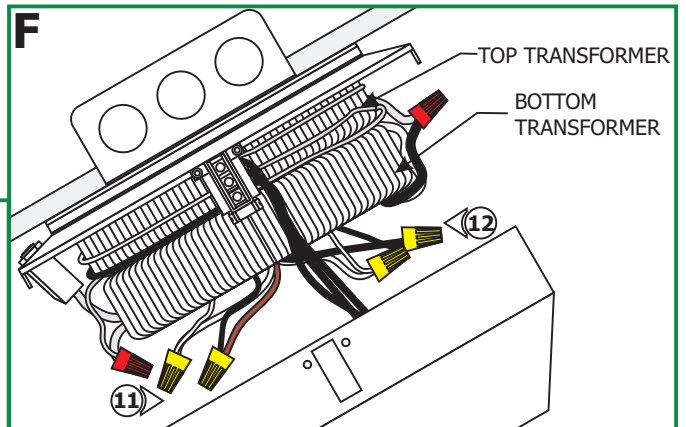

13: Hook one of the transformer cover screw holes next to the rectangle cutout, onto the Monorail 2 Circuit feed contact set screw.

14: Place the transformer cover onto the transformer housing. Replace and tighten the five M4 button head screws with the 2mm Allen wrench.

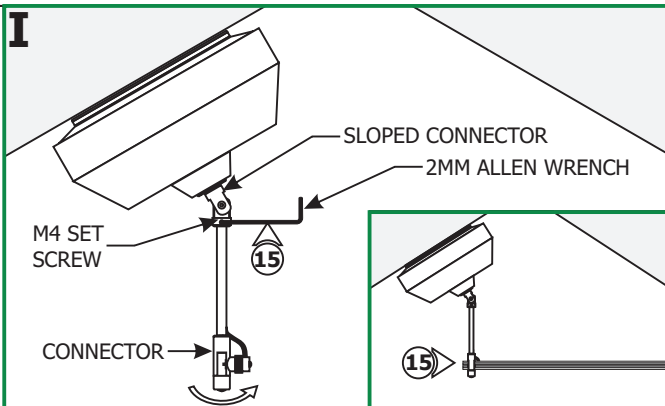
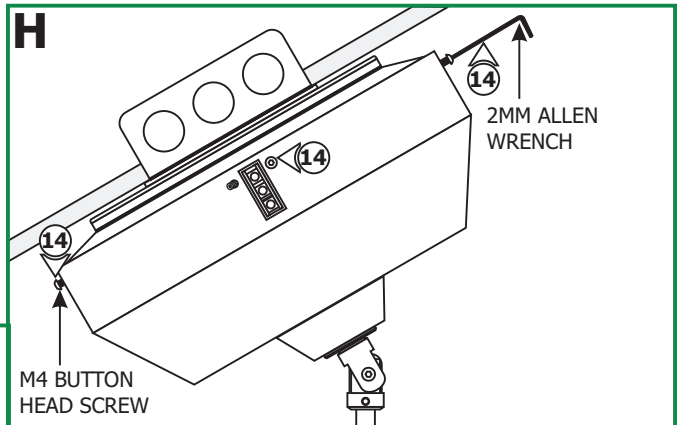

15: (OPTIONAL) To change the direction of the Monorail 2 Circuit, loosen the M4 set screw (**Do Not Remove**) on the sloped connector. Rotate the Monorail 2 Circuit connector to desired direction. While pushing the Monorail 2 Circuit connector to the sloped connector, tighten the M4 set screw with the 2mm Allen wrench.

Install the Monorail 2 Circuit to the Transformer

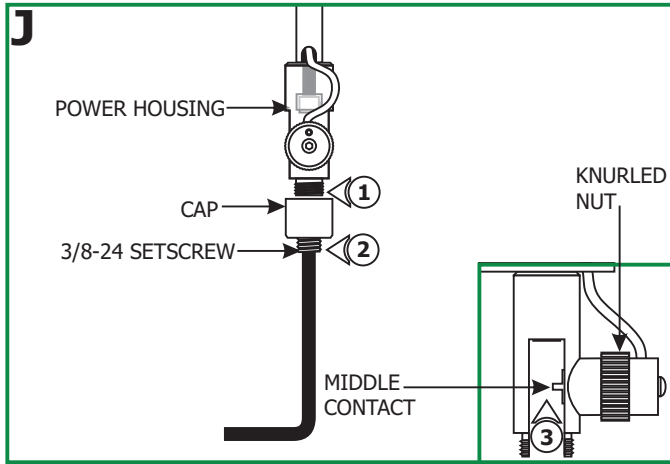

NOTE: The proper size standoffs should be installed to support the Monorail 2 Circuit while connecting Monorail 2 Circuit to the surface mount transformer (refer to the instructions provided with the standoffs).

- 1: Unscrew the cap from the power housing.
- 2: Slightly loosen the 3/8-24 set screw on the cap with the 3/16 Allen wrench provided, **(DO NOT REMOVE IT)**.
- 3: Slightly loosen the knurled nut on the power housing so that the middle contact moves back and clears the power housing opening.

- 4: Place the Monorail 2 Circuit into the power housing and support it with the sloped standoffs (refer to the instructions provided with the sloped standoffs).
- 5: Tighten the cap to the power housing. **Make sure the cap is not cross threaded.**

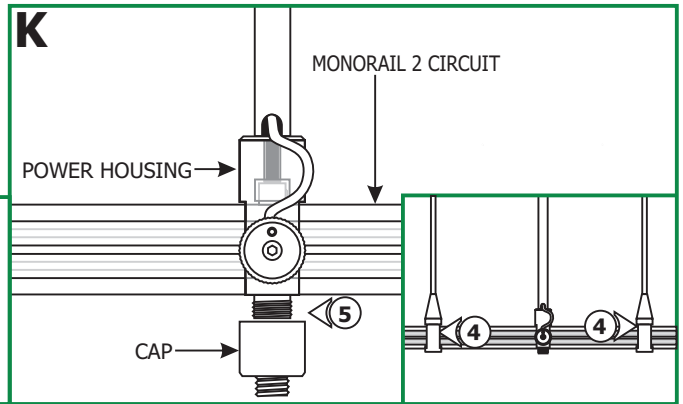

- 6: Tighten the 3/8-24 set screw on the cap with the 3/16 Allen wrench for proper power connection.
- 7: Tighten the knurled nut for proper power connection.

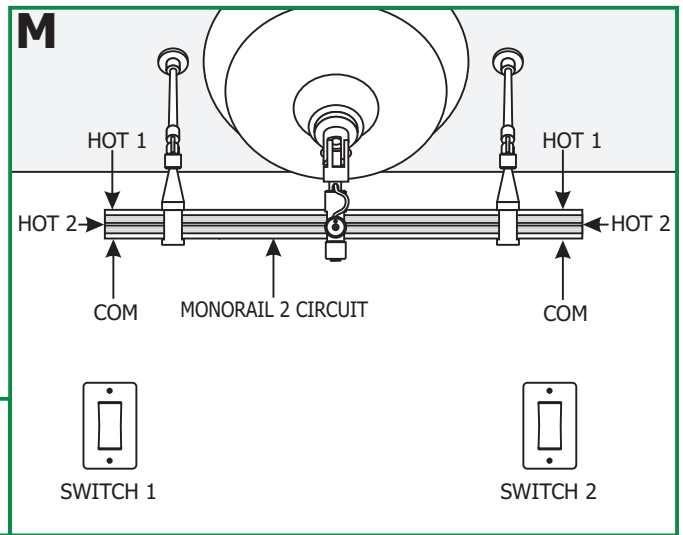
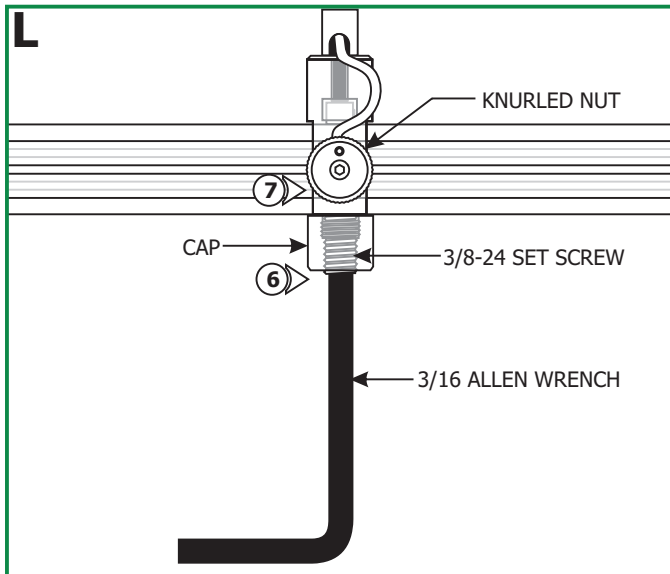

NOTE: Switch 1 turns on/off the circuit 1 (COM & HOT 1) and Switch 2 turns on/off circuit 2 (COM & HOT 2). Load each circuit of Monorail 2 Circuit to **MAXIMUM 250** watt.