

## Installation Instructions for Monorail Adjustable Power Feed

### IMPORTANT INFORMATION

- This product is ETL listed for indoor dry locations.
- The product is intended to be used with Edge Lighting Monorail surface mount transformers only.
- This product jumps the power from the transformer to the Monorail.

**SAVE THESE INSTRUCTIONS!**

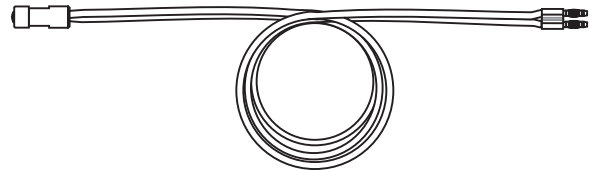

## Install the Monorail Adjustable Power Feed

**A**

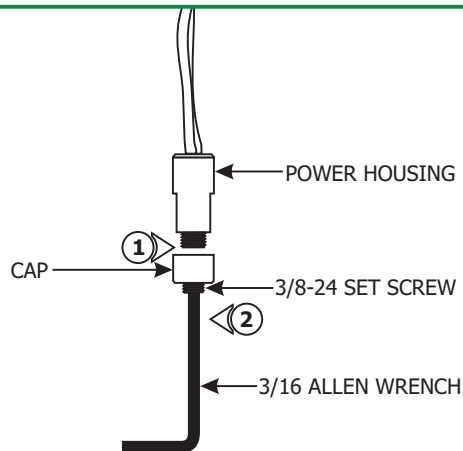

**NOTE:** The entire Monorail system should be installed before connecting the adjustable power feed (refer to the instructions provided with each product for further details).

- 1: Unscrew the cap from the power housing.
- 2: Slightly loosen the 3/8-24 set screw on the cap with the 3/16 Allen wrench provided, **DO NOT REMOVE IT.**

**3:** Place the power housing onto the Monorail and tighten the cap to the power housing. **Make sure the cap is not cross threaded.**

**4:** Tighten the 3/8-24 set screw with the 3/16 Allen wrench provided on the cap firmly for proper power connection.

**B**

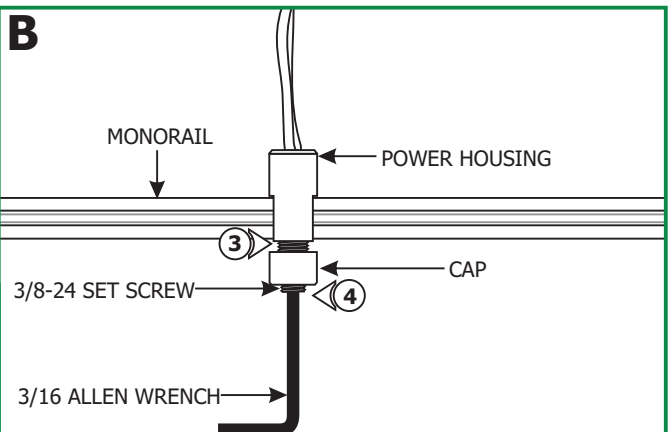

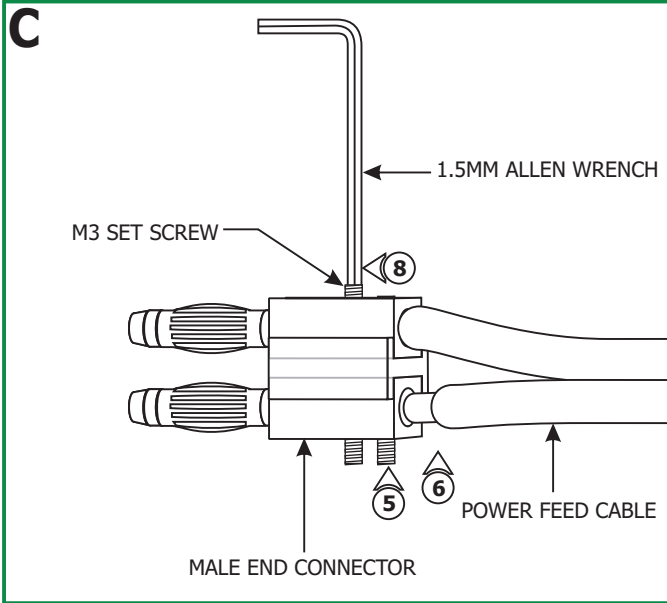

**5: (OPTIONAL)** To shorten the adjustable power feed cable, loosen the four M3 set screws on the male end connector (**Do Not Remove**) with the 1.5mm Allen wrench provided.

**6:** Remove the male end connector and trim the adjustable power feed cable to the desired length.

**7:** Strip 3/8" off of the insulation from the end of the wires.

**8:** Insert the stripped portion of the wires completely into the male end connector and tighten the four M3 set screws firmly with the 1.5mm Allen wrench.

**NOTE:** The 12 volt 600 watt, dual feed Monorail surface mount transformer, MT-600-12-\_\_ models require two Monorail adjustable power feed, one for each feed contact.

**9:** Push the male end connector completely into the Monorail surface mount transformer feed contact.

