

Installation Instructions for **Monorail 600 Watt Extended Surface Mount Magnetic Transformer 120 Volt Input to 24 Volt Single Feed Output**

SAVE THESE INSTRUCTIONS!

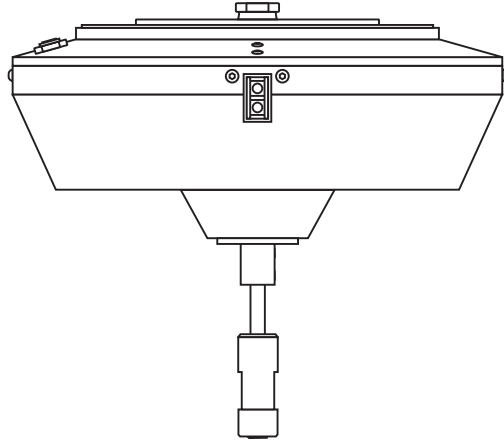

GENERAL INFORMATION

- **RISK OF FIRE:** This product must be installed by a qualified electrician. Turn the power to the electrical box off during installation. Read the "Important Safety Instructions" before installation.
- This product is suitable only for indoor dry locations and approved for the use at any height above the finished floor.
- This product contains a magnetic transformer with a built-in dimming coil.
- This product may be dimmed only with a low voltage magnetic dimmer. Using a dimmer other than specified may work initially, but will eventually cause transformer failure and void the warranty. The dimmer must be derated as indicated by the dimmer manufacturer.
- A typical installation is shown. Specific installation must be in accordance with the local electrical codes.
- Load the circuit of the surface mount transformer to **MAXIMUM 600** Watt.

IMPORTANT SAFETY INSTRUCTIONS

- Do not install this lighting system in a damp or wet location.
- Do not conceal or extend bus bar conductor through building wall.
- To reduce the risk of fire and burns, do not install this lighting system where the insulated open bus bar conductors can be shorted or contact any conductive materials.
- To reduce the risk of the system overheating and possibly causing a fire, make sure all the connections are tight.
- Do not install fixture assemblies closer than six inches, or as specified in the fixture installation instructions, to curtains or similarly combustible materials.
- Turn the electrical power off before modifying the lighting system in any way.
- The fixtures used with the Edge Lighting systems must be identified for use with the corresponding Edge Lighting systems.
- Minimum volume of the electrical box must be 6 cubic inches (98 cubic centimeters).
- The system is "ETL" listed for USA and Canada only when all the products used are supplied by Edge Lighting.

Install the Surface Mount Transformer

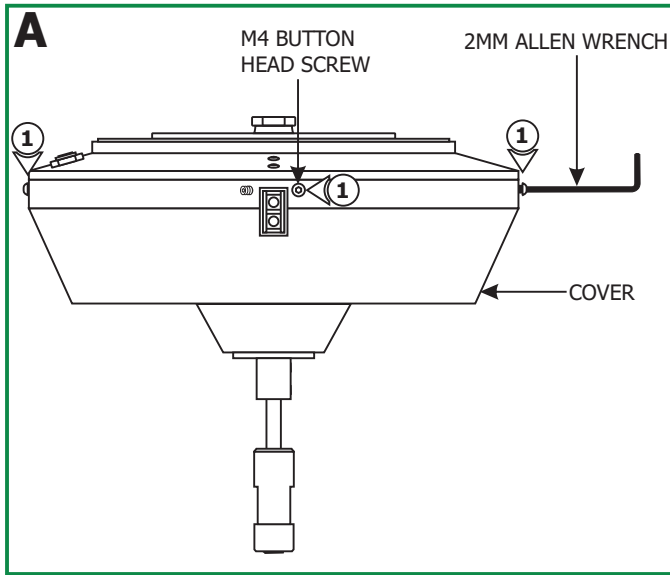

NOTE: If necessary adjustments can be made to the height of the power feed rod by following steps "Shortening the Power Feed Rod Height" on page 5.

1: Loosen and remove the five M4 button head screws around the transformer cover with the provided 2mm Allen wrench.

2: Unhook the transformer cover from the set screw and remove it from the transformer housing.

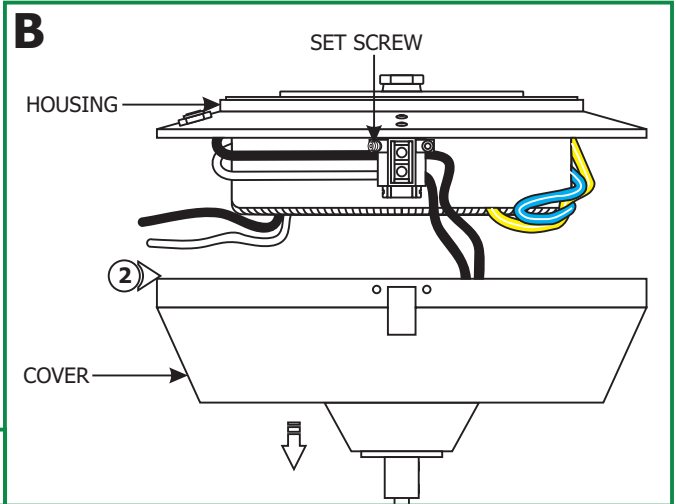

3: Remove the inside nut and washer to remove the crossbar assembly. **DO NOT DISASSEMBLE THE CROSSBAR ASSEMBLY.**

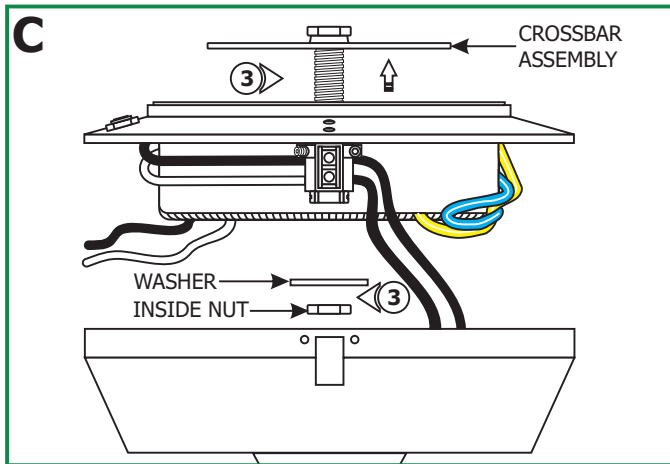

4: Connect the provided white and black extension wires to the neutral and hot power wires respectively with the wire nuts provided.

5: Feed the wires through the crossbar assembly nipple.

6: Place all wires and wire nut connections inside the electrical box.

7: Mount the crossbar assembly to the electrical box with the two provided #8-32 screws.

8: Make sure the crossbar assembly is grounded in accordance with local electrical codes.

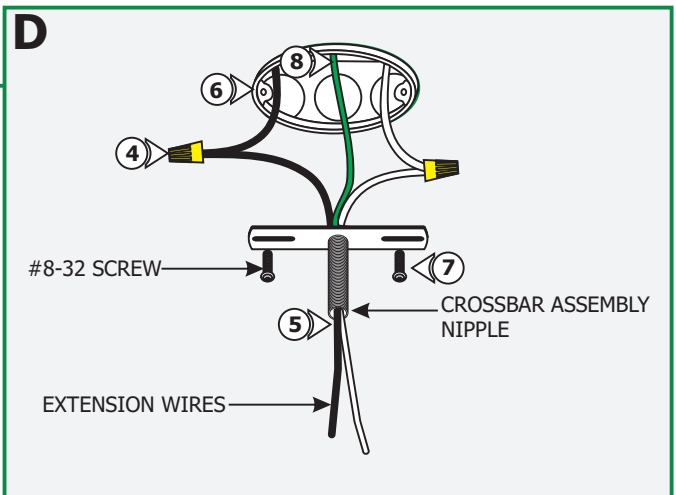

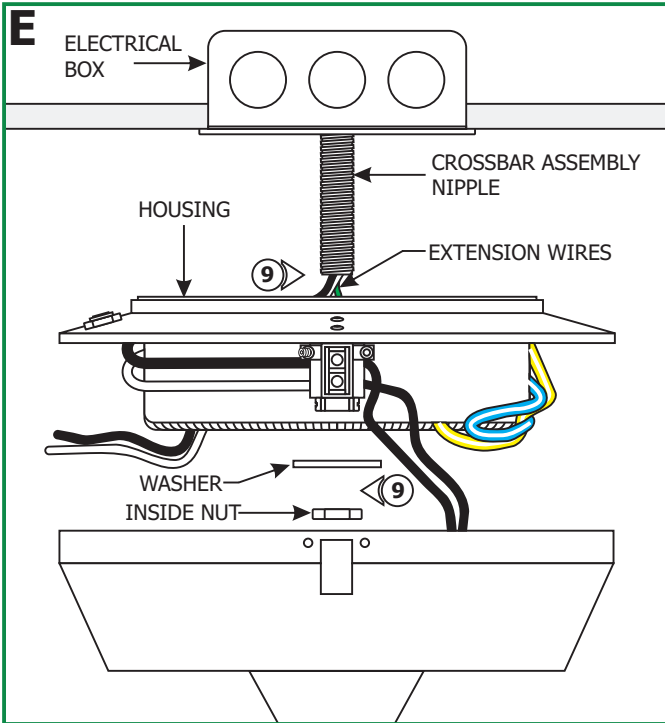

9: Feed the extension wires through the transformer housing center hole. Slide the transformer housing onto the crossbar assembly nipple and secure it in place by tightening the washer and inside nut.

- 10:** Connect the white transformer wire to the neutral power wire with a wire nut.
- 11:** Connect the black transformer wire to the hot power wire with a wire nut.

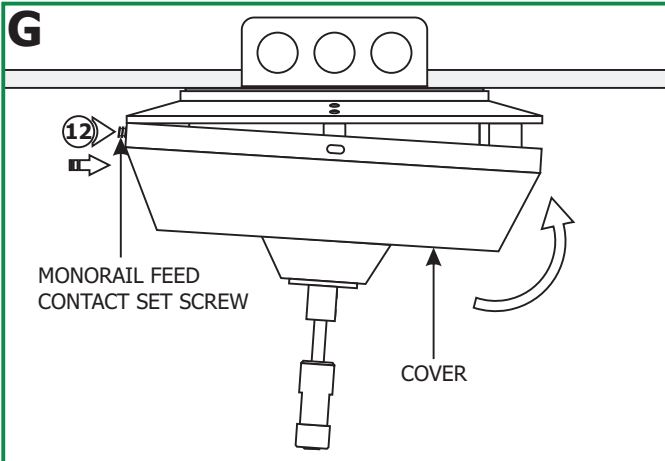
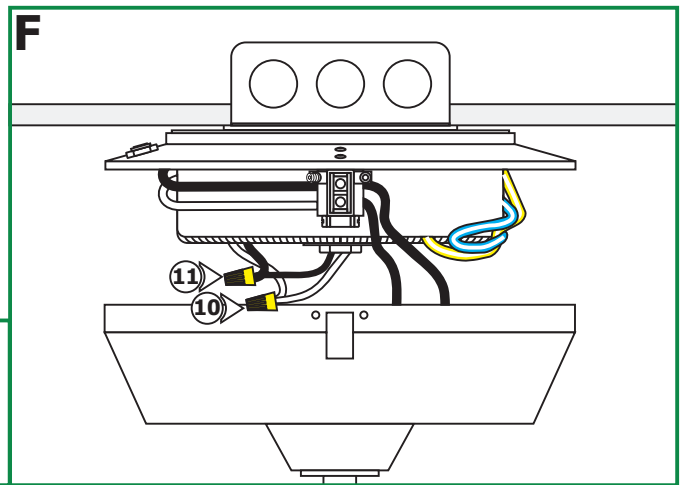

12: Hook one of the transformer cover screw holes next to the rectangle cutout, onto the Monorail feed contact set screw.

13: Place the transformer cover onto the transformer housing. Replace and tighten the five M4 button head screws with the 2mm Allen wrench.

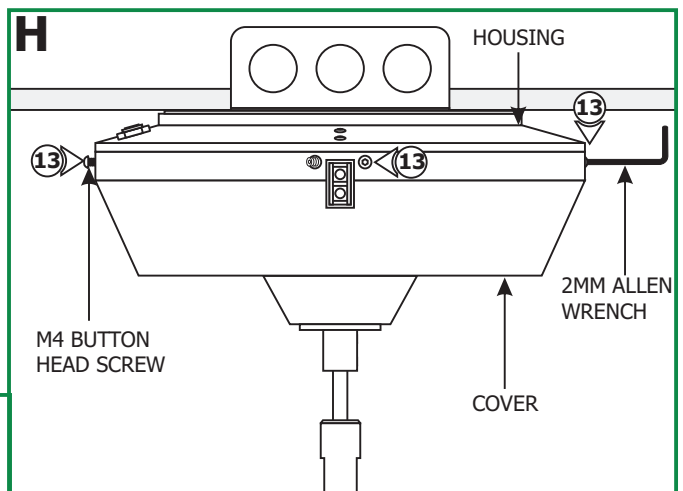

Install the Monorail to the Transformer

I

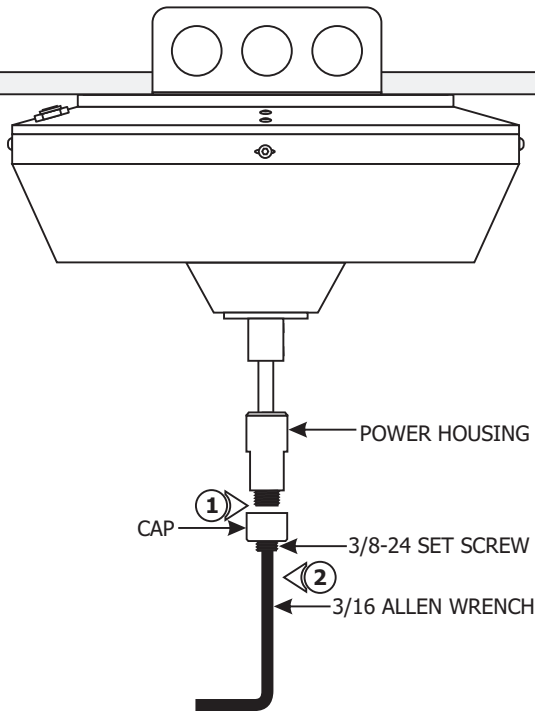

NOTE: The proper size standoffs should be installed to support the Monorail while connecting Monorail to the surface mount transformer (refer to the instruction provided with the standoffs).

- 1:** Unscrew the cap from the power housing.
- 2:** Slightly loosen the 3/8-24 set screw on the cap with the 3/16 Allen wrench provided, **DO NOT REMOVE IT.**

J

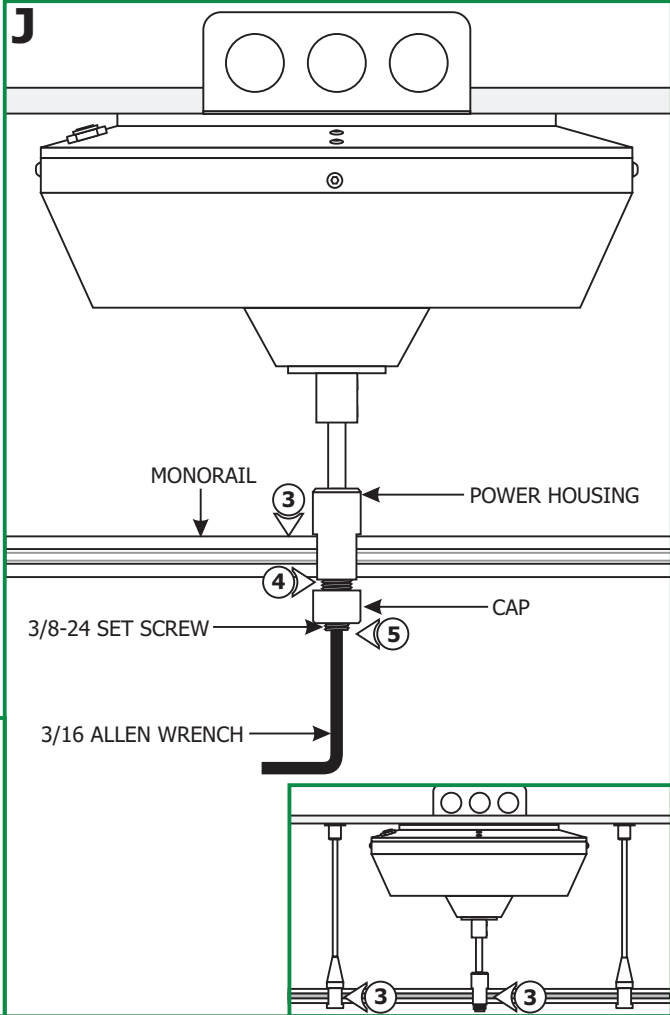

- 3:** Place the Monorail into the power housing and support it with the standoffs (refer to the instructions provided with the standoffs).
- 4:** Tighten the cap to the power housing. **Make sure the cap is not cross threaded.**
- 5:** Tighten the 3/8-24 set screw with the 3/16 Allen wrench provided on the cap firmly for proper power connection.

K

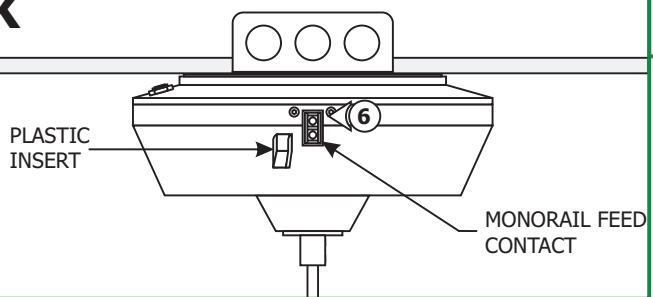

- 6:** Plug the Monorail feed contacts with the provided plastic inserts.

Shortening the Power Feed Rod Height

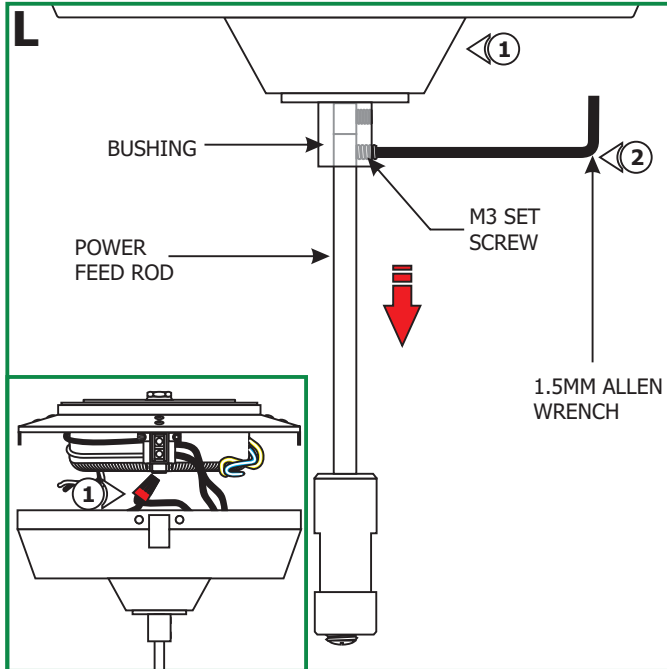

- 1:** Remove the wire nut from the center wire.
- 2:** Loosen (**DO NOT REMOVE**) the bottom M3 set screw on the bushing and carefully pull out the power feed rod along with the center wire.

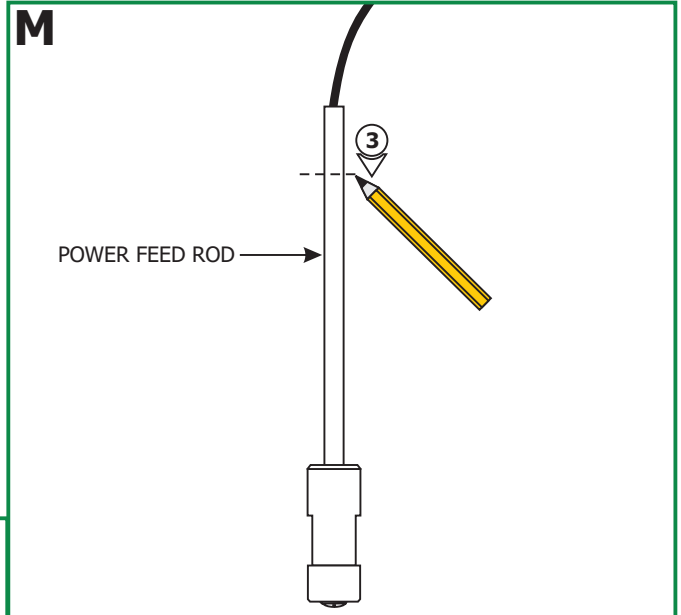

- 3:** From the end of the power feed rod mark the rod to the amount that needs to be shortened. For example to resize 24" standoff to 17", mark 7" from the end of the power feed rod.

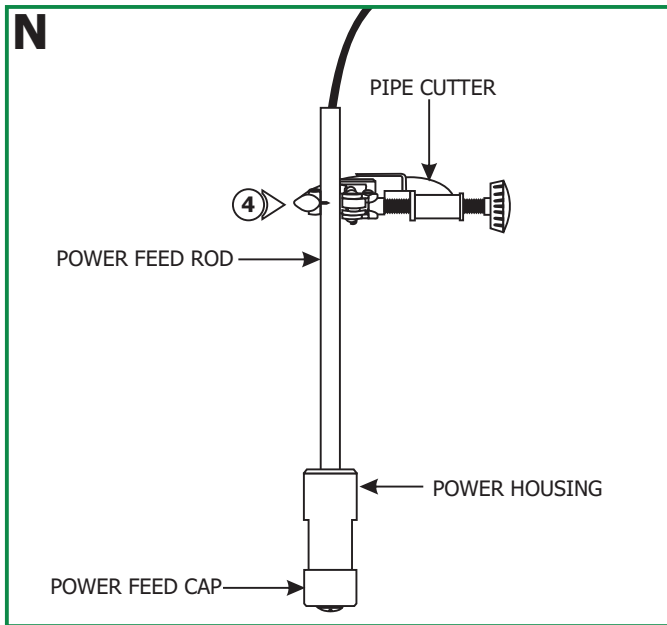

- 4:** Use a pipe cutter to cut out the excess rod. If cutting with a hacksaw, then make sure the center wire is removed from the rod. To remove the center wire, remove the power feed cap, pull the wire out. Make sure to clean the burr of the cut section before re-feeding the center wire.

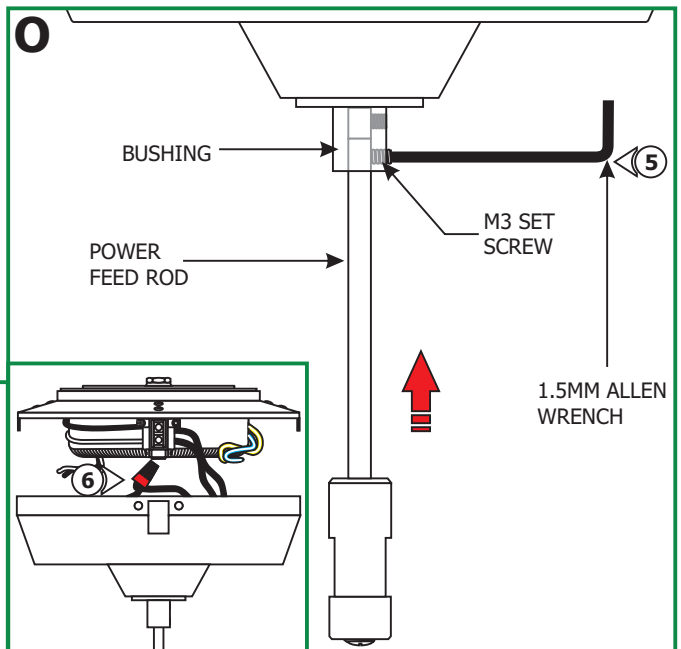

- 5:** Feed the center wire through the bushing inserting the power feed rod completely inside the bushing. Tighten the bottom M3 set screw with the 1.5mm Allen wrench.
- 6:** Connect the center wire to the loose transformer wire with a wire nut.
- 7:** Follow the "Install the Surface Mount Transformer" steps on page 2.