

Installation Instructions for Monorail Wall 2" Square Power Feed Canopy

IMPORTANT INFORMATION

- This product is ETL listed for indoor dry locations.
- This product installs to Edge Lighting 2" electrical box only.
- Minimum electrical box volume must be 6 cubic inches (98 cubic centimeter).
- This product should be installed by a qualified electrician.

SAVE THESE INSTRUCTIONS!

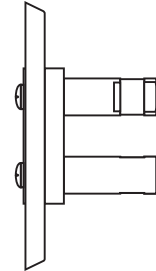

Install the Canopy

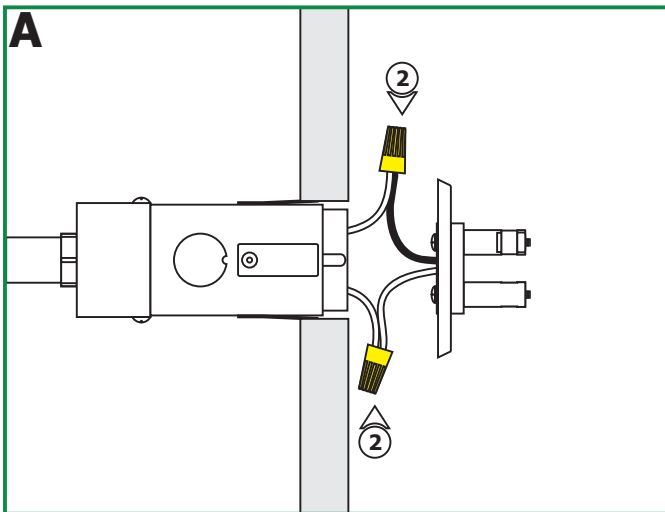

NOTE: The low voltage wires should be present in the 2" electrical box. Refer to the instructions provided with the remote transformer to install the transformer and the low voltage wires before proceeding with the steps below.

- 1: Turn the power to the 2" electrical box off.
- 2: Connect each low voltage wire coming from the remote transformer to one power feed canopy wire with a wire nut.

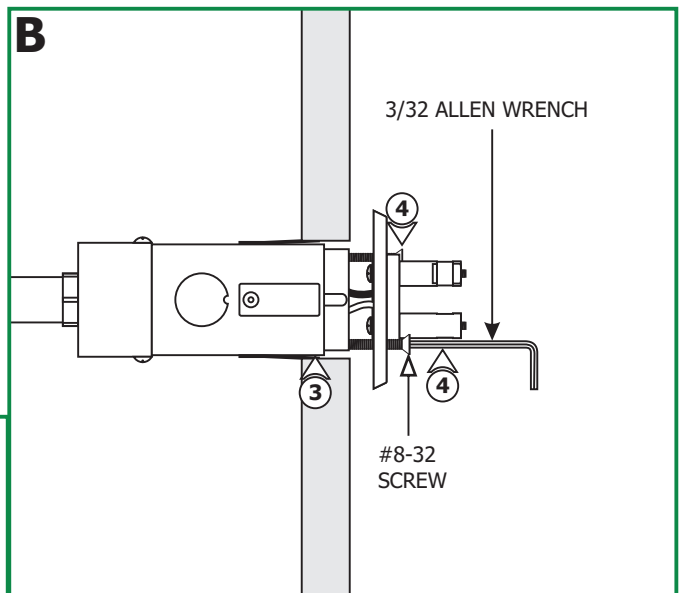

- 3: Place all wires inside the 2" electrical box.
- 4: Secure the power feed canopy to the 2" electrical box by tightening the two provided #8-32 screws with the 3/32 Allen wrench.

Install the Monorail to Power Feed Canopy

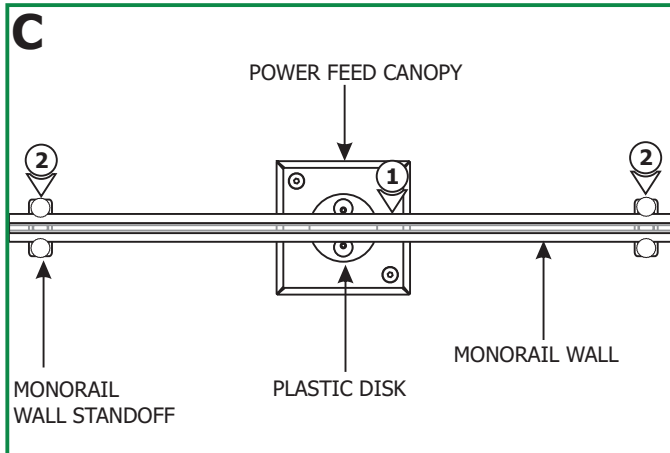

- 1:** Make sure that the Monorail wall standoffs are inline with the power feed canopy so that the Monorail fits into center of the standoffs and the center of the power feed canopy plastic disk.
- 2:** Secure the Monorail to the Monorail wall standoffs (refer to the instructions provided with Monorail wall standoff).

- 3:** Rotate the power feed canopy plastic disk so that one of the connector's slot slides completely onto the top rail and the other connector's slot slides completely onto the bottom rail of the Monorail.
- 4:** Tighten the M3 set screw on each power feed connector with 1.5mm Allen wrench provided.

