

Installation Instructions for **100 Watt 12 Volt DC LED Power Supply**

SAVE THESE INSTRUCTIONS!

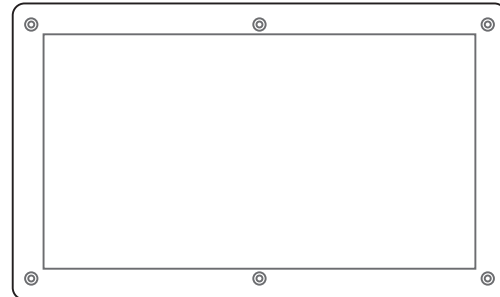

GENERAL INFORMATION

- **RISK OF FIRE:** This product must be installed by a qualified electrician. Turn the power to the electrical box off during installation. Read the "Important Safety Instructions " before installation.
- This product is not suitable for wet locations. It is approved for the use at any height above the finished floor.
- A typical installation is shown. Specific installation must be in accordance with the local electrical codes.
- **TO REDUCE RISK OF FIRE,** it is important to wire the power supply for the system as described in this installation instruction.
- Load the power supply to **MAXIMUM 100** Watts.

IMPORTANT SAFETY INSTRUCTIONS

- Do not install this power supply in a wet location.
- To reduce the risk of the system overheating and possibly causing a fire, make sure all the connections are tight.
- Do not install *LED fixture closer than three inches or as specified in the *LED fixture installation instructions to curtains or similarly combustible materials. Keep insulation at least 3" away from the enclosure.
- Turn the electrical power off before modifying the lighting system in any way.
- The system is "ETL" listed for USA and Canada only when all the products used are supplied by Edge Lighting.
- * See LED fixture installation instructions for proper placement.

100W, 12VAC LOW VOLTAGE WIRE SIZE CHART

3% VOLTAGE DROP	WIRE LENGTH IN FT	UP TO 8FT	9FT-12FT	13FT-20FT	21FT-31FT	32FT-49FT
	WIRE SIZE	14 AWG	12 AWG	10 AWG	8 AWG	6 AWG
	VOLTAGE AT END OF THE WIRE	11.64 VAC	11.65 VAC	11.65 VAC	11.64 VAC	11.64 VAC

Using LED Power Supply with a Light Switch & Warm White Soft Strip (Non-Dimmable)

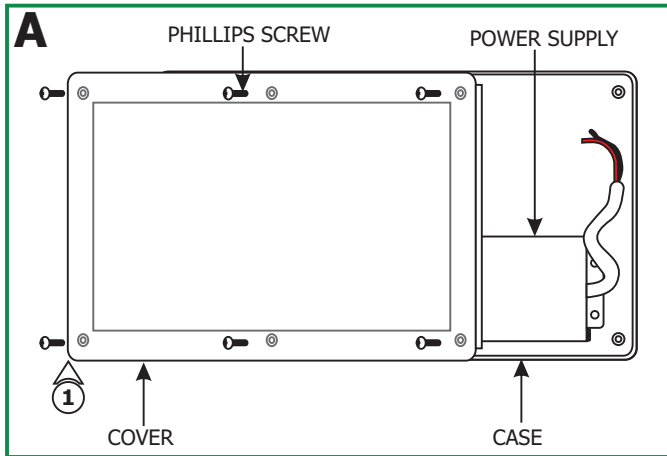

1: Loosen the six Phillips screws on front of the power supply to remove the cover.

- 2:** Install conduits from the light switch, main panel (line voltage) and soft strip to the power supply case.
- 3:** Run proper size wires from the light switch electrical box to the power supply case.
- 4:** Run the line voltage power wires from the panel to the power supply case.

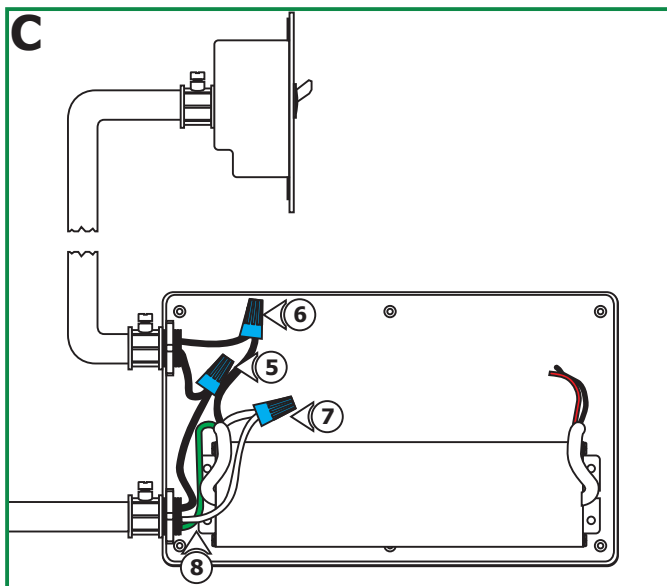
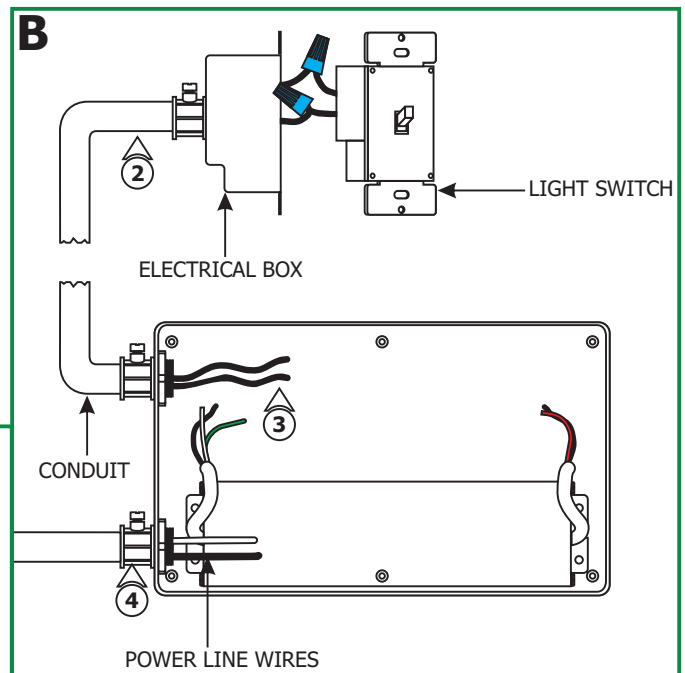

- 5:** Connect the hot power wire to one of the wires coming from the switch with a wire nut.
- 6:** Connect the other switch wire to the black power supply wire with a wire nut.
- 7:** Connect the neutral power wire to white power supply wire with a wire nut.
- 8:** Make sure the green transformer wire is grounded in accordance with local electrical codes.

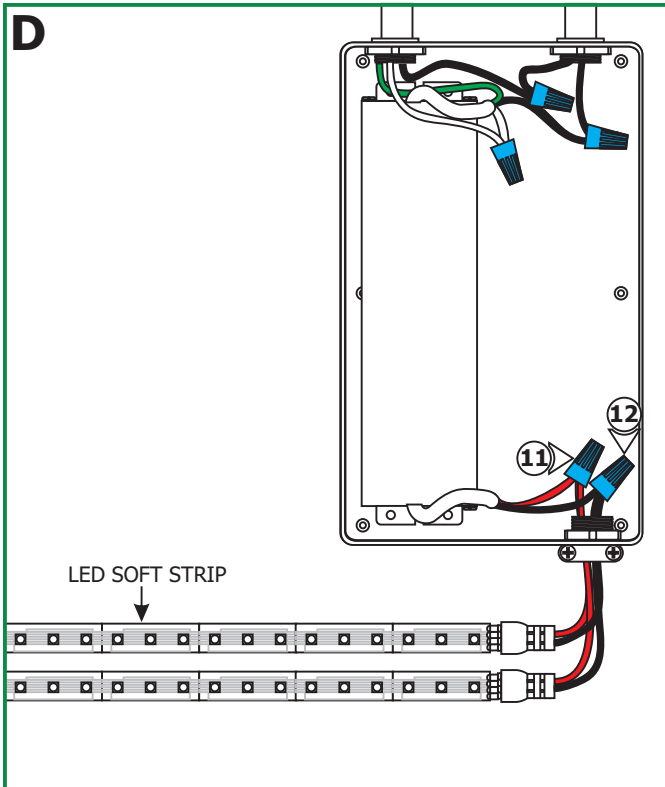

9: Use the "Low Voltage Wire Size Chart" on page 1 to determine the proper wire size connecting the power supply to the LED soft strip.

10: Run the proper size, red and black wires from the power supply case to the LED soft strip.

NOTE: Do not exceed the maximum wattage of the power supply.

NOTE: Use only 12 volt LED soft strip with this power supply.

11: Connect the red power supply wire to red soft strip wire(s).

12: Connect the black power supply wire to black soft strip wire(s).

13: Replace the power supply cover and secure it by tightening the six Phillips screws.

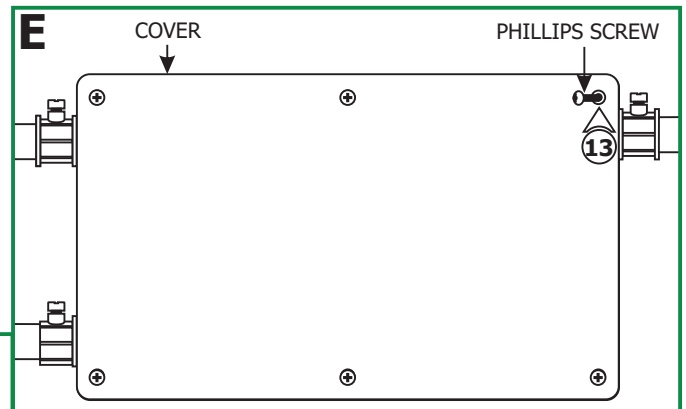

Using LED Power Supply with RGB Soft Strip & CDP or CTP Controller

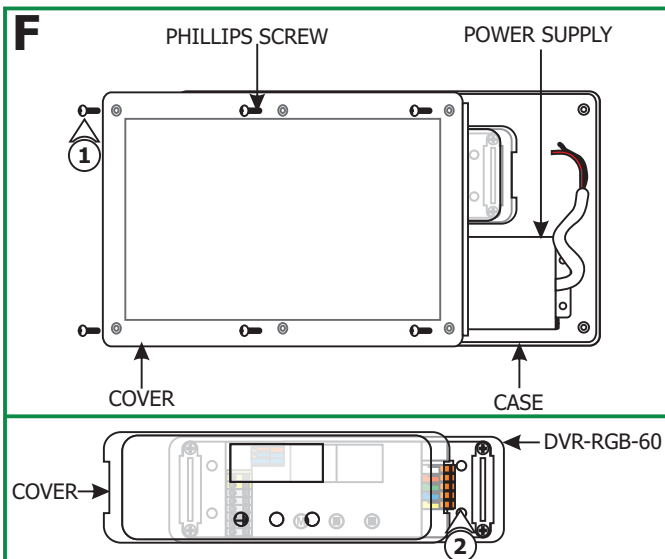

NOTE: Refer to the instructions provided with the CDP (Color Dial Controller) or CTP (Color Touch Screen Controller) to install, power, and program them. This section shows typical CDP controller installation.

1: Loosen the six Phillips screws on front of the power supply to remove the cover.

NOTE: Use a DVR-RGB-60 (Sold Separately) with this power supply.

2: Carefully pull off the cover from the DVR-RGB-60 driver.

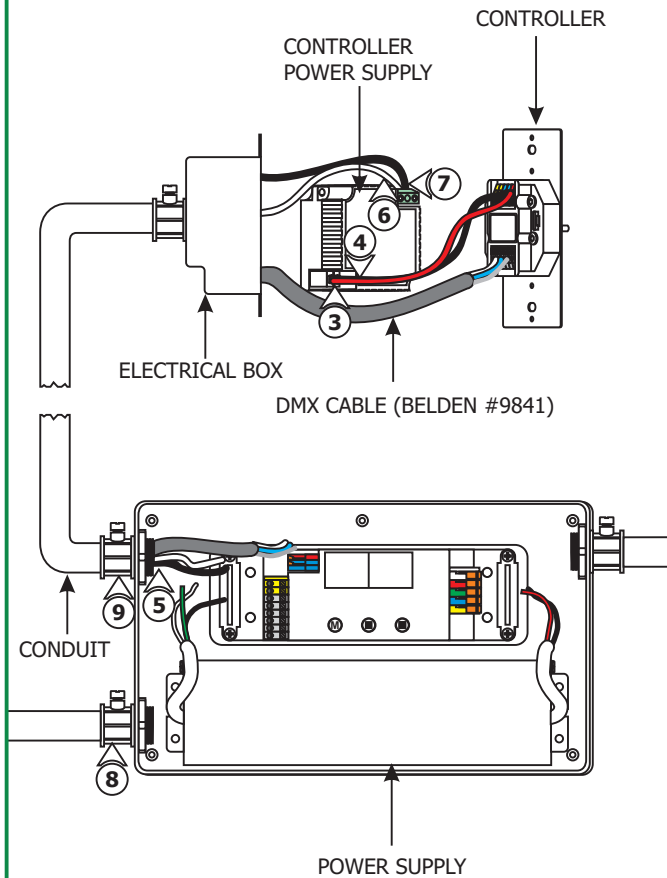
G

NOTE: Use a deep double gang boxes to fit the controller and controller power supply (OT-20-120-240-245 recommended).

NOTE: Refer to the "Configuring DimWheel" & "Operating DimWheel" on page 6 & 7 to properly operate the controller.

- 3:** Connect one end of a red wire to "VDC+" of the controller terminal and the other end of the red wire to the "+24VDC" of the power supply terminal.
- 4:** Connect one end of a black wire to "Ground" of the controller terminal and the other end to the "-24VDC" of the power supply terminal.
- 5:** Run the black and white line voltage wires coming from the controller power supply to the power supply case.
- 6:** Connect the white wire to "N" terminal of the controller power supply.
- 7:** Connect the black wire to "L" terminal of the controller power supply.
- 8:** Install conduits from controller, main panel (line voltage), and soft strip to power supply.
- 9:** Run proper DMX cable (**Belden #9841 recommended**) with three data wires from controller to the power supply box.

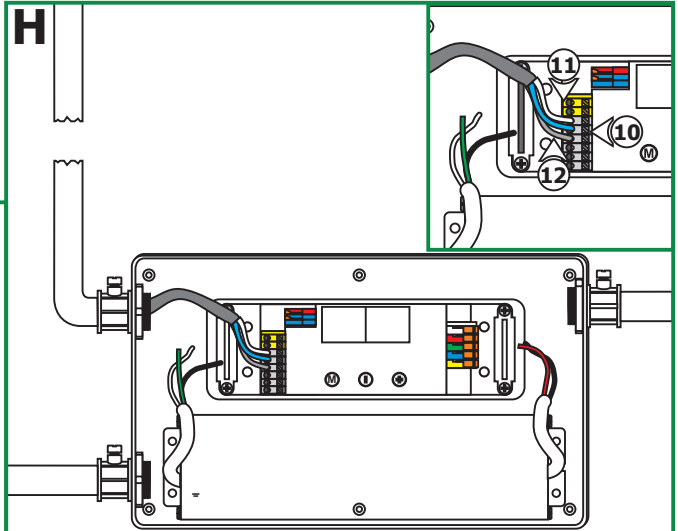
H

10: Connect one end of a data wire (blue with white stripes wire) to controller "LEDSYNC OUT -" terminal. Connect the other end into the DVR-RGB-60 "DMX in -" terminal.

11: Connect one end of a data wire (white with blue stripes wire) to controller "LEDSYNC OUT +" terminal. Connect the other end into the DVR-RGB-60 "DMX in +" terminal.

12: Connect one end of a data wire (bare shield wire) to controller "LEDSYNC SHIELD" terminal. Connect the other end into the DVR-RGB-60 "DMX in shield" terminal.

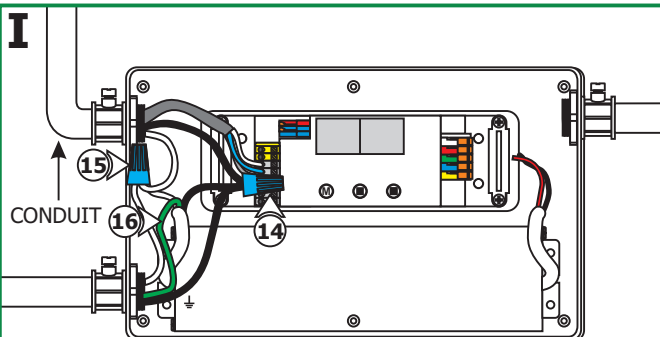
I

13: Run the line voltage power wires into the power supply.

14: Connect the hot power wire to black power supply wire and black wire coming from the controller power supply with a wire nut.

15: Connect the neutral power wire to white power supply wire and white wire coming from the controller power supply with a wire nut.

16: Make sure the green transformer wire is grounded in accordance with local electrical codes.

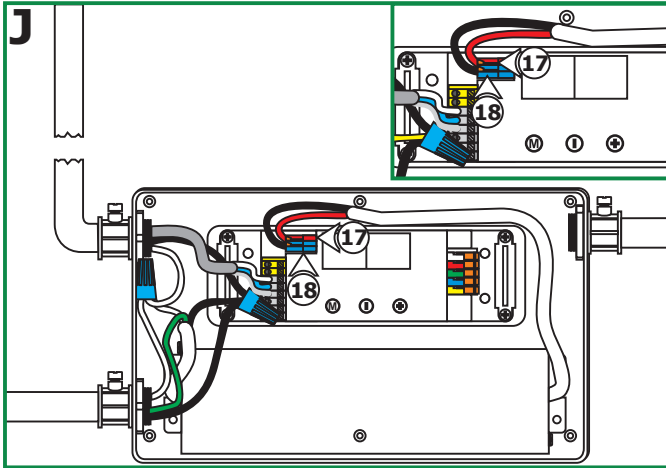

- 17:** Connect the red power supply wire to DVR-RGB-60 "Vdc+" red terminal.
- 18:** Connect the black power supply wire to DVR-RGB-60 "Vdc-" blue terminal.

NOTE: The DVR-RGB-60 terminals adapt maximum 18 AWG size. To avoid voltage drop, use 6" of 18 AWG size in RGB terminals connected inline to proper size gauge wire attached to the RGB LED wires with wire nuts. See the "Low Voltage Wire Size Chart" on page 1.

- 19:** Use the "Low Voltage Wire Size Chart" on page 1 to determine proper wire size connecting to the DVR-RGB-60 terminals.
- 20:** Run the proper size green, red, blue, and black wires from the RGB LED soft strip to the power supply case.

NOTE: Do not exceed the maximum wattage of the power supply.

NOTE: Use only 12 volt LED RGB soft strip with this power supply.

- 21:** Run the proper size green, red, blue, and black wires from the RGB LED soft strip to the power supply case.
- 22:** Connect the black wire into DVR-RBG-60 "LED SUPPLY +" white terminal. Connect the other end to RGB soft strip black wire(s).
- 23:** Connect the red wire into DVR-RBG-60 "Group 1-" red terminal. Connect the other end to RGB soft strip red wire(s).
- 24:** Connect the green wire into DVR-RBG-60 "Group 2-" green terminal. Connect the other end to RGB soft strip green wire(s).
- 25:** Connect the blue wire into DVR-RBG-60 "Group 3-" blue terminal. Connect the other end to RGB soft strip red wire(s).

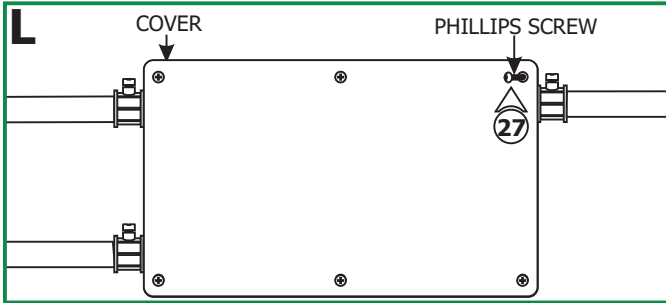
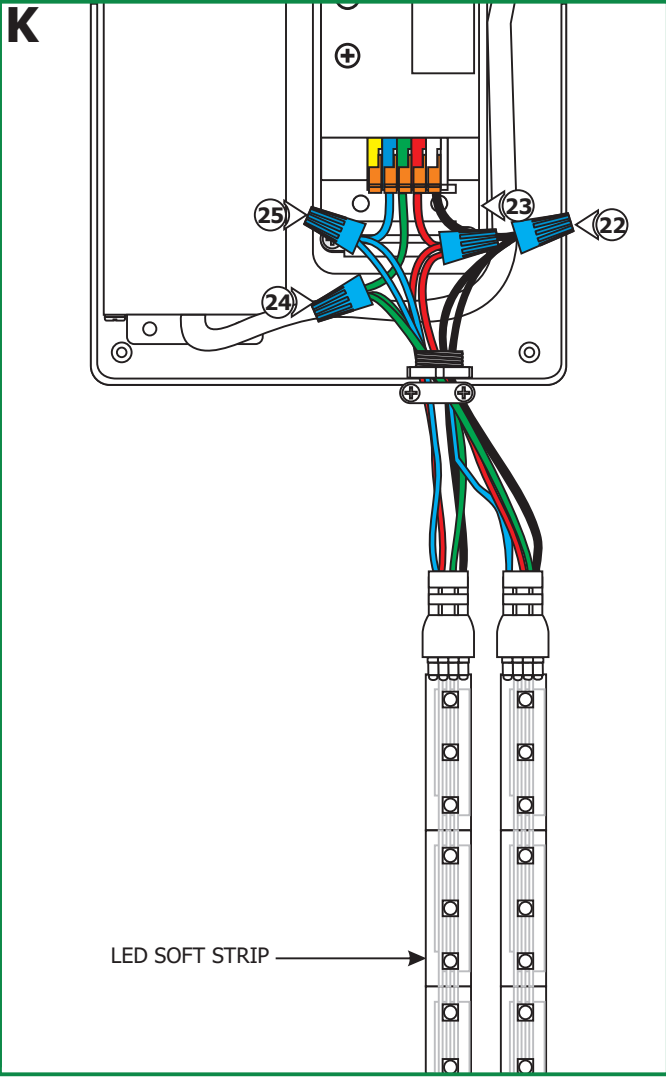

- 26:** Replace the DVR-RGB-60 cover.
- 27:** Replace the power supply cover and secure it by tightening the six Phillips screws.

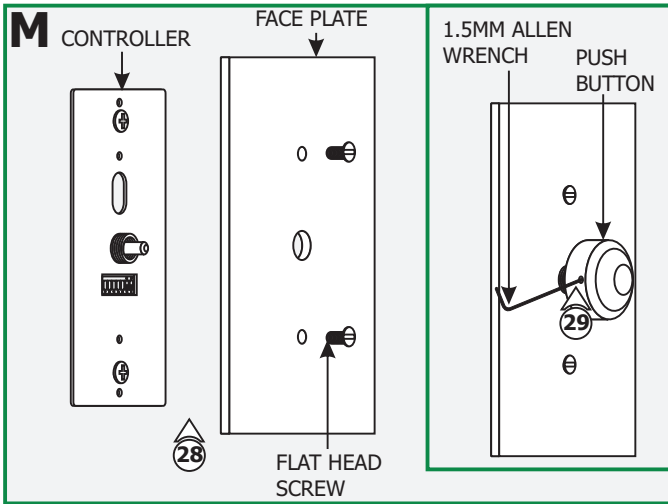

28: Align the face plate to the controller and secure using the two flat head screws.

29: Attach the push button onto the controller center rod and secure by tightening the M3 set screw with the 1.5mm Allen wrench provided.

Wiring Diagrams

Using LED Power Supply with Warm White Soft Strip & Switch

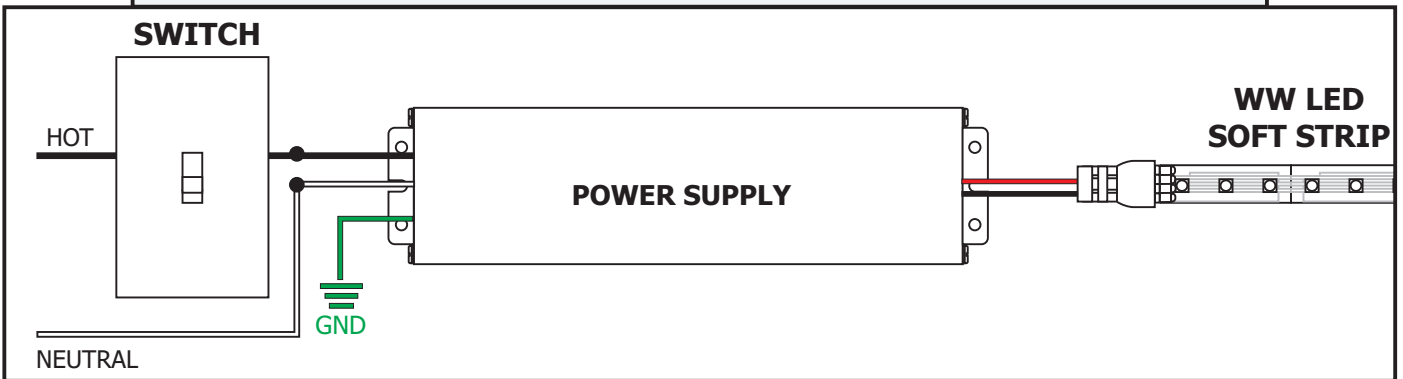

Using LED Power Supply with RGB Soft Strip & CDP or CTP Controll

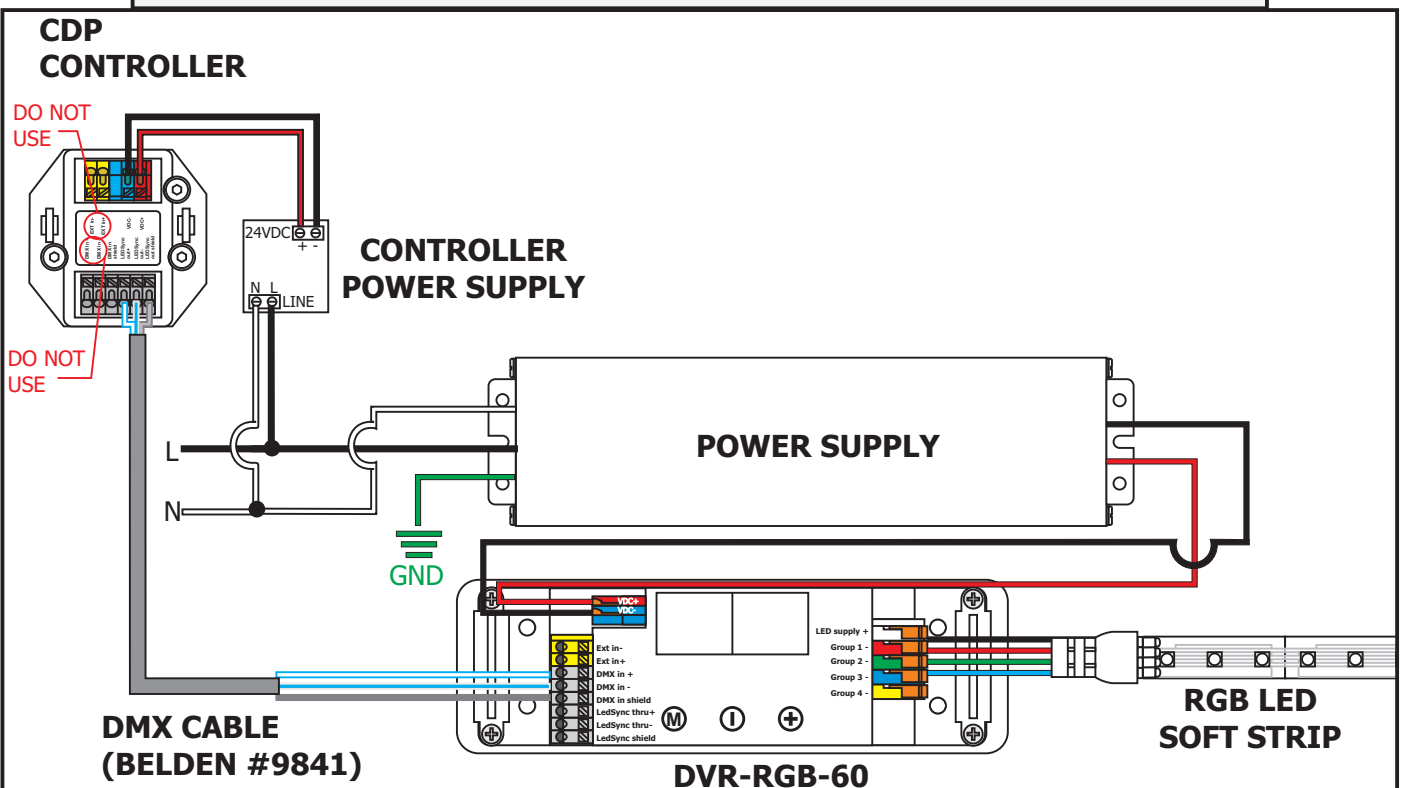

Selecting Modes

Configure your CDP by setting the DIP switches on the front:



COLOR MODE



CHASE MODE

NOTE: The DIP switches must remain accessible after installation. When making changes in the DIP switch settings, disconnect and reconnect the power supply to activate new settings.

Operating CDP

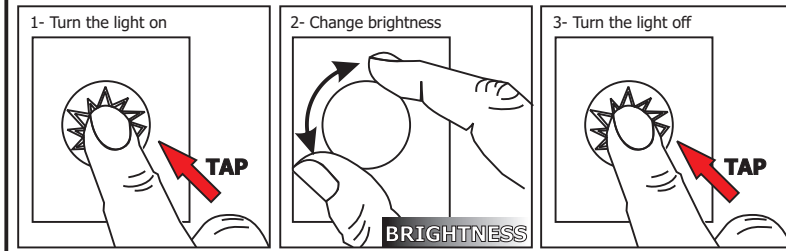

Advanced Operation for Color Mode

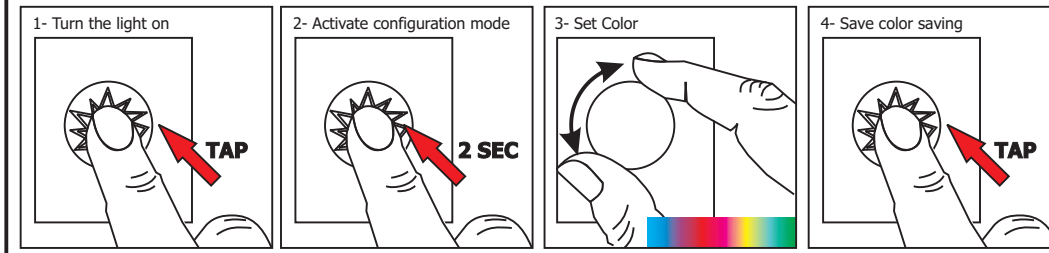

Advanced Operation for Chase Mode

