

Installation Instructions for Rebel 1", 6", & 12"

IMPORTANT SAFETY INSTRUCTIONS

To reduce the risk of fire, electrical shock, exposure to excessive UV radiation, or injury to persons:

- Use this fixture indoors only.
- Do not look directly at the lamp while the fixture is on.
- **RISK OF FIRE:** Use only the type of lamp and maximum wattage indicated in this instruction manual.
- Never cover the halogen lamp with anything other than a lamp shield provided by Edge Lighting and never place flammable material close to the fixture.
- Never turn the fixture on and off by connecting and disconnecting the halogen lamp.
- Do not touch the fixture head, shade or lamp shield while the fixture is on. These surfaces may be **VERY HOT**.
- Do not touch lamp at anytime. Use a soft cloth. Oil from skin may damage lamp.
- It is normal for a new halogen lamp to produce minor smoke when first turned on.
- Do not operate the luminaire with a missing or damaged shield.
- Turn power off and allow to cool before replacing lamp.

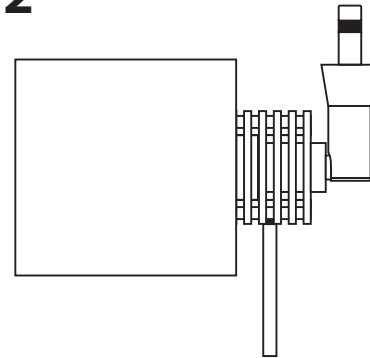

IMPORTANT INFORMATION

- This product is ETL listed for indoor dry locations.
- This product is not restricted to certain height installation. It is approved to be used at any height above the floor.
- Applicable accessories are Hexcell Louver and Glass Lenses.

SAVE THESE INSTRUCTIONS!

Install the Lamp

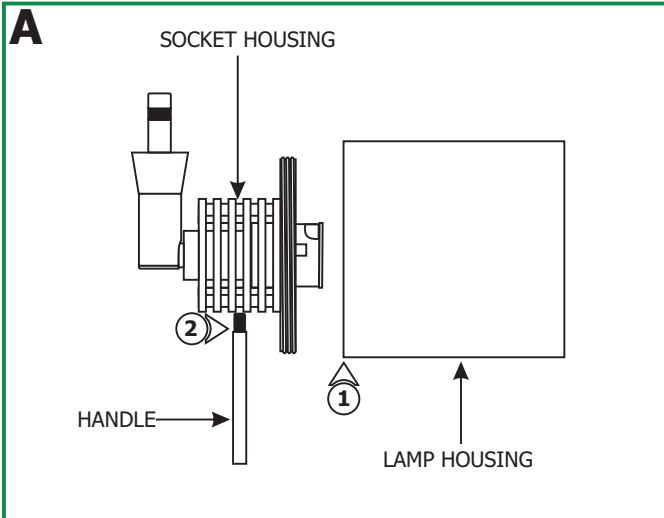

CAUTION: To reduce risk of a burn or electrical shock during lamping, disconnect the power to the fixture.

- 1:** Unscrew and remove the lamp housing from the socket housing.
- 2:** Screw the handle to the bottom of the socket housing.

Use **MAX 50** Watt, Type MR16 Front Glass Cover Halogen Lamp.



- 3:** Push the lamp pins completely into the socket holes.
- 4:** Place maximum of two optional glass lenses or a combination of hexcell louver and glass lens into the lamp housing.
- 5:** Replace and screw the lamp housing to the socket housing.

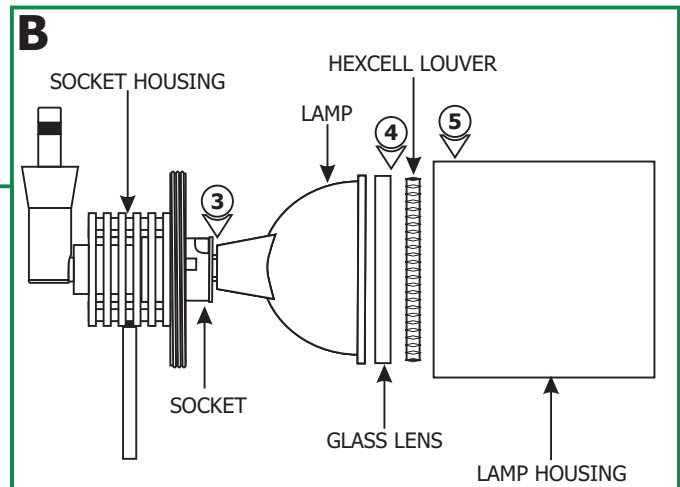

Install the Fixture to Monorail Connector (MC-FJ-_)

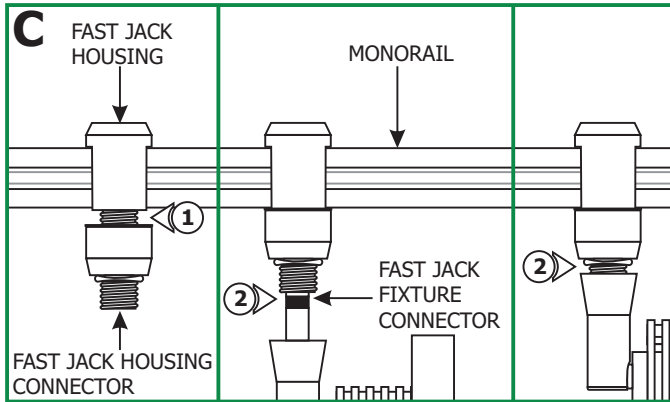

- 1: Place the Fast Jack housing onto the Monorail and use fingers to tighten the Fast Jack housing connector to the Fast Jack housing. **Make sure that the Fast Jack housing connector is not cross threaded.**
- 2: Use fingers to tighten the Fast Jack fixture connector into the Fast Jack housing connector.

Install the Fixture to Monorail 2 Circuit Connector (M2C-FJ-_)

- 1: Place the Fast Jack housing onto the Monorail 2 Circuit and use finger to tighten the Fast Jack housing connector to the Fast Jack housing. **Make sure that the Fast Jack housing connector is not cross threaded.**
- 2: Use fingers to tighten the Fast Jack fixture connector into the Fast Jack housing connector.

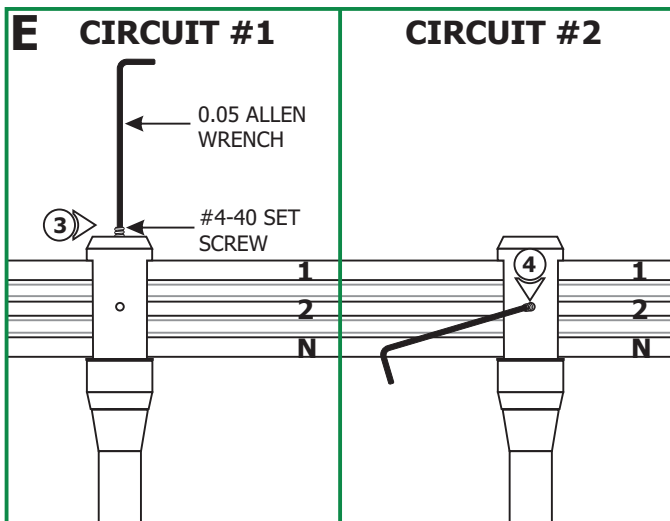
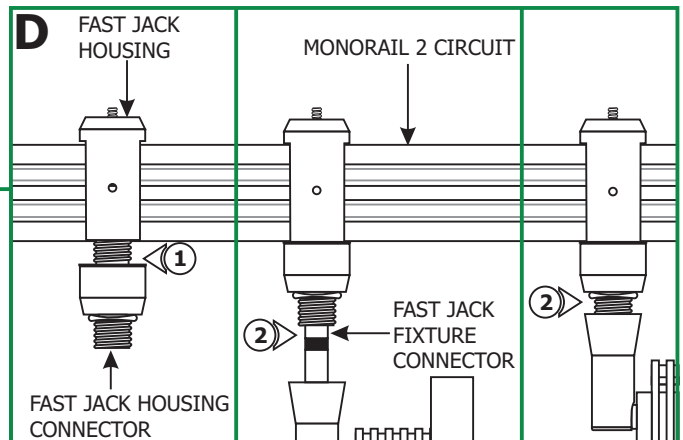

- 3: To power the fixture from circuit #1, top and bottom (neutral) rails, tighten the #4-40 set screw on top of the housing with the 0.05 Allen wrench. **Make sure this set screw connection is very tight.**
- 4: To power the fixture from circuit #2, middle and bottom (neutral) rails, remove the #4-40 set screw from top of the housing and tighten it into the side threaded hole with the 0.05 Allen wrench. **Make sure this set screw connection is very tight.**

NOTE: To avoid shorting the system, do not use more than one set screw to select a circuit on the Monorail 2 Circuit connector.

NOTE: Do not load either circuit over the maximum system rating.

Install the Fixture to Fast Jack Canopy (FJP-2SQ-_, FJP-4SQ-_, FJP-4RD-_)

- 1: Use fingers to tighten the Fast Jack fixture connector into the Fast Jack canopy connector.

