

Installation Instructions for Step Halogen Kit

IMPORTANT SAFETY INSTRUCTIONS

To reduce the risk of fire, electrical shock, exposure to excessive UV radiation, or injury to persons:

- Use this fixture indoors only.
- Do not look directly at the lamp while the fixture is on.
- **RISK OF FIRE:** Use only the type of lamp and maximum wattage indicated in this instruction manual.
- Never cover the halogen lamp with anything other than a lamp shield provided by Edge Lighting and never place flammable material close to the fixture.
- Never turn the fixture on and off by connecting and disconnecting the halogen lamp.
- Do not touch the fixture head, shade or lamp shield while the fixture is on. These surfaces may be **VERY HOT**.
- Do not touch lamp at anytime. Use a soft cloth instead as oil from skin may damage lamp.
- It is normal for a new halogen lamp to produce minor smoke when first turned on.
- Turn power off and allow to cool before replacing lamp.

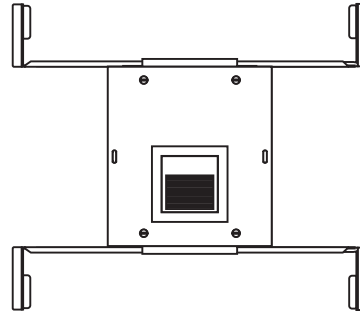

IMPORTANT INFORMATION

- This product is ETL listed for indoor dry locations.
- This product is wall mounted only.
- This product can be dimmed with a electronic low voltage dimmer.

SAVE THESE INSTRUCTIONS!

Install the Step Housing

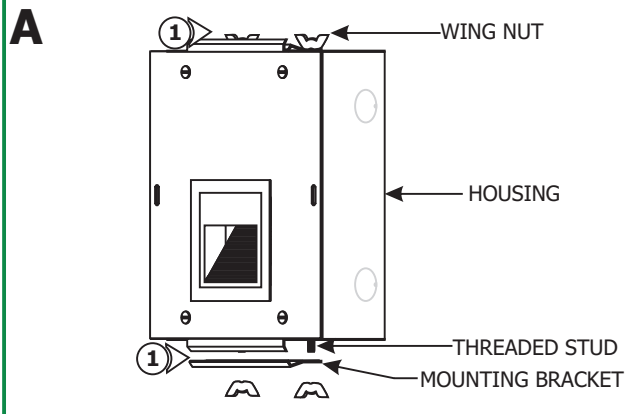

1: Loosen the two top and bottom wing nuts on the housing to remove the two mounting brackets.

2: Mount one adjustable mounting bar to the top of the housing by sliding it completely under the housing lip.

3: Replace the mounting bracket onto the threaded studs so that the flange faces the adjustable mounting bar. Tighten the wing nuts to secure the adjustable mounting bar in place.

4: Repeat steps 2 and 3 for the bottom of the housing.

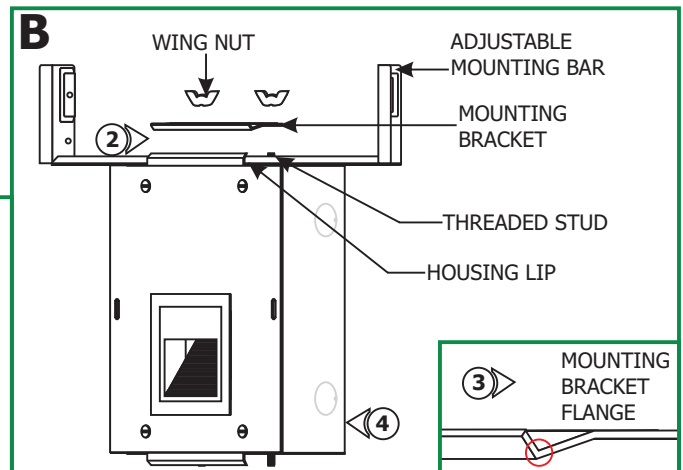

LOW VOLTAGE WIRE SIZE CHART

TRANSFORMER WATTAGE	WIRE SIZE FOR 10 FT	WIRE SIZE FOR 11-15 FT	WIRE SIZE FOR 16-25 FT	WIRE SIZE FOR 26-40 FT
75 WATT	#14 GA	#12 GA	#10 GA	#8 GA

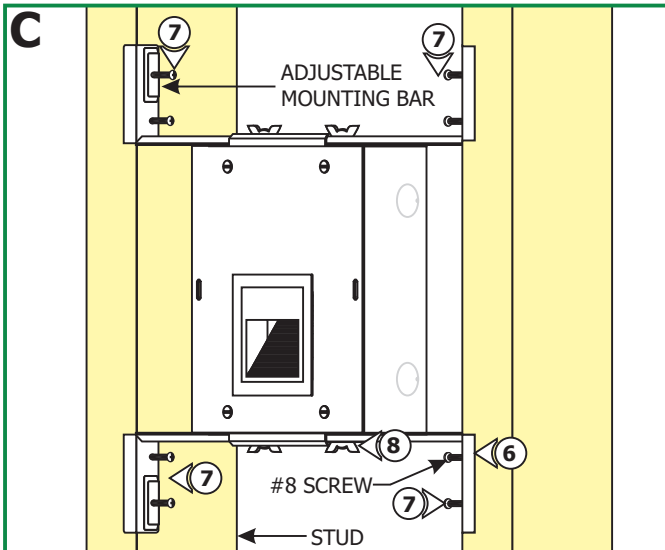

NOTE: The adjustable mounting bars mount to studs that are spaced 16" to 24" apart.

- 5:** Select the location between the two studs for the housing to be mounted.
- 6:** Place the adjustable mounting bars between the studs.
- 7:** Make sure the lips on the adjustable mounting bars are against the studs. Secure the adjustable bars to the studs with the provided eight #8 screws.
- 8:** Slide the housing to desired position. If necessary loosen the wing nuts to ease the sliding. After the desired position is achieved tighten all the wing nuts.

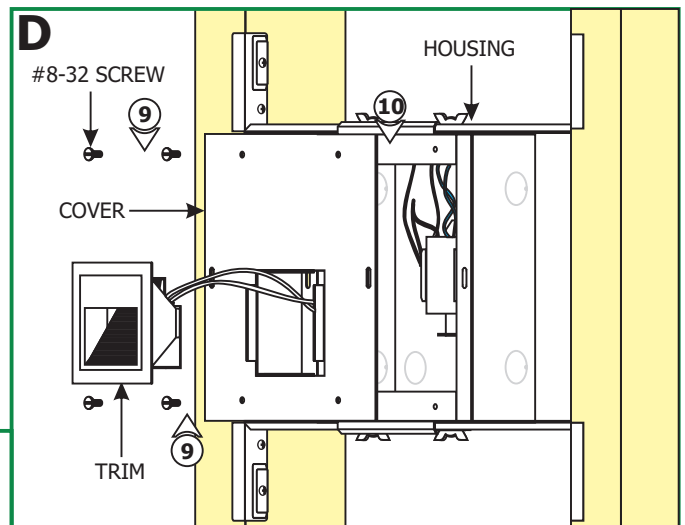

- 9:** Loosen the four #8-32 screws on the front of the housing.
- 10:** Remove the trim and cover from the housing.

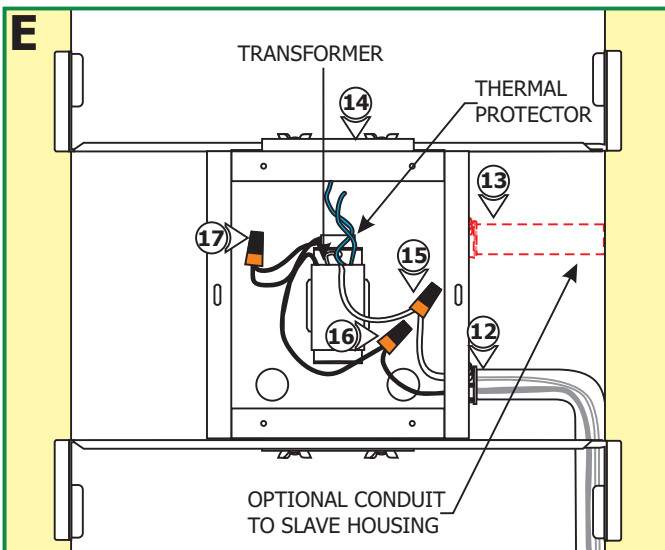

- 11:** Remove a knock out to install the power line conduit.
- 12:** Install the conduit and run the power line wires to the housing.
- 13: (OPTIONAL)**-If using slave housings (Maximum 5 Slave Housings), repeat step 1 through 10 on pages 1 and 2 for each slave housing; run conduits for the low voltage wires in sequence from the master housing and slave housing to the adjacent slave housing .

NOTE: Maximum 5 Slave step kits can be powered from a master step kit.

- 14:** Make sure that the housing is grounded in accordance with local electrical codes.
- 15:** Connect the transformer white wire to the power line neutral wire with a wire nut.
- 16:** Connect the black thermal protector wire to the power line hot wire with a wire nut.
- 17:** The transformer black wire is connected by default to the other wire of the thermal protector.
- 18:** If using slave housings, then follow the "Slave Step Kit Wiring" steps; otherwise follow "Install the Drywall, Trim & Lamp" steps on page 4.

Slave Step Kit Wiring

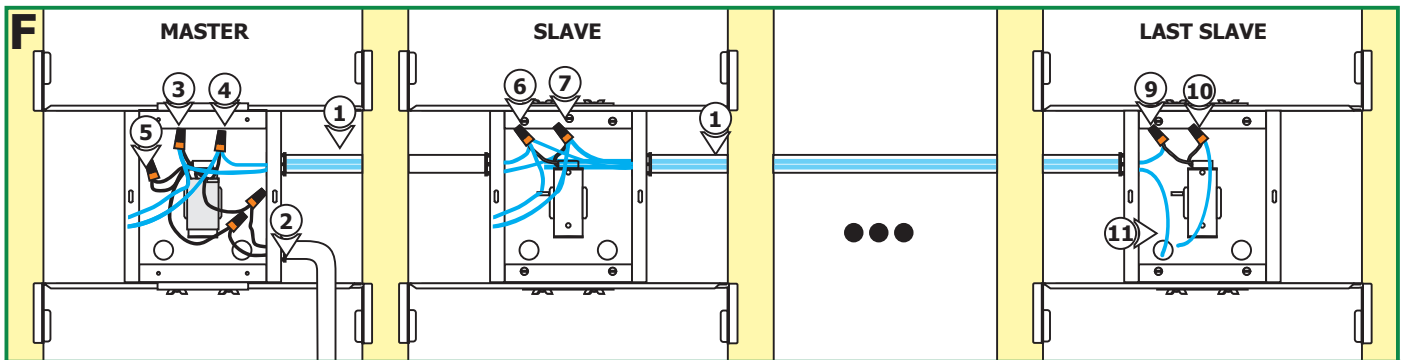
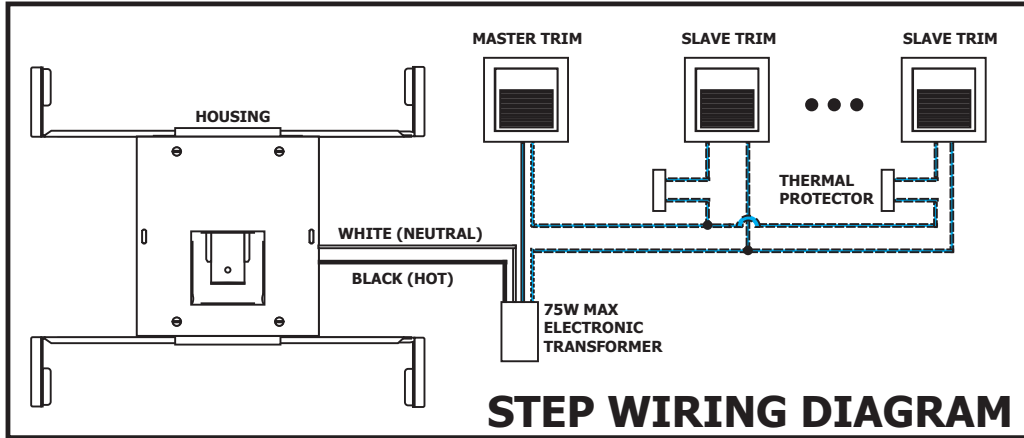

- 1:** Run the proper low voltage wires to each housing by referring to the "Low Voltage Wire Size Chart" on page 1. The distances are from the master housing to each slave housing. Refer to the wiring diagram above before proceeding with the steps below.
- 2:** Make sure the power to the transformer line voltage wires are off.
- 3:** Starting with the master housing, connect one transformer wire to one low voltage wire going to adjacent slave housing and to a 1 foot long low voltage pigtail wire with a wire nut.
- 4:** Connect the other transformer wire to the other low voltage wire going to the adjacent slave housing and another 1 foot long low voltage pigtail wire with a wire nut.
- 5:** Continuing with the adjacent slave housing, connect one of the low voltage wires coming from the preceding housing to one of the thermal protector wire with a wire nut.
- 6:** Connect the other thermal protector wire to one of the low voltage wires going to the next slave housing and to a 1 foot long low voltage pigtail wire with a wire nut.
- 7:** Connect the other low voltage wire coming from the preceding housing to the low voltage wire going to the next housing and another 1 foot long low voltage pigtail wire.
- 8:** Repeat steps 4 through 6 for all other slave housing except the last one.
- 9:** For the last slave housing, connect one low voltage wire coming from the preceding housing to one of the thermal protector with a wire nut.
- 10:** Connect the other thermal protector wire to a 1 foot long low voltage pigtail wire with a wire nut.
- 11:** Make sure the other low voltage wire coming from preceding housing extends 1 foot out of the slave housing.

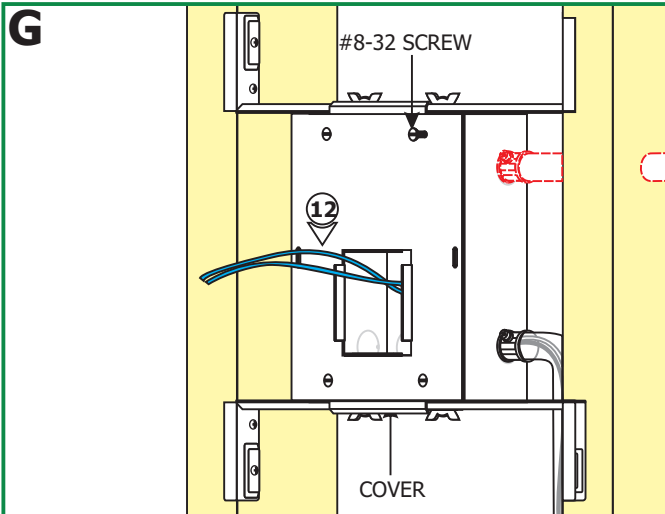

12: Feed the pigtail wires through the cover hole and mount to cover to the housing with the four #8-32 screws.

13: Repeat step 12 for the remaining housings.

1: Mark 3" square(s) on drywall where the housing opening is (are) located.

2: Cut out the marked square(s) and install the drywall.

Install Drywall, Trim & Lamp

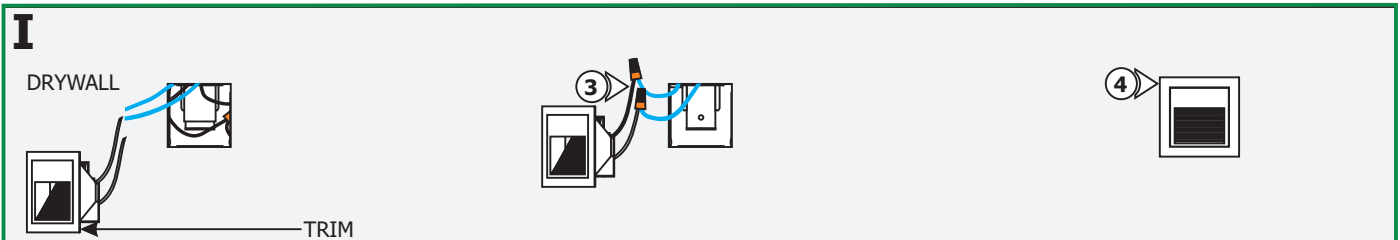
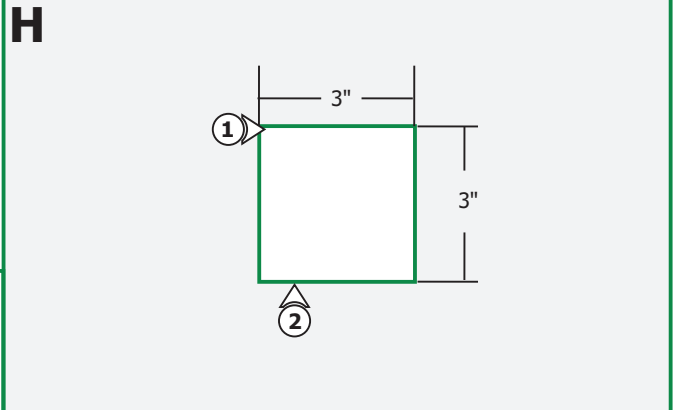

3: After installing drywall and finishing it, connect each wire coming out of the housing opening to one trim wire with a wire nut.

4: Place all wires inside the housing and gently push the trim into the housing opening by squeezing the side springs.

5: (Optional) - If slave housings are used, then repeat steps 3 and 4 for all slave housings.

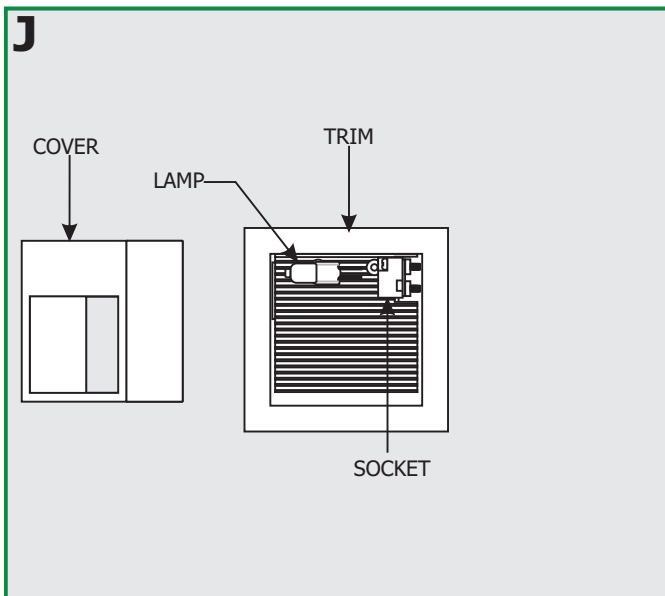

CAUTION: To reduce risk of a burn or electrical shock during lamping, disconnect the power to the fixture.

NOTE: Use only fingers and a soft cloth to install the lamps.

Use **MAX 10** Watt Bi-Pin Halogen Lamp For Each Socket.

6: Pull the trim cover off to expose the socket.

7: Push the lamp pins completely into the socket holes.

8: Replace the cover to the trim.

9: (Optional) - If slave housing are used, repeat steps 6 through 8 for all the housings.