

Installation Instructions for Fast Jack Vase Round and Square

IMPORTANT SAFETY INSTRUCTIONS

- Use this fixture indoors only.
- This product can be dimmed with a standard low-voltage electronic dimmer.
- This product must be installed by a qualified electrician.
- Before beginning any electrical work, ensure that power to the junction box is turned OFF.

SAVE THESE INSTRUCTIONS!

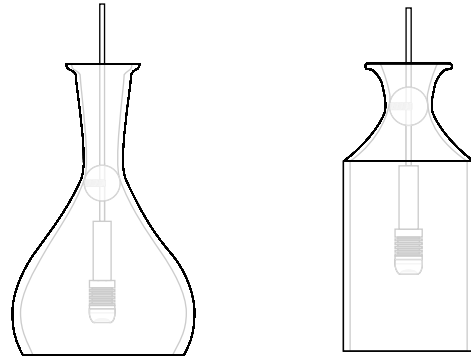

Install the Lamp

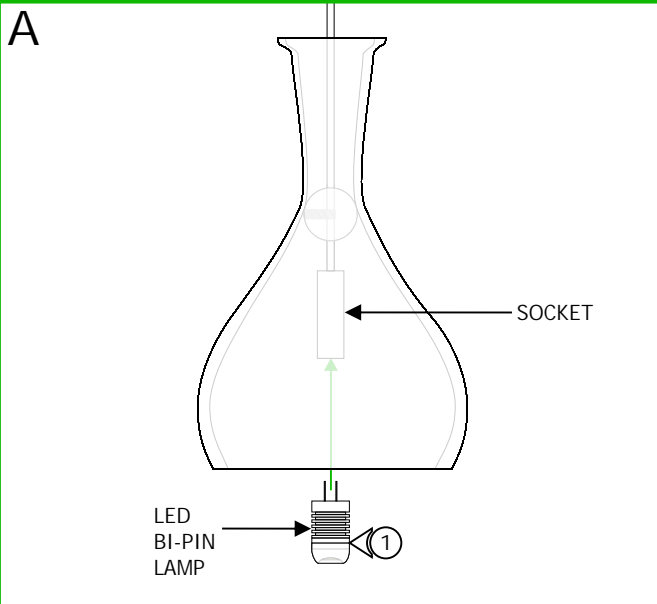

NOTE: Use MAXIMUM 3 Watt 12 VAC LED Bi-pin lamp.

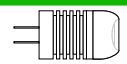

- 1: Push the LED lamp pins completely into the socket holes.

Adjust the Fixture Height

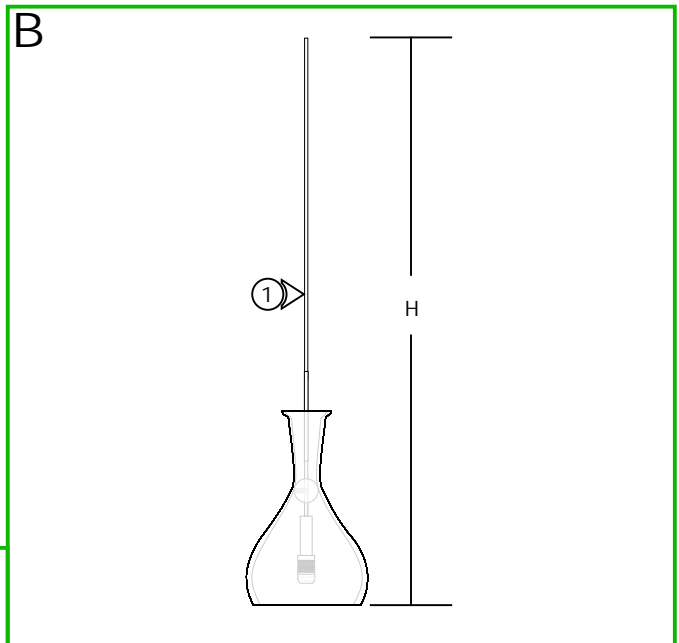

- 1: Cut the coaxial cable to the desired height (H) with a sharp cutter. The overall fixture height is measured from the bottom of the glass shade to the end of the coaxial cable.

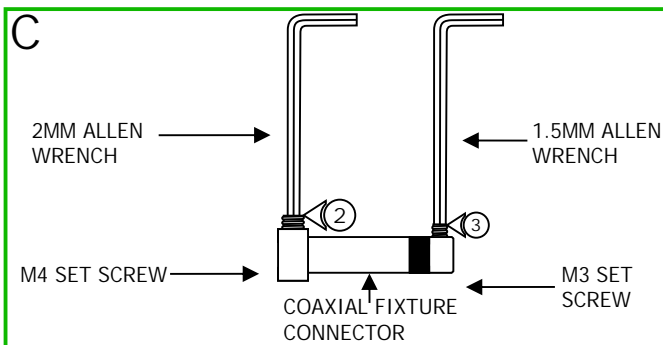

- 2: Loosen the M4 set screw on base of the coaxial fixture connector with the 2mm Allen wrench provided. Do not remove this set screw.
- 3: Remove the M3 set screw on tip of the connector with the 1.5mm Allen wrench provided.

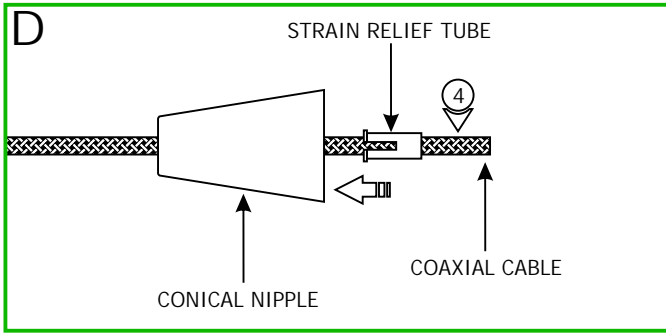

4: Feed the coaxial cable through the conical nipple and flared side of the strain relief tube. Slide the conical nipple and strain relief tube down the coaxial cable.

5: Feed the coaxial cable into the coaxial fixture connector. The coaxial cable will come to a stop point.

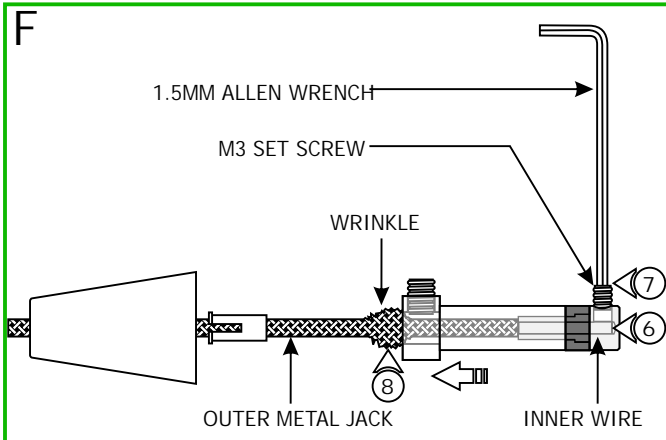
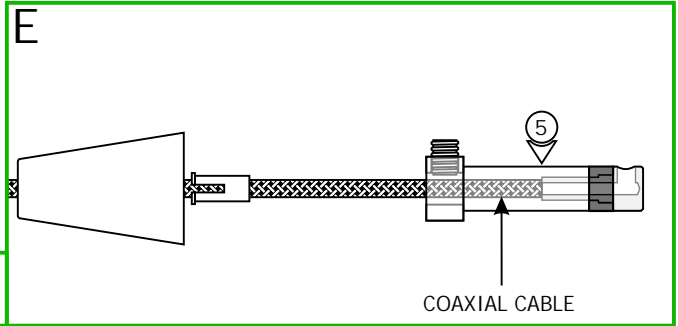

6: Keep feeding the coaxial cable in until the inner wire is visible in the screw hole of the fixture connector tip. The outer metal jacket will start to wrinkle.

7: Hold the fixture connector in place. Replace and tighten the M3 set screw on fixture connector tip with the 1.5mm Allen wrench.

8: Pull down the outer metal jacket to smooth the wrinkles.

9: Push the strain relief tube completely into the coaxial fixture connector. Make sure the slot on the strain relief tube is not inline with the M4 set screw.

10: Tighten the M4 set screw with the 2mm Allen wrench.

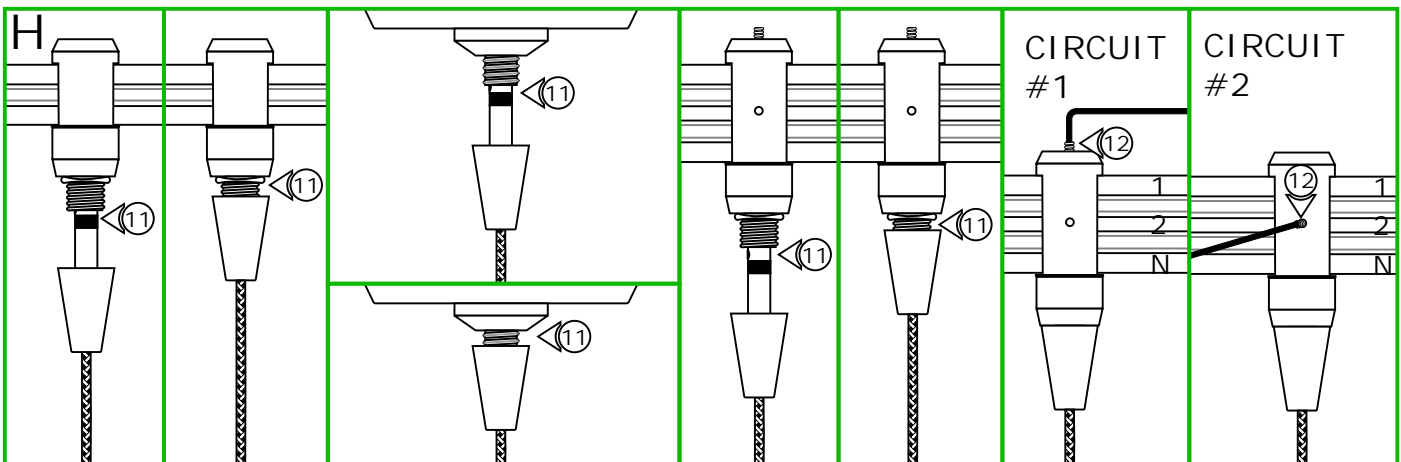
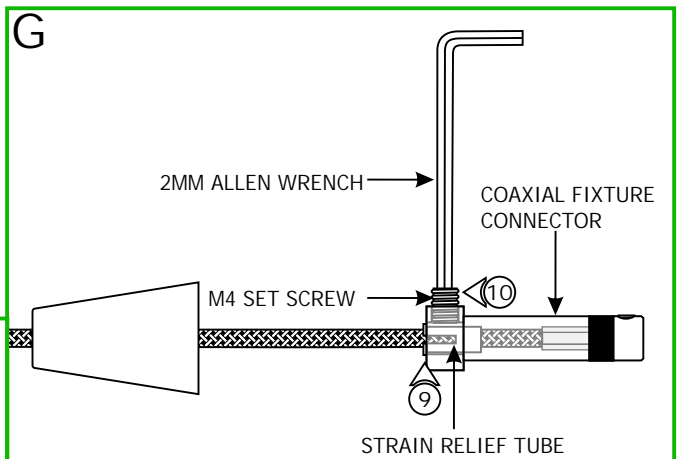

11: Use fingers to tighten the Fast Jack fixture connector into the Fast Jack system connector (Monorail, Monorail 2 Circuit, or canopy connector - Refer to the instructions provided with the system connector or canopy).

12: Refer to the instructions provided with the Monorail 2 Circuit fixture connector to choose Circuit #1 or Circuit #2.