

IMPORTANT INFORMATION

- This instruction shows a typical installation.
- It is recommended that a qualified electrician install this product.

SAVE THESE INSTRUCTIONS!



Install the Junction Box

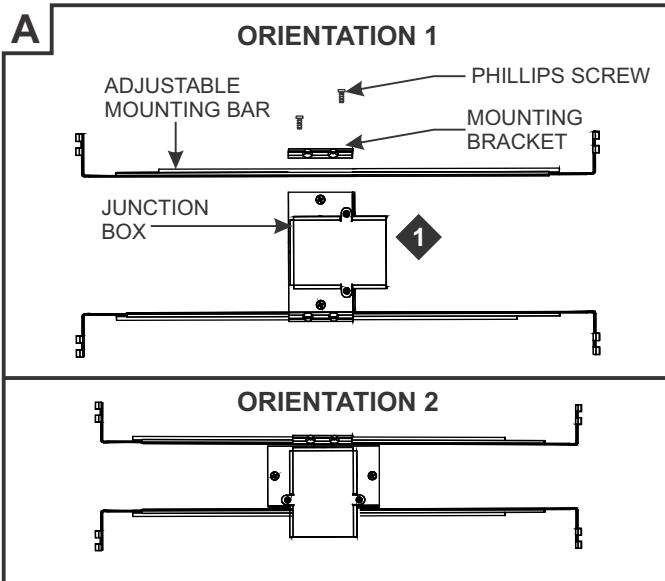

1: Mount each adjustable mounting bar to one side of the junction box (mounts to any side of the housing depending on the orientation of the channel) and secure them with the mounting brackets and two Phillips screws provided.

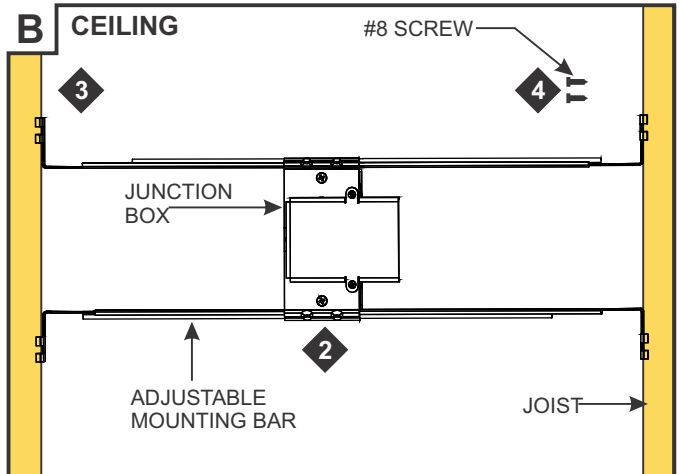

NOTE: The adjustable mounting bars mount to studs that are spaced 14.5" to 24" apart.

- 2:** Select the location between the two ceiling joists for the junction box to be mounted.
- 3:** Place the adjustable mounting bars between the joists.
- 4:** Make sure the lips on the adjustable mounting bars are against the joists. Secure the adjustable bars to the joists with the eight #8 screws.

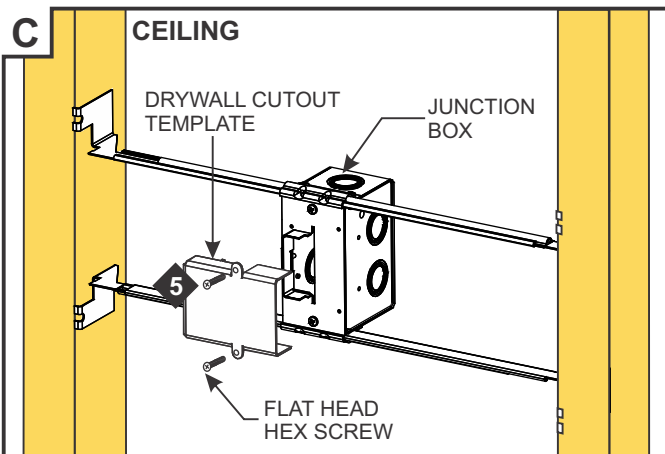

5: Remove the two hex socket flat head screws to pull the drywall cutout template completely off the junction box face. Discard the cutout template and screws.

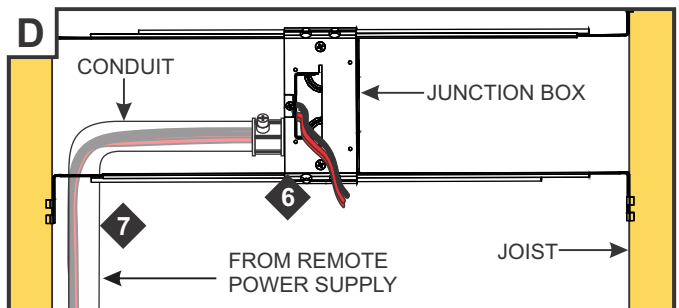

- 6:** Remove a knockout on the junction box to install conduit into the power feed electrical box.
- 7:** Install the conduit and run the low voltage 24V DC power wires.

NOTE: Maximum 12ft of Reveal Wall Wash can be powered from one junction box.

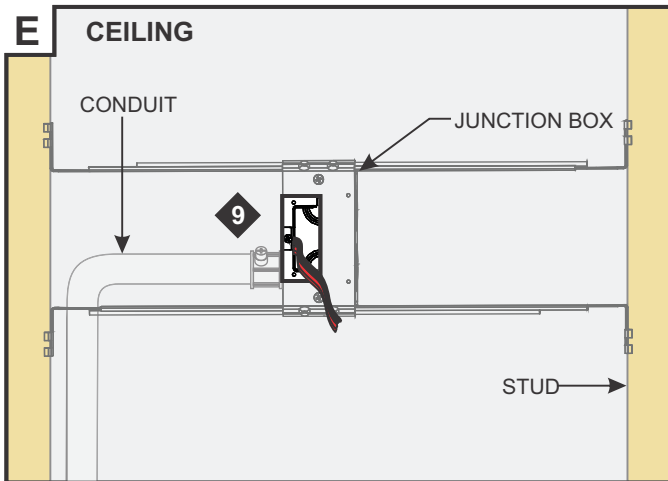

8: Mark the junction box opening on the drywall and cut out.

9: Install the drywall.

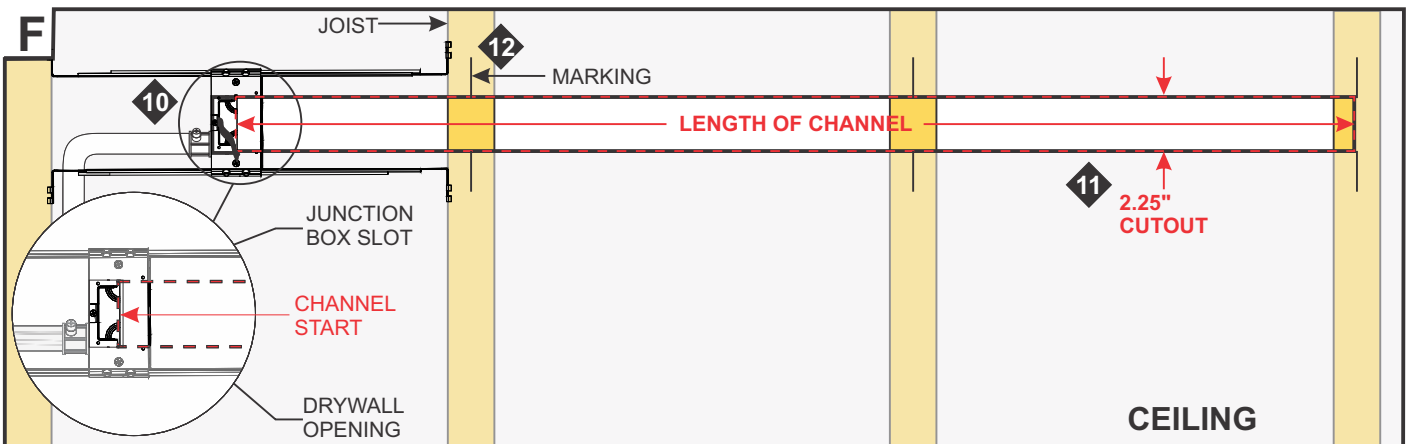

10: Using the drywall opening as reference, mark 2.25" wide lines the complete length of the channel along the drywall.

11: Cut out the mark line on the drywall.

12: Mark the location of the joists to the drywall for future reference.

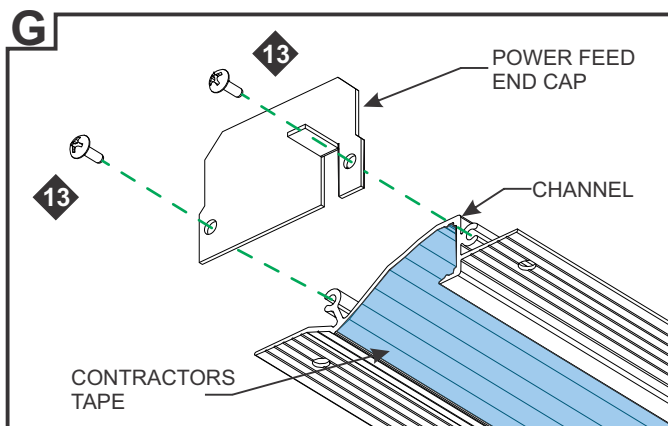

13: Install power feed end cap to the end of the channel that will be aligned with the junction box. Align the slot with the LED section of the channel.

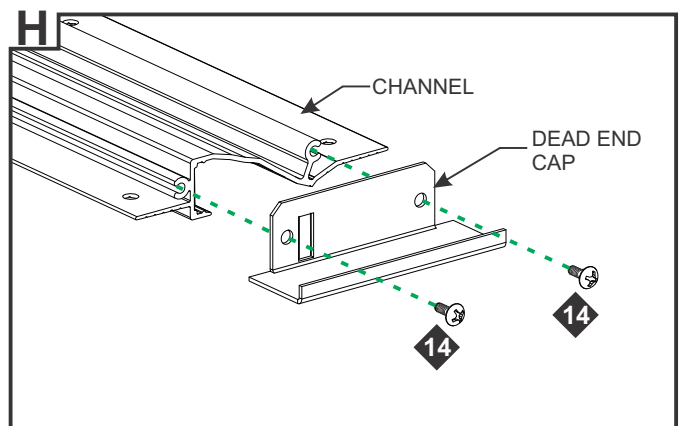

14: Install dead end cap to opposite end of channel length using supplied screws. Align the slot with the LED section of the channel.

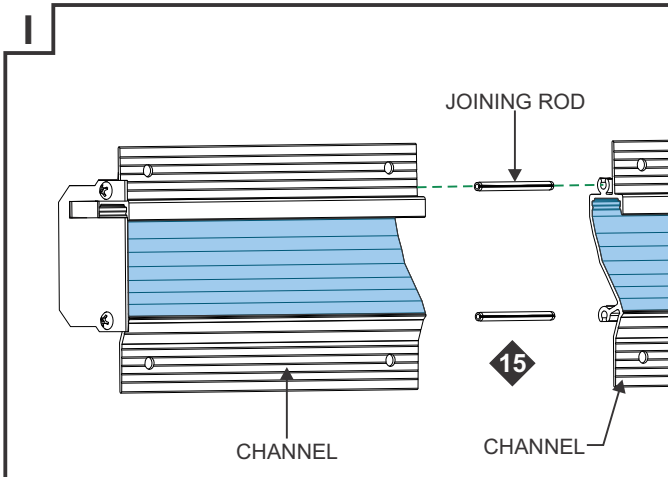

NOTE: It is recommended more than one person install the Reveal channel.

15: Insert the joining rods half way into each channel and slide channel pieces together.

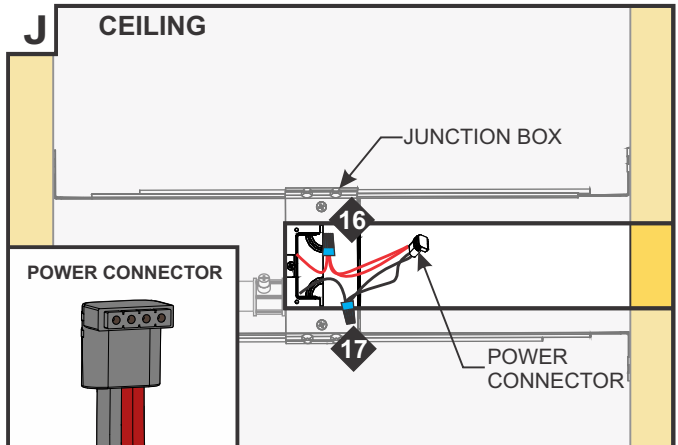

16: Connect the red power supply (24VDC+) wires to each red power connector wire with a wire nut.

17: Connect the black power supply (24VDC-) wires to each black power connector wire with a wire nut.

18: Place the wire nut connections inside junction box.

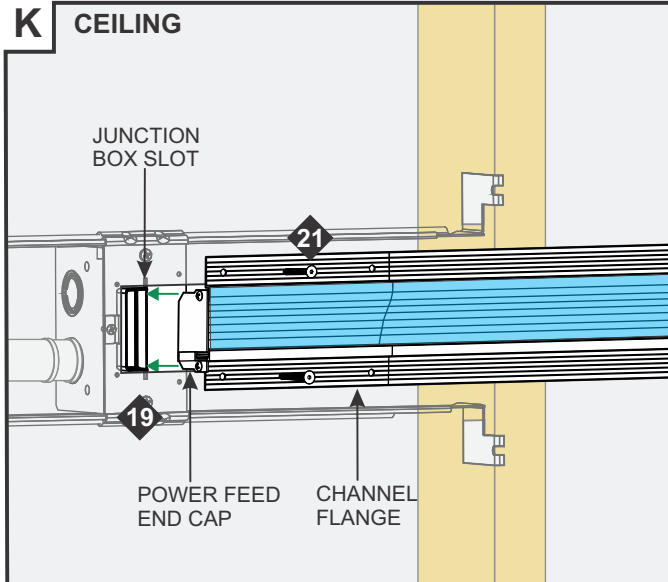

19: Align the power feed end caps into the junction box opening slots at both ends and push channel into the drywall cutout in the ceiling.

20: Make sure channel is aligned straight using a level.

21: Secure the channel using the two Phillips screws to the junction box flat head hex screws.

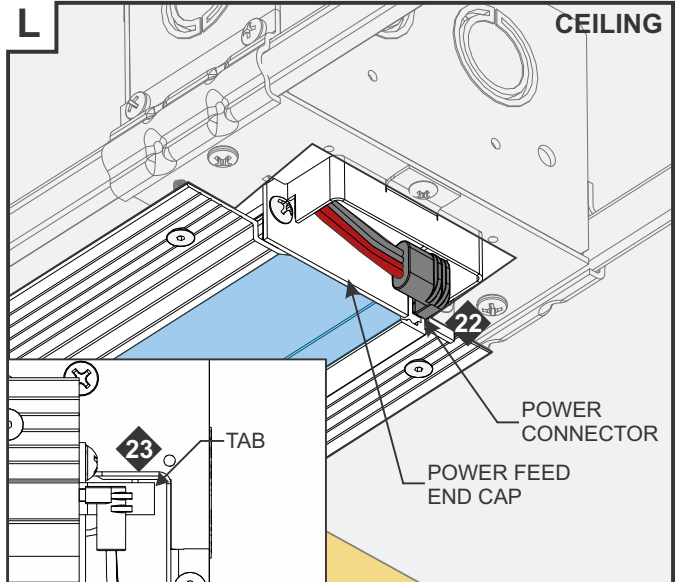

22: Place the power connectors into the slots in the power feed end caps

23: Use needle-nose pliers to bend up tab on power feed end cap to secure

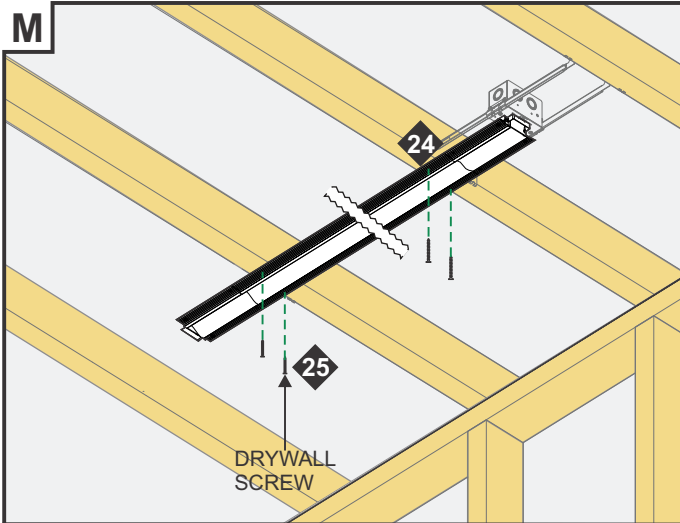

24: Drill and countersink holes to the channel at marked joist positions.

25: Secure channel to joists using #8 drywall screws.

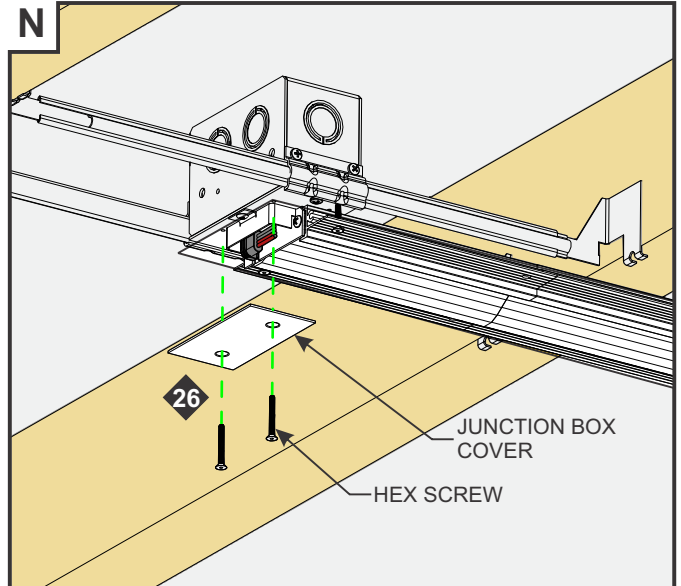

26: Secure the junction box cover to each junction box using the supplied hex screws.

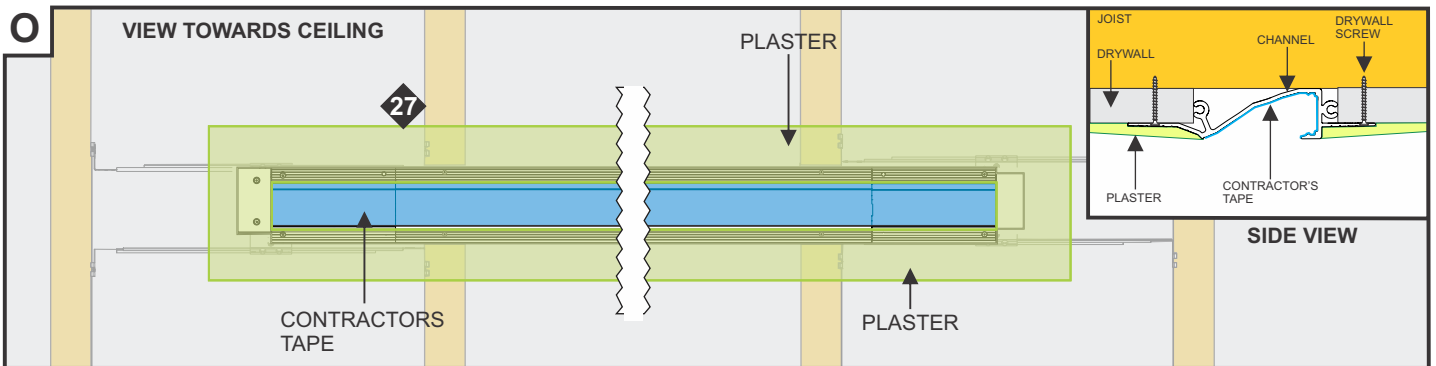

NOTE: Test LED strip before plaster work is started.

27: Plaster the channel flange edge to the ceiling and fill screw holes (highlighted in green). Sand and finish.

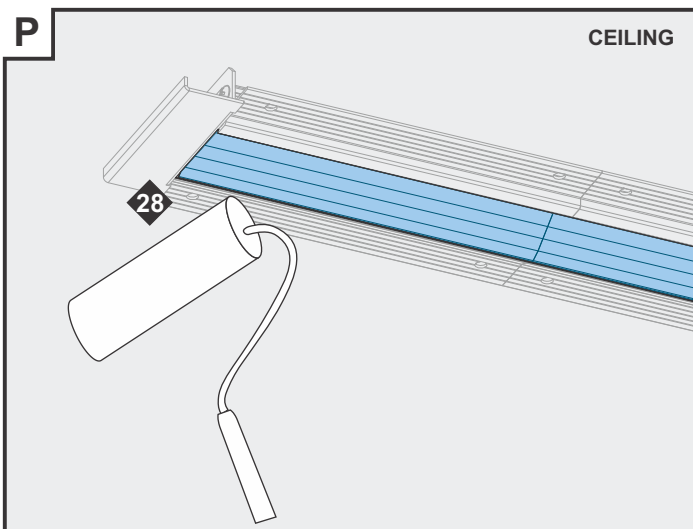

28: Paint the ceiling and channel lip

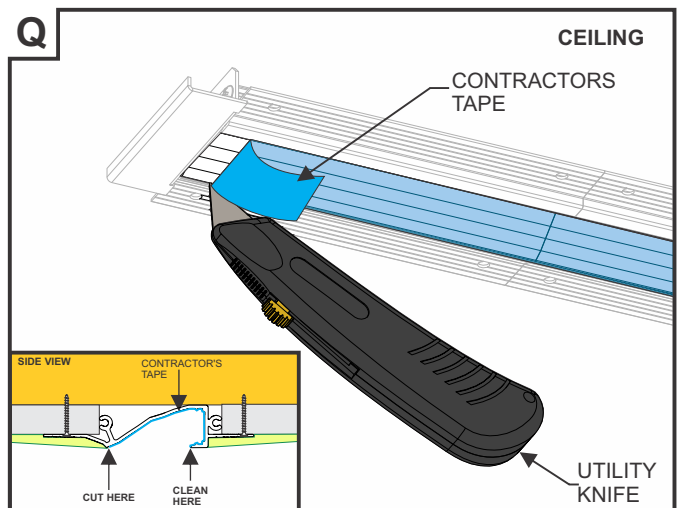

29: Use a utility knife to cut along the channel gutter while removing contractor's tape from the channel. This will avoid plaster and paint damage during tape removal.

30: Run utility knife blade along channel edge near area where LED strip will be installed to remove any excess paint.

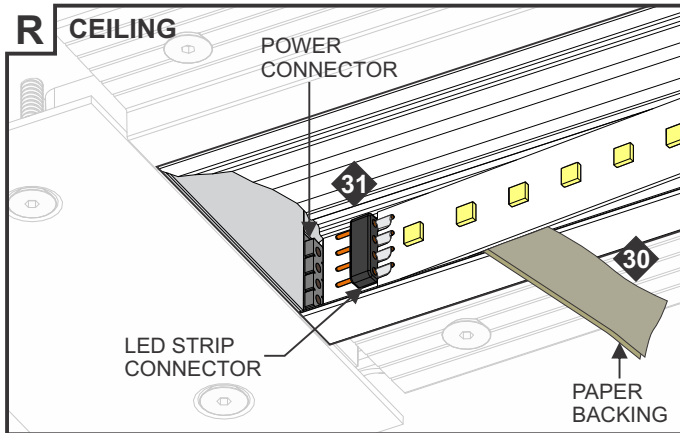

NOTE: Clean the channel area where the soft strip will be installed with alcohol prior to installation.

30: Begin removing the paper backing from the LED strip to expose the adhesive.

31: Insert the LED strip connector into the power connector.

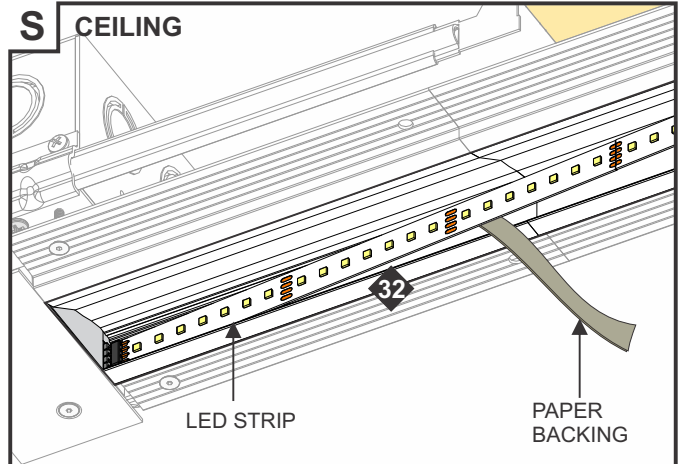

32: Lay the LED strip into the channel while removing the paper backing.

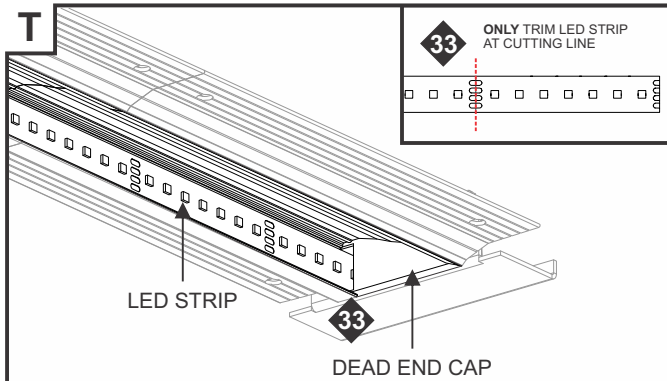

33: Trim excess LED strip ONLY at the indicated trim lines. Insert excess LED strip into dead end cap.

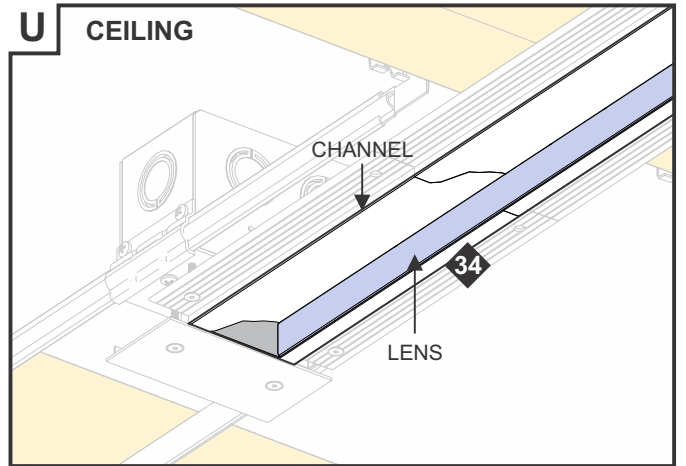

34: Install the lens (highlighted in blue) into the channel. Ensure the lens is fully seated.

GENERAL WIRING DIAGRAM

