

Installation Instructions for Twigg Tubular Lens 12 VAC

IMPORTANT INFORMATION

- This instruction shows a typical installation.
- This product is wall mount only.
- This product is dimmable with a low-voltage electronic dimmer.
- This product must be installed by a qualified electrician.
- The 1RE version mounts to the provided C-1RE-JBOX. The 4SQ version mounts to standard electrical box with plaster ring or octagon box.

SAVE THESE INSTRUCTIONS!

1RE



w/4" SQUARE CANOPY

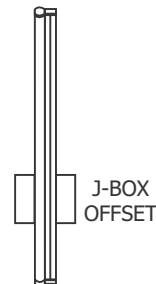
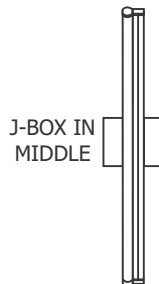

Section One: Steps For TW12-1RE Version

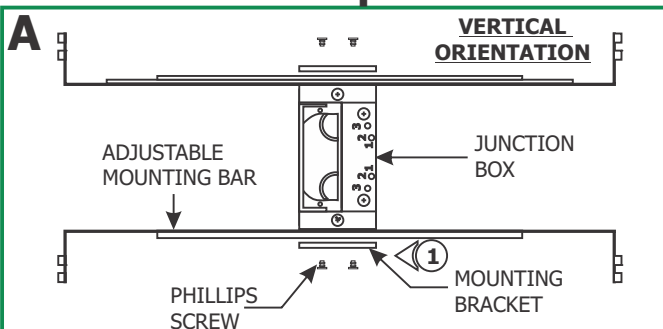

- 1:** Determine channel orientation. Mount each adjustable mounting bar to one side of the junction box and secure them with the provided mounting brackets and two Phillips screws.

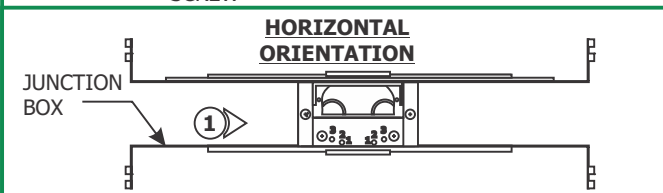

NOTE: The adjustable mounting bars mount to studs that are spaced 13" to 24" apart.

NOTE: Ensure the opening of the junction box is aligned with the center of the desired fixture location. If necessary, adjust the junction box location by loosening the screws and sliding the junction box to the proper location. Tighten the Phillips screws after adjusting.

- 2:** Select the location between the two studs for the junction box to be mounted.

- 3:** Place the adjustable mounting bars between the studs.

- 4:** Make sure the lips on the adjustable mounting bars are against the studs. Secure the adjustable bars to the studs with the eight #8 screws.

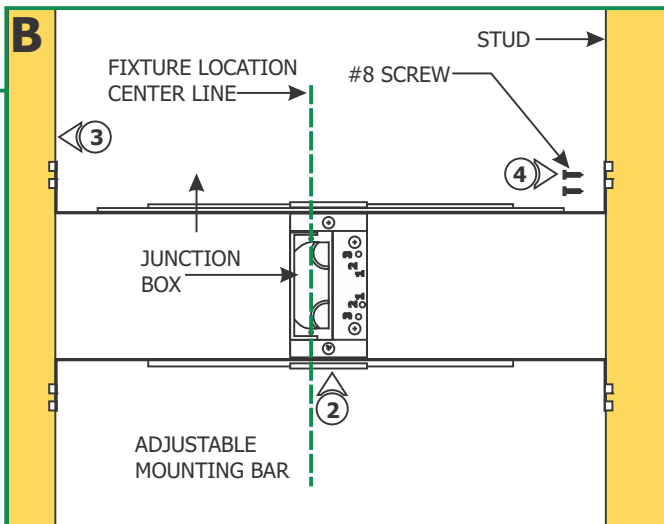

- 5:** Remove a knockout to install the power line conduit.

- 6:** Install the conduit and run the 120V power wires.

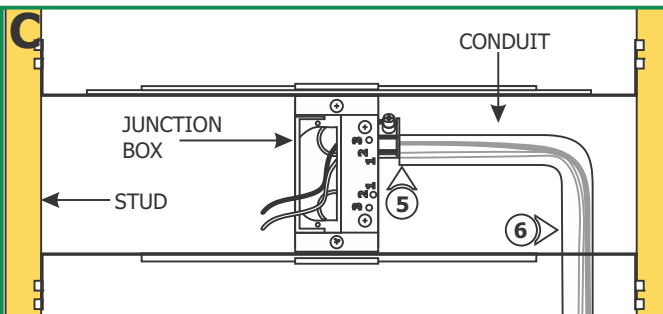

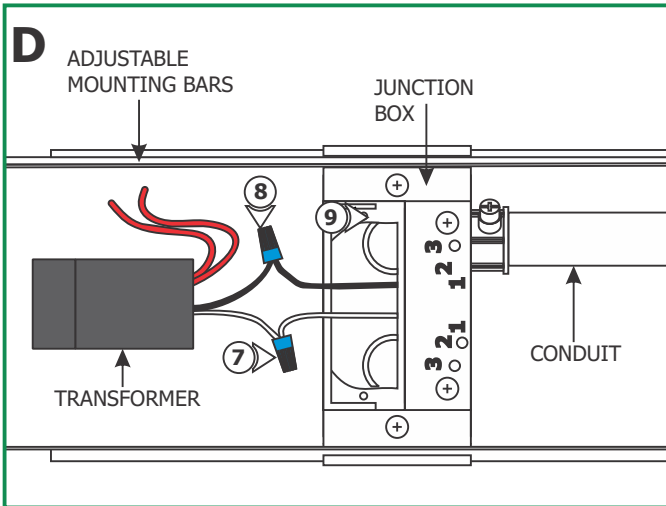

NOTE: If necessary junction box opening can be adjusted to two positions: Position 2 at 0.95" (recommended for this installation), or Position 3 at 1.05". Simply loosen screws and tighten to the corresponding position labeled on junction box. **POSITION ONE SHOULD NOT BE USED FOR THIS INSTALLATION** as it will not allow access to the LED transformer after installation.

- 7:** Connect the white transformer wire to the neutral power wire with a wire nut.
- 8:** Connect the black transformer wire to the hot power wire with a wire nut.
- 9:** Place the transformer and transformer wires inside the junction box.

- 10:** Mark a rectangle shape on drywall where the junction box opening will be located depending on selected position.
- 11:** Cut out the marked rectangle opening, using a "Dremel Multi-Max" with the "wood & drywall" cutting bit.
- 12:** Install & finish drywall.

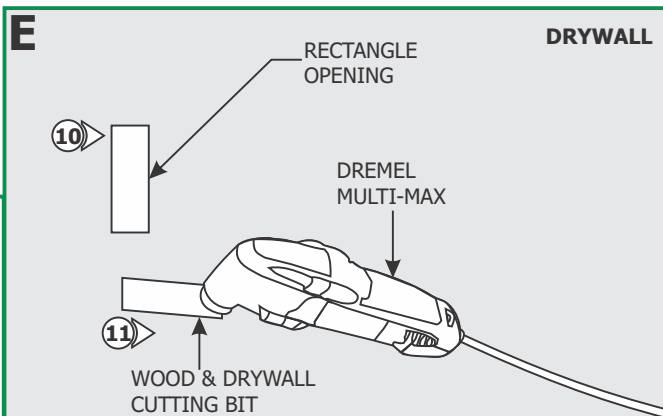

- 13:** Install the drywall and plaster around the junction box opening. Sand and then paint.
- 14:** **If necessary:** Use the Goof Plate if the junction box opening has a lot of imperfection/jagged edges. Install the provided goof plate (paint to match prior) with the two screws.
- 15:** Complete installation by following steps in Section Three.

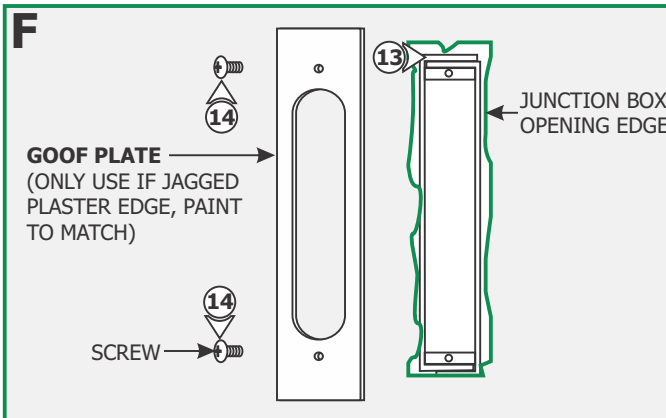

Section Two: Steps For TW12-4SQ Version

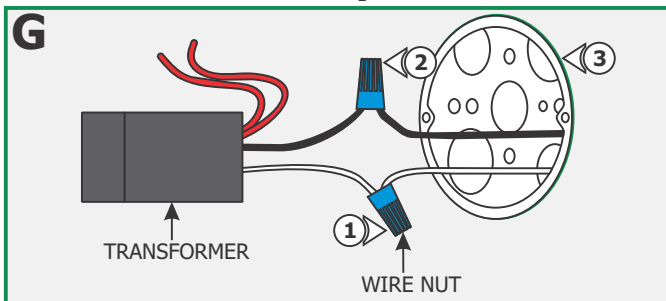

- 1:** Connect the white power supply wire to the neutral power wire with a wire nut.
- 2:** Connect the black power supply wire to the hot power wire with a wire nut.
- 3:** Place the power supply and wires inside the electrical box.

- 4:** Feed the transformer wires from the crossbar center hole and mount the crossbar to the electrical box holes with the two #8-32 screws provided.
- 5:** Complete installation by following steps in Section Three.

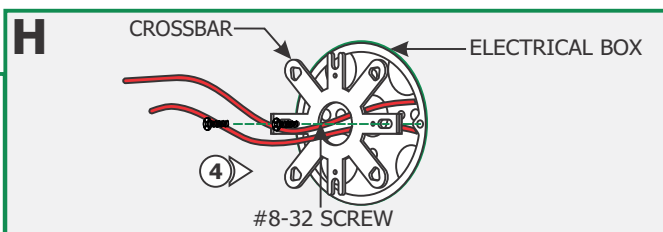

Section Three: Install Fixture For Both Versions

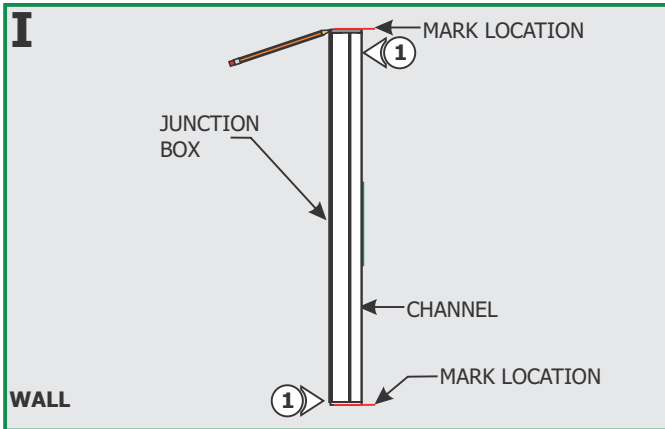

NOTE: It is recommended more than one person to assist in this installation.

NOTE: Fixture can be mounted in a horizontal or vertical position.

NOTE: The junction box does not need to be in middle of the channel (could be at either end) but needs to be aligned in the center of the channel.

- 1:** Align the channel to the junction box opening. Make markings to each end of the channel and also make a center line from end to end. **Note which side the wires are located to later install the locking clip to the opposing side.**

NOTE: TW12-T1-1RE shown for demonstration purposes

NOTE: Locking clip must be installed in the opposite direction of the fixture wire. Fixtures greater than 36" are provided with two locking clips.

NOTE: The junction box could be offset, but needs to be aligned to the center of the channel.

- 2:** From the two existing marks, make additional marks by following drawing H (a typical suggested location with measurements for the locking clip - longer runs contain two locking clips) to install the locking & mounting clips properly. Mounting clips must be installed every 20" from each other.

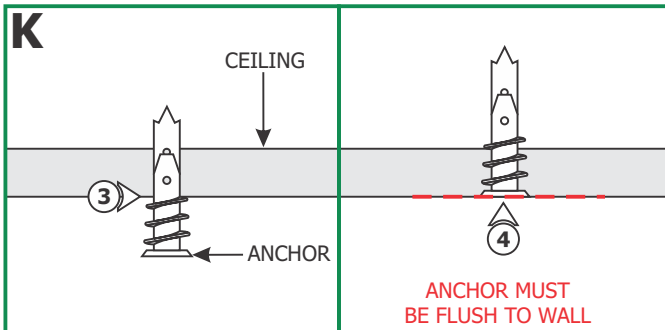
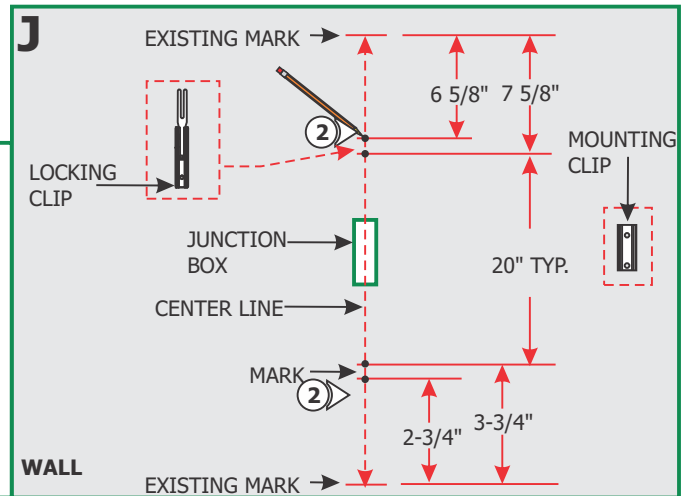

NOTE: Steps 3 and 4 are for drywall mounting. Omit these steps if mounting the clips to a wood surface directly.

- 3:** Tap the anchors onto the marked points up to the threaded portion with a hammer.

- 4:** Screw in the threaded portion of the anchors with a Phillips screwdriver.

- 5:** Secure the locking clip(s) & mounting clip(s) to the marked surface or anchors by passing the screws through the clip holes followed by the washers into the marked points or anchors. Locking clips mount onto mounting clips.

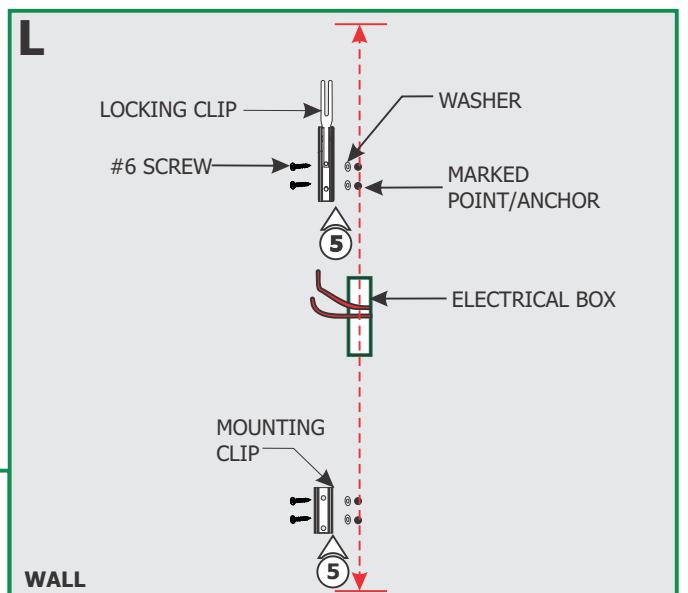

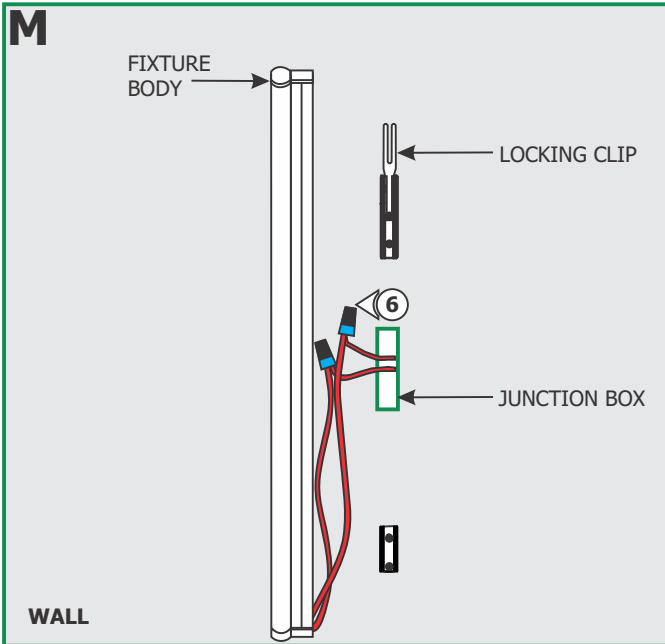

6: Connect each power supply wire to a fixture body wire with a wire nut.

7: Place the wires and wire nut connection inside the junction box.

8: Carefully snap fixture body onto the locking & mounting clip(s) then slide into receiving bracket to lock in place. Make sure not to nick the wires.

NOTE: If the receiving bracket interferes with the electrical box, then relocate the bracket by loosening the set screws and make the necessary adjustments.

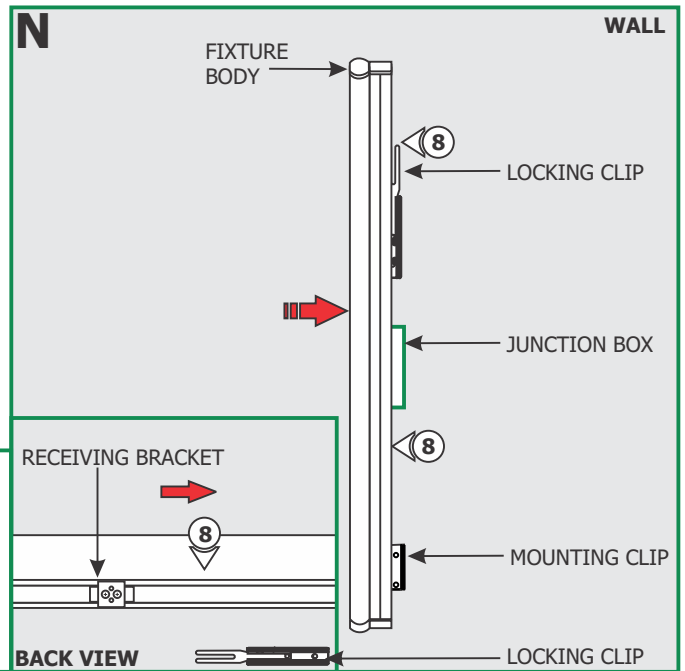

13 (OPTIONAL): For 4" Square Canopy installations, place each canopy piece against the crossbar and secure it to the electrical box holes with the provided #4-40 screws using the 1/16 Allen wrench.

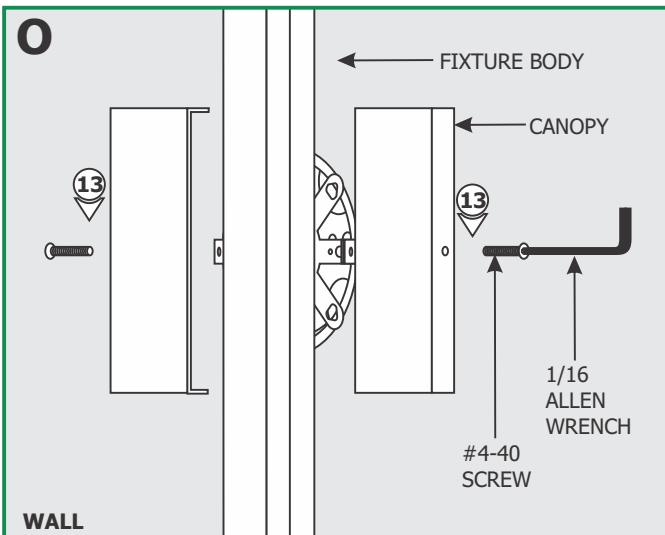

GENERAL WIRING DIAGRAM

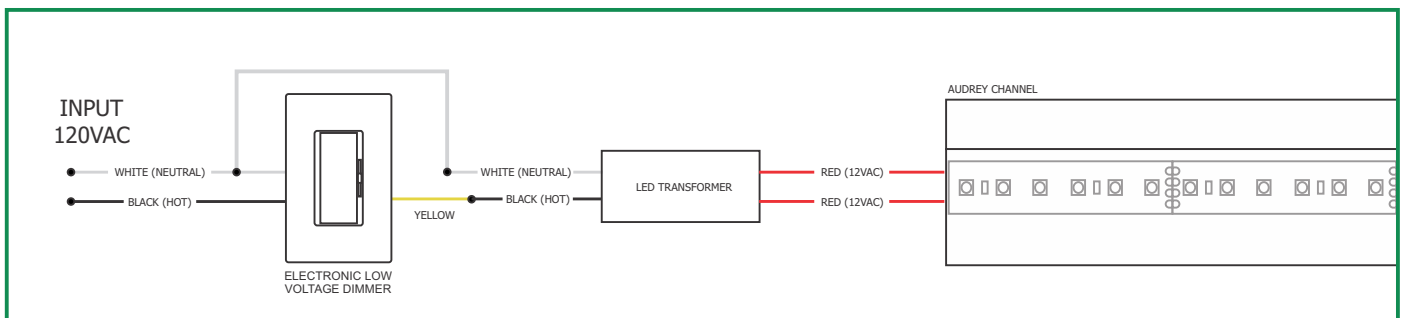

Installing Twiggy Fixture on Mirror

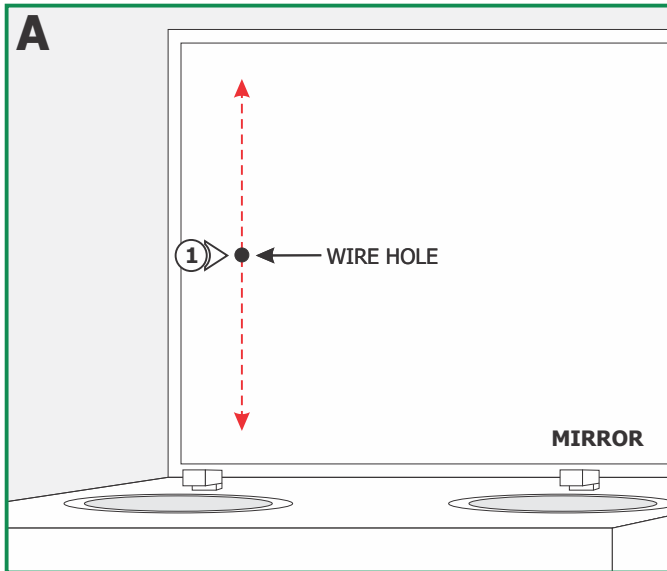

NOTE: It is recommended more than one person assist in this installation.

NOTE: To avoid damage to mirrors, ensure installation is completed by an experienced installer.

NOTE: Fixture can be mounted in a horizontal or vertical position.

NOTE: The junction box can be located anywhere along the length of the fixture but be aligned with the centerline of the channel.

1: Carefully drill a small hole in the mirror to pass low voltage wires through.

NOTE: Locking clip must be installed in the opposite direction of the fixture wire. Fixtures greater than 36" are provided with multiple locking clips.

2: Align and space mounting clips on mirror surface

3: Affix mounting clips to mirror using appropriate adhesive.

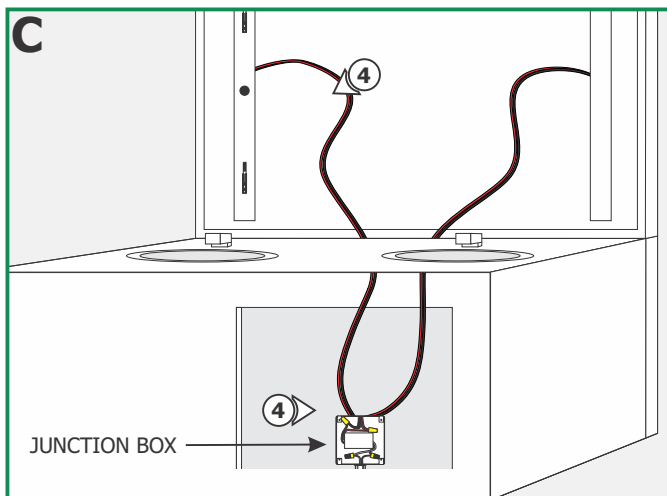
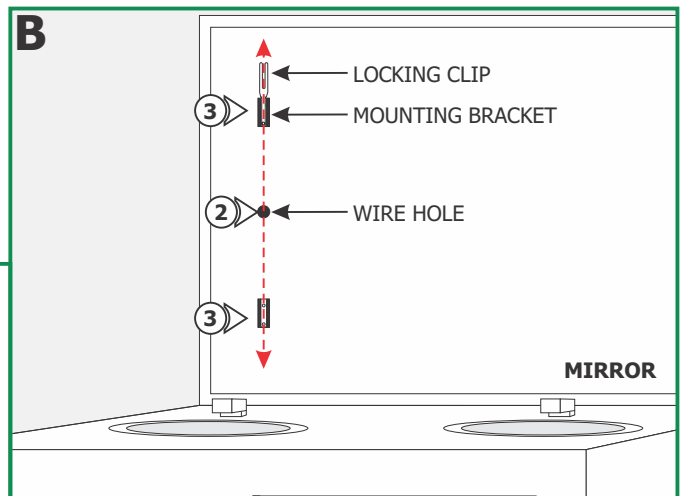

NOTE: (Optional) Junction box can be omitted for special installations or where permitted by local electrical code.

4: Run low voltage wires from junction box to remote junction box with blank cover plate.

NOTE: Refer to installation instruction included with dimmer and power supply.

5: Carefully snap fixture body onto mounting clip(s). Slide receiving bracket to lock in place. Ensure low-voltage wires are not damaged during installation.

