

## Installation Instructions for Monorail 2"-96" Rigid Standoffs

### IMPORTANT INFORMATION

- This product is ETL listed for indoor dry locations.
- The product is intended to be used with Edge Lighting Monorail systems only.
- Use Monorail standoffs where the Monorail sections join together and approximately every 3 feet max throughout the Monorail run.

**SAVE THESE INSTRUCTIONS!**



### Install the Standoff

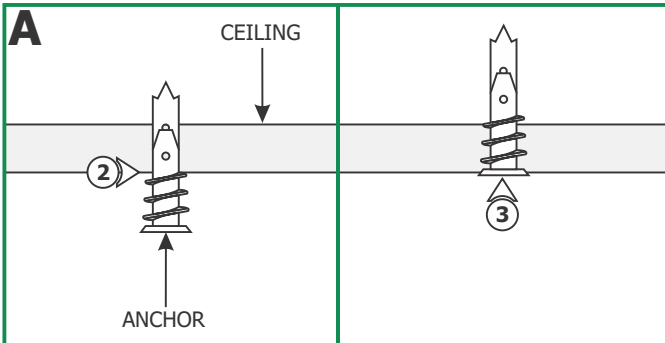

- 1: Hold the Monorail section against the ceiling or use a plumb bob to mark the standoff locations onto the ceiling (this may require more than one person).
- 2: Tap the anchors onto the marked locations up to the threaded portion with a hammer.
- 3: Screw the threaded portion of the anchors in with a Phillips screwdriver.

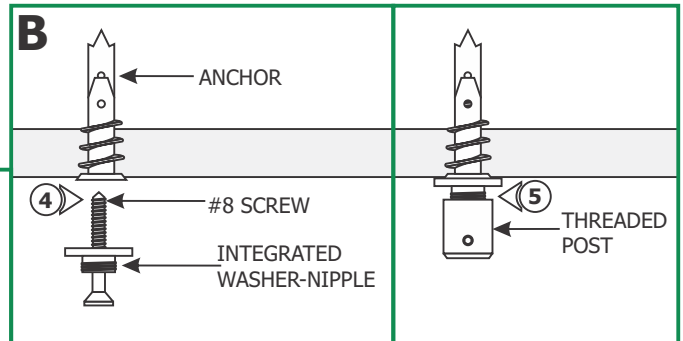

- 4: Mount the integrated washer-nipple to the anchor with the #8 screw provided.
- 5: Tighten the threaded post completely onto the integrated washer-nipple.

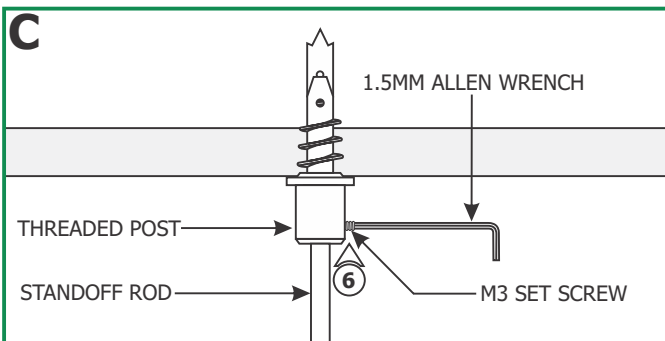

**NOTE:** To resize the standoff height, refer to "Shortening the Standoff Height" section on page 2 before proceeding with these steps.

- 6: Push the standoff rod completely into the threaded post and tighten the M3 set screw with the 1.5mm Allen wrench.
- 7: Repeat steps 4 through 6 for the remaining standoffs.

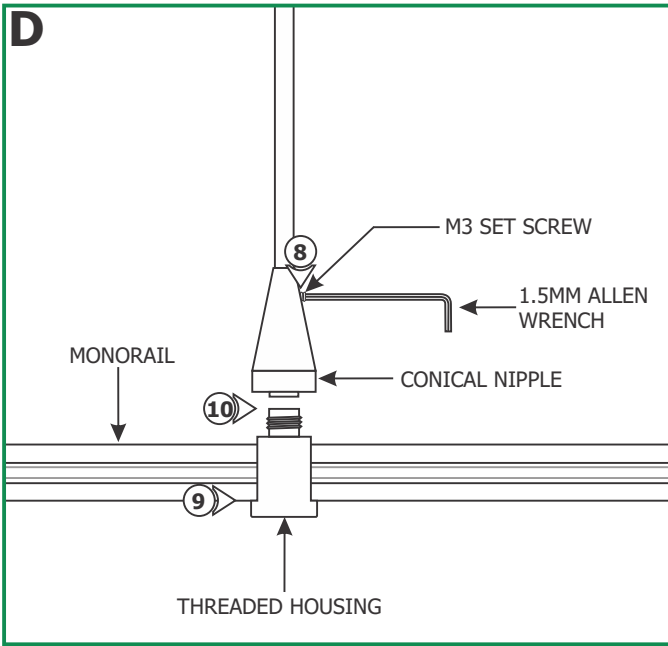

- 8:** Slightly loosen the M3 set screw on the conical nipple of each of the standoffs with the 1.5mm Allen wrench so that the conical nipples can rotate easily.
- 9:** Place the Monorail into the threaded housings (this may require more than one person).
- 10:** Tighten the threaded housings to the conical nipples (this may require more than one person). **Make sure threaded housings are not cross threaded.**

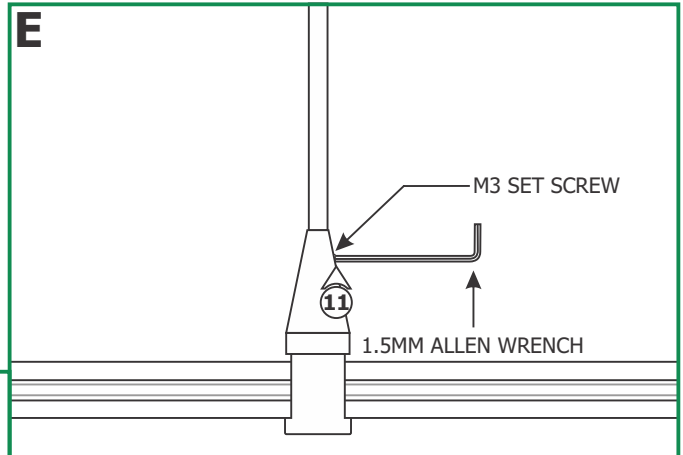

- 11:** Tighten the M3 set screw on the conical nipples with the 1.5mm Allen wrench.

## Shortening the Standoff Height (Optional)

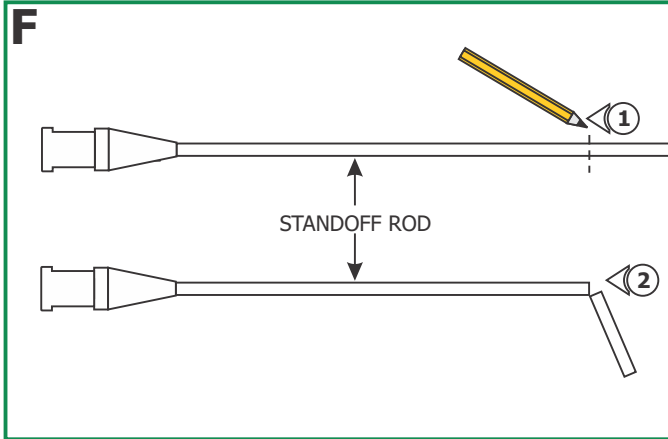

- 1:** From the end of the standoff rod, marked the rod to the amount that need to be shorten. For example to resize a 24" standoff to 17", mark 7" from end of the standoff rod.
- 2:** Using a hacksaw cut the marked section.
- 3:** Clean the burrs of the cut section.
- 4:** Repeat steps 1 through 3 for all standoffs. Make sure that all standoff heights match after resizing them.
- 5:** Follow steps 6 through 11 on "Install the Standoffs" to complete the installation.