

Installation Instructions for **Fast Jack Bubble Pendant**

IMPORTANT SAFETY INSTRUCTIONS

To reduce the risk of fire, electrical shock, exposure to excessive UV radiation, or injury to persons:

- Use this fixture indoors only.
- Do not look directly at the lamp while the fixture is on.
- **RISK OF FIRE:** Use only the type of lamp and maximum wattage indicated in this instruction manual.
- Never cover the halogen lamp with anything other than a lamp shield provided by Edge Lighting and never place flammable material close to the fixture.
- Never turn the fixture on and off by connecting and disconnecting the halogen lamp.
- Do not touch the fixture head, shade or lamp shield while the fixture is on. These surfaces may be **VERY HOT**.
- Do not touch lamp at anytime. Use a soft cloth instead as oil from skin may damage lamp.
- It is normal for a new halogen lamp to produce minor smoke when first turned on.
- Do not operate the luminaire with a missing or damaged shield.
- Turn power off and allow to cool before replacing lamp.



IMPORTANT INFORMATION

- This instruction shows a typical installation.

SAVE THESE INSTRUCTIONS!

Adjust the Fixture Height

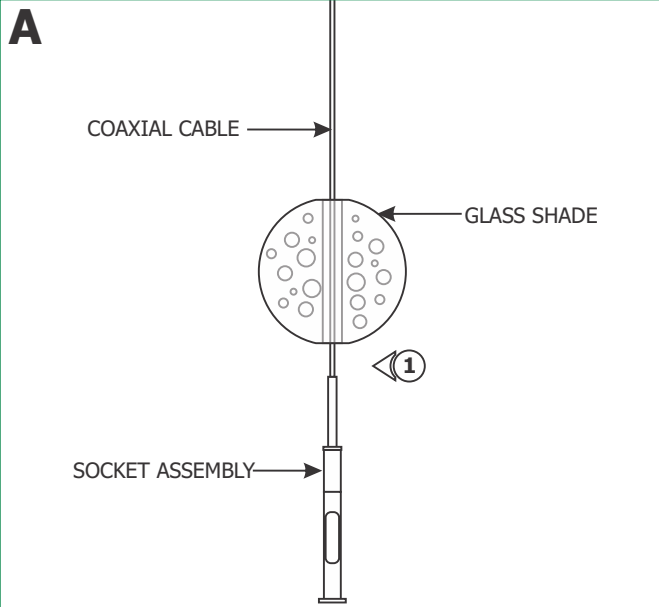

- 1:** Feed the coaxial cable through the glass shade, and rest the glass shade over the socket assembly.

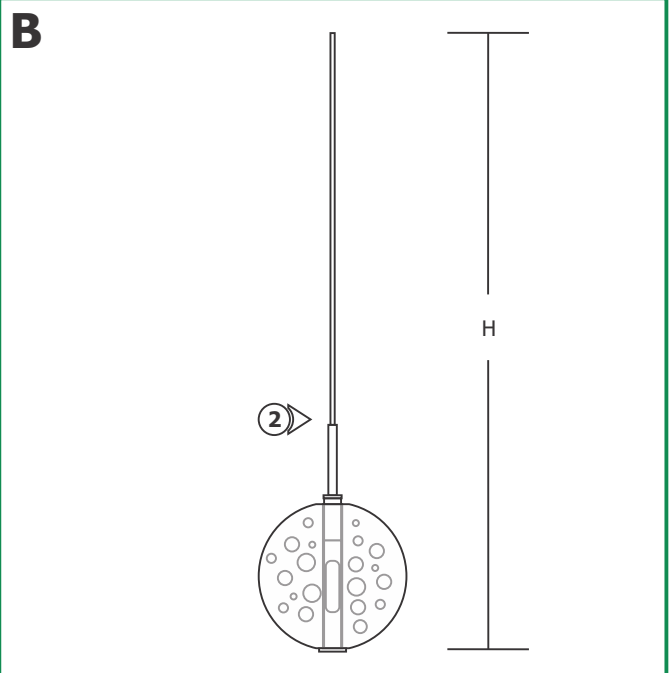

- 2:** Cut the coaxial cable to the desired height (H) with a sharp cutter. The overall fixture height is measured from the bottom of the glass shade to the end of the coaxial cable.

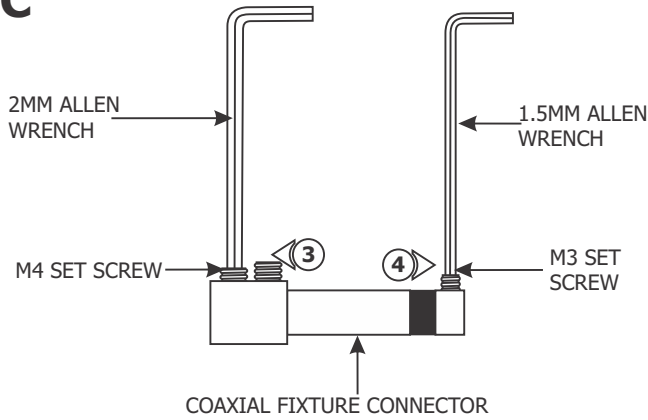
C

3: Loosen the two M4 set screw on base of the coaxial fixture connector with the 2mm Allen wrench provided. **Do not remove these set screws.**

4: Remove the M3 set screw on tip of the connector with the 1.5mm Allen wrench provided.

5: Feed the coaxial cable through the conical nipple and flared side of the strain relief tube. Slide the conical nipple and strain relief tube down the coaxial cable.

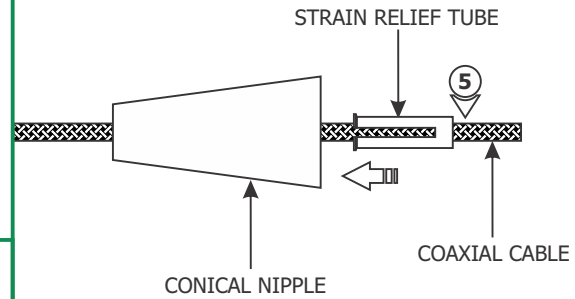
D

6: Feed the coaxial cable into the coaxial fixture connector. The coaxial cable will come to a stop point.

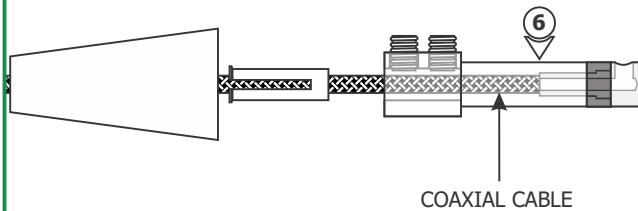
E

7: Keep feeding the coaxial cable in until the inner wire is visible in the screw hole of the fixture connector tip. The outer metal jacket will start to wrinkle.

8: Hold the fixture connector in place. Replace and tighten the M3 set screw on fixture connector tip with the 1.5mm Allen wrench.

9: Pull down the outer metal jacket to smooth the wrinkles.

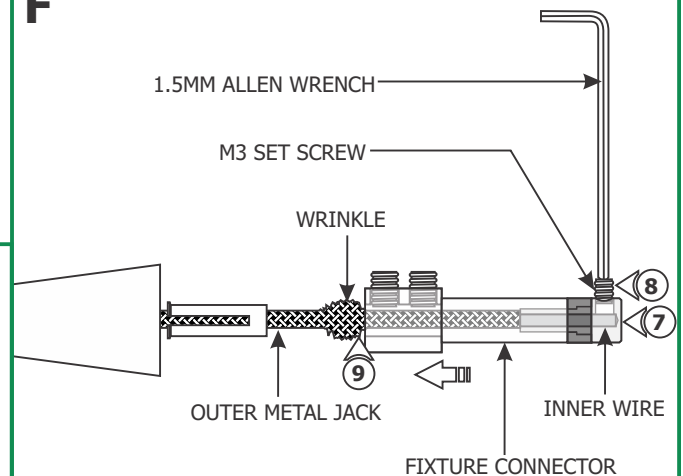
F

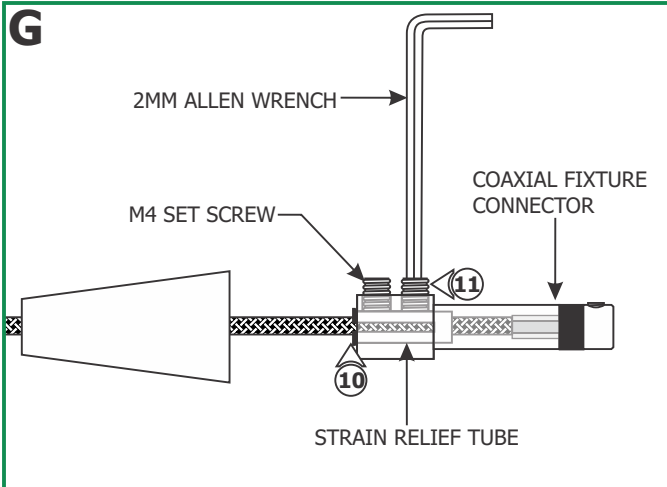

10: Push the strain relief tube completely into the coaxial fixture connector. Make sure the slot on the strain relief tube is not inline with the M4 set screw.

11: Tighten the two M4 set screws with the 2mm Allen wrench.

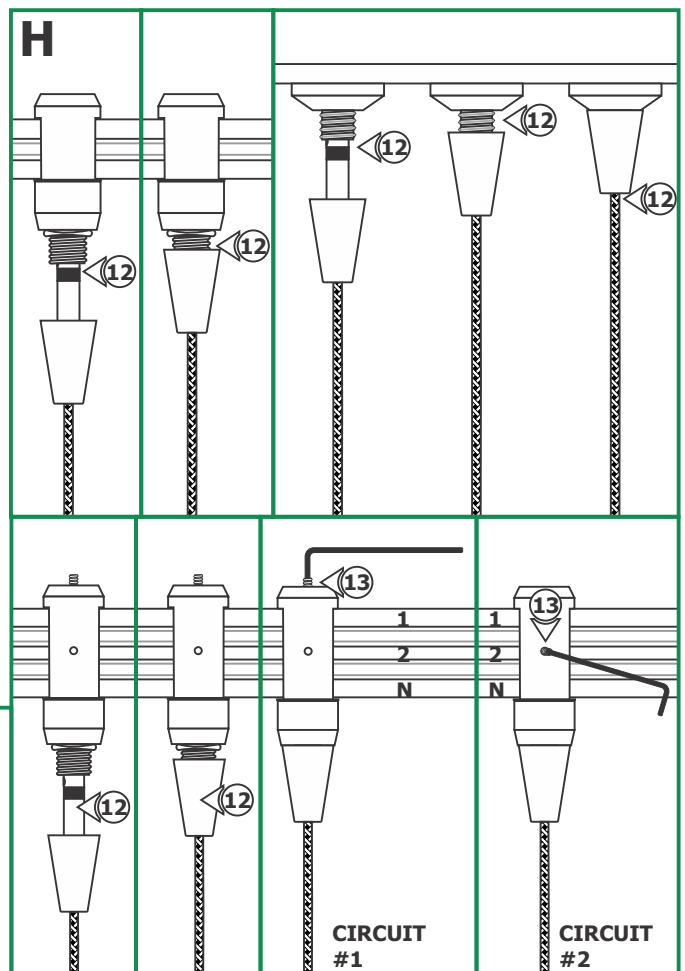

12: Use fingers to tighten the Fast Jack fixture connector into the Fast Jack system connector (Monorail, Monorail Wall, Monorail 2 Circuit, or multi-port and mono-point canopies. Refer to the instructions provided with the system connector or canopy).

13: Refer to the instructions provided with the Monorail 2 Circuit fixture connector to choose the Circuit #1 or Circuit #2.

Install the Lamp

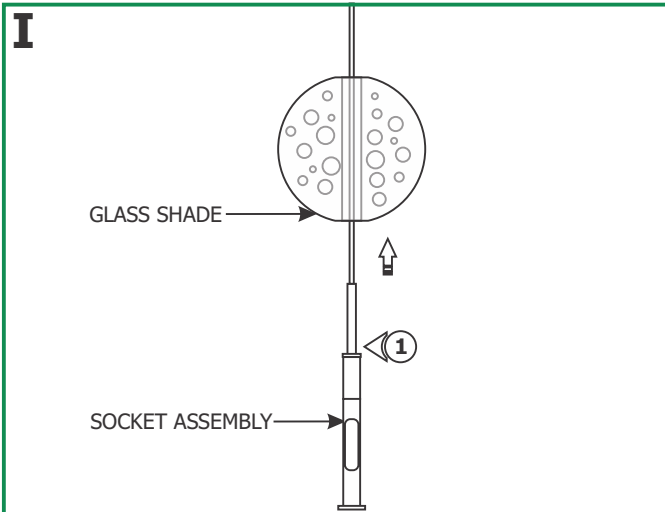

CAUTION: To reduce risk of a burn or electrical shock during lamping, disconnect the power to the fixture.

NOTE: Do not loosen or otherwise modify the power cable set screw. This will cause damage to the fixture.

1: Lift the glass shade up to expose the socket assembly.

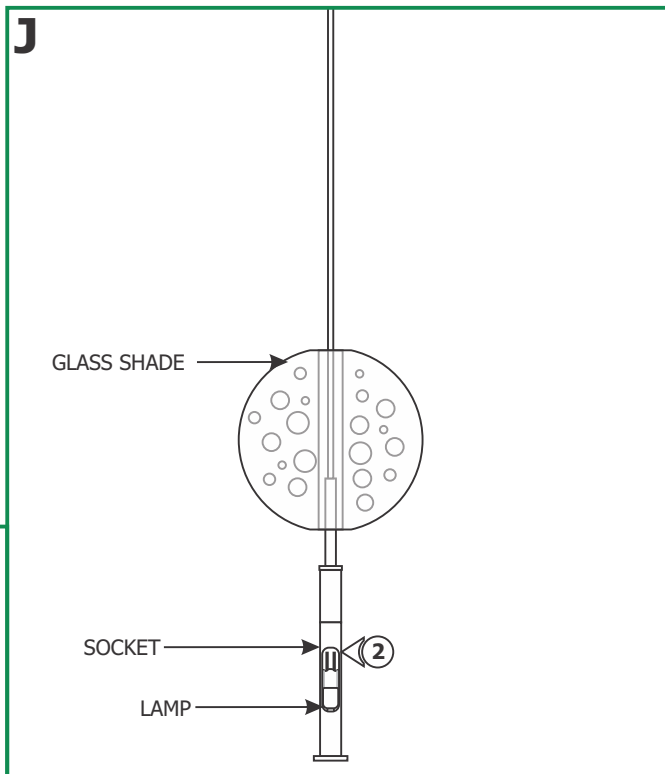

CAUTION: To reduce risk of a burn or electrical shock during lamping, disconnect the power to the fixture.

NOTE: Use only fingers and a soft cloth to install the lamps.

Use **MAX 20** Watt, Type Bi-Pin Halogen Lamp.

2: Push the lamp pins completely into the socket holes.

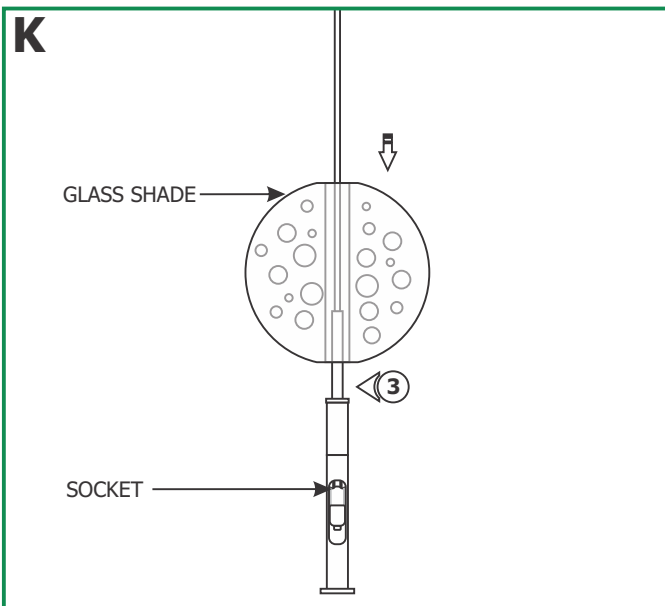

3: Carefully lower the glass shade onto the socket assembly.

NOTE: Use only a clean damp towel to clean the bubble balls. Do not use any cleaning solutions which may cause the colored bubble balls to get damaged.