

Installation Instructions for **Bright Idea 9 and 17 Light Suspension**

IMPORTANT INFORMATION

- This product is ETL listed for indoor dry locations.

SAVE THESE INSTRUCTIONS!

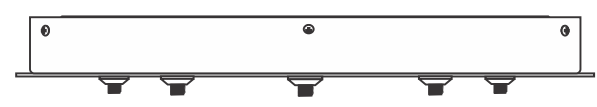

Running the Power from a Remote Transformer to the Fast Jack Canopy

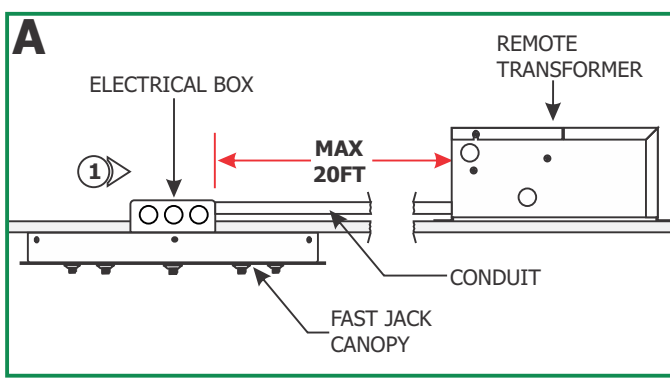

1: Run the low voltage wires from a remote transformer to electrical box where Fast Jack canopy is going to be installed. It is recommended to install the remote transformer near the electrical box to avoid voltage drop. Refer to the instructions provided with remote transformer for low voltage wire size chart. Refer to the low voltage wire size chart provided with the remote transformer.

Install the Canopy

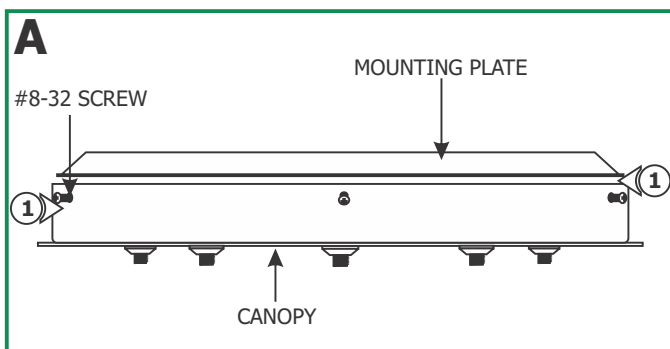

1: Loosen and remove the six #8-32 screws around the canopy to remove the mounting plate.

- 2:** Feed the low voltage coming from the remote transformer through mounting plate center hole.
- 3:** Align the mounting plate slots with the electrical box holes and secure it to the electrical box holes with the provided two #8-32 screws.

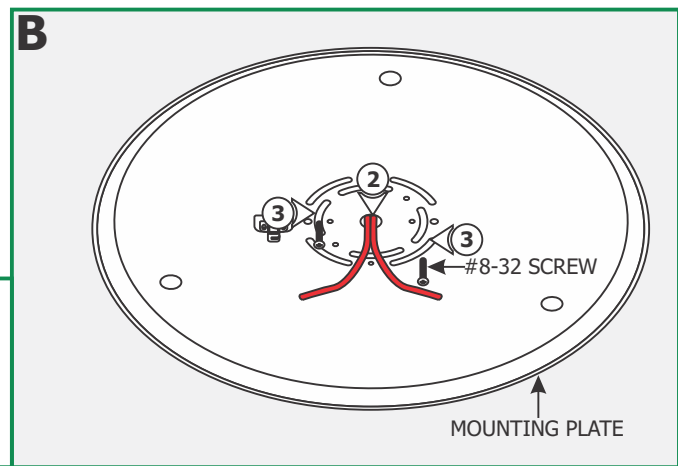

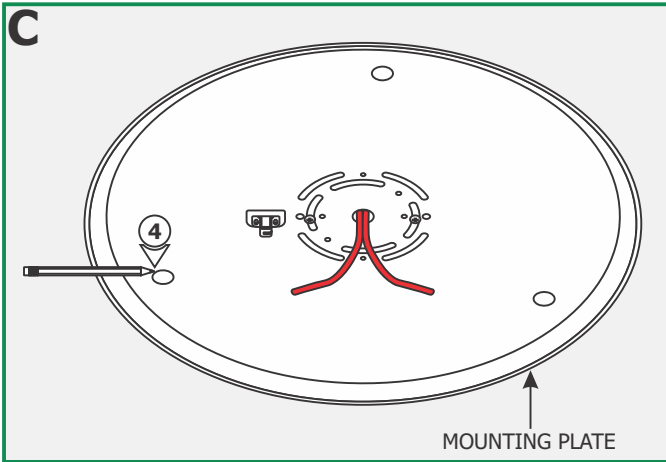

4: Mark the three mounting plate holes on the ceiling.

- 5:** Tap the anchors through the mounting plate holes onto the marked point up to the threaded portion with a hammer.
- 6:** Screw in the threaded portion of the anchors with a Phillips screwdriver.

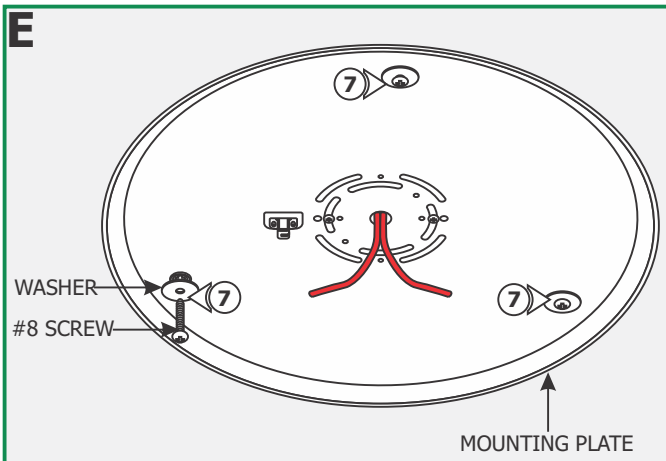
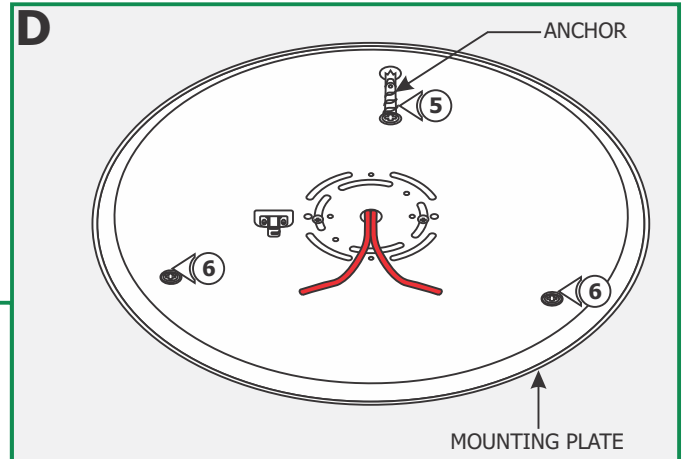

7: Secure the mounting plate to the anchors with the provided #8 screws and washers.

- 8:** Insert one end of the safety cable into the safety bracket of mounting plate and the other end into the canopy safety bracket.

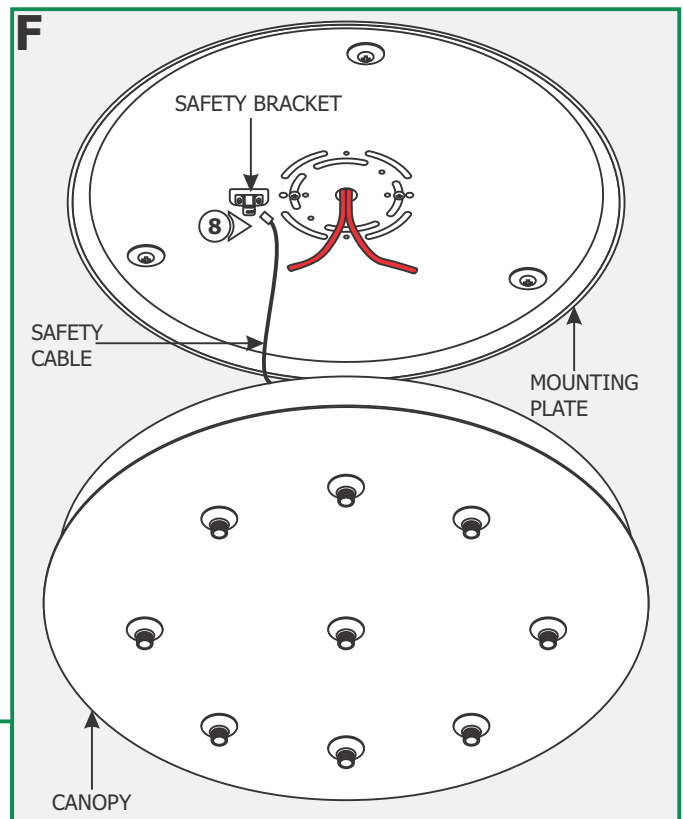

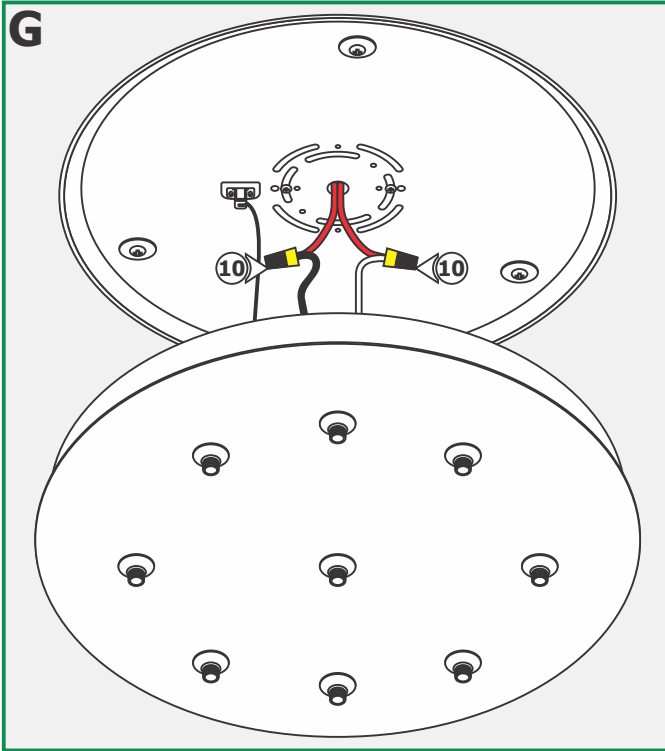

9: Make sure that the mounting plate is grounded in accordance with local electrical codes.

10: Connect each canopy wire to one low voltage transformer wire with a wire nut.

11: Place all wires and wire nut connections inside the canopy.

12: Place the canopy onto the mounting plate and tighten the six #8-32 screws.

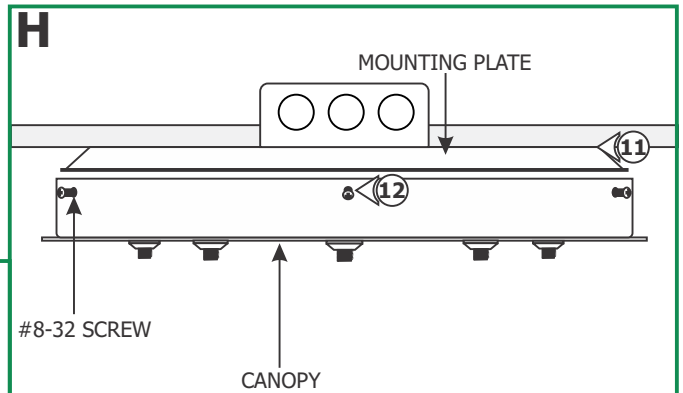

Installing Zzz on Canopy

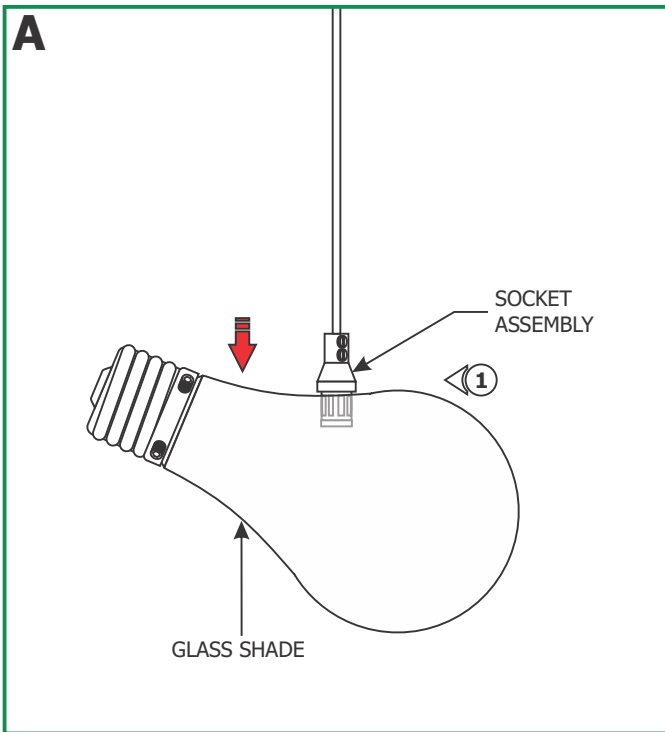

CAUTION: To reduce risk of a burn or electrical shock during lamping, disconnect the power to the fixture.

1: While holding the socket assembly, carefully pull the glass shade completely off.

B

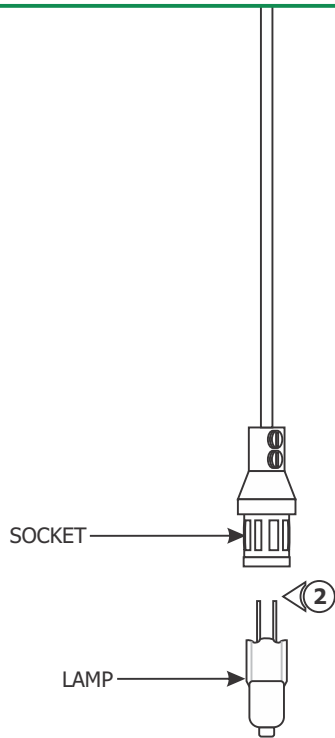

CAUTION: To reduce risk of a burn or electrical shock during lamping, disconnect the power to the fixture.

NOTE: Use only fingers and a soft cloth to install the lamps.

Use **MAX 20** Watt, Type Bi-Pin Halogen Lamp. 

2: Push the lamp pins completely into the socket holes.

3: Push the socket assembly back into the glass shade hole to secure in place.

C

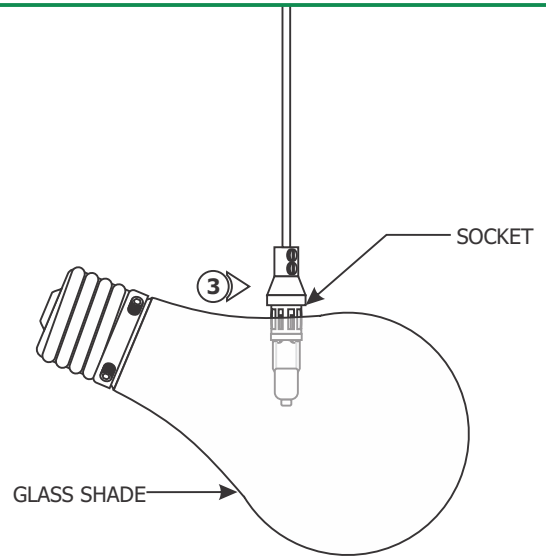

Installing Outlaw on Canopy

A

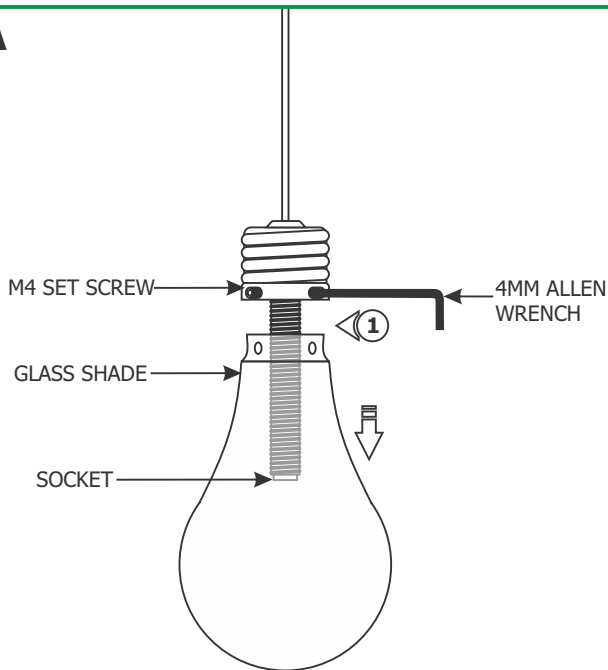

CAUTION: To reduce risk of a burn or electrical shock during lamping, disconnect the power to the fixture.

1: Slightly loosen the three M4 set screws (Do Not Remove) with the 2mm Allen wrench provided, to remove the glass shade.

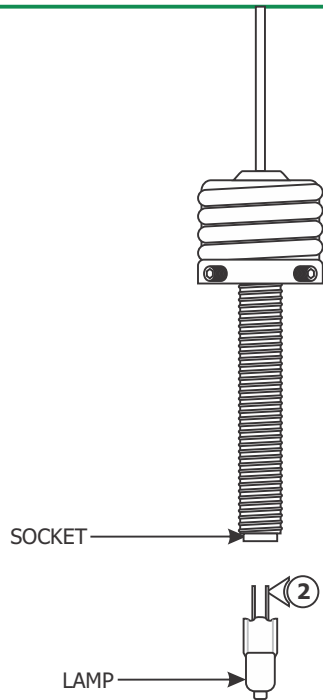
B

CAUTION: To reduce risk of a burn or electrical shock during lamping, disconnect the power to the fixture.

NOTE: Use only fingers and a soft cloth to install the lamps.

Use **MAX 20** Watt, Type Bi-Pin Halogen Lamp. 

2: Push the lamp pins completely into the socket holes.

3: Align the socket assembly set screws to the glass shade hole. While holding the glass shade in place, secure it by tightening the three M4 set screws with the provided 2mm Allen wrench.

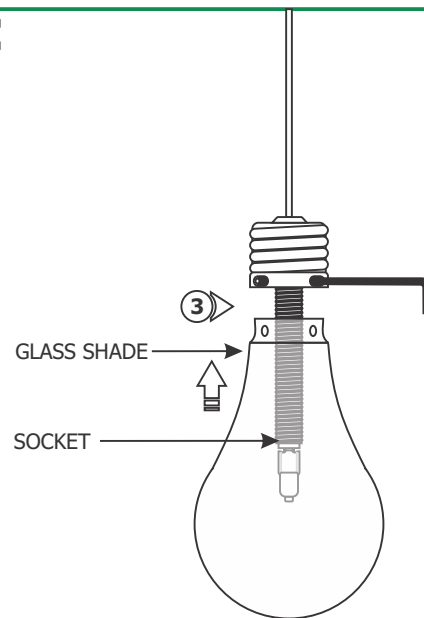
C

4: Loosen the two M4 set screw on base of the coaxial fixture connector with the 2mm Allen wrench provided. **Do not remove these set screws.**

5: Remove the M3 set screw on tip of the connector with the 1.5mm Allen wrench provided.

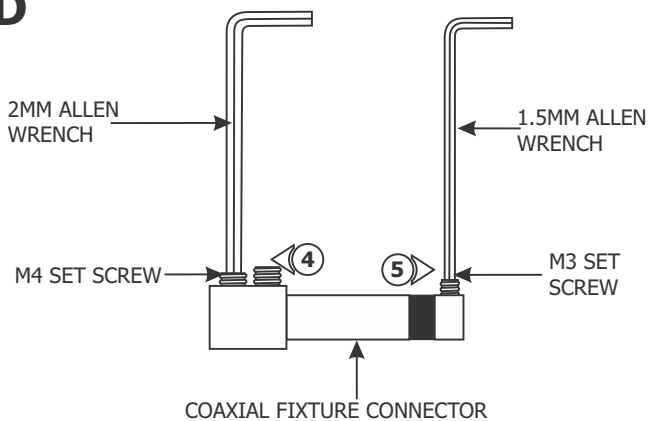
D

6: Feed the coaxial cable through the conical nipple and flared side of the strain relief tube. Slide the conical nipple and strain relief tube down the coaxial cable.

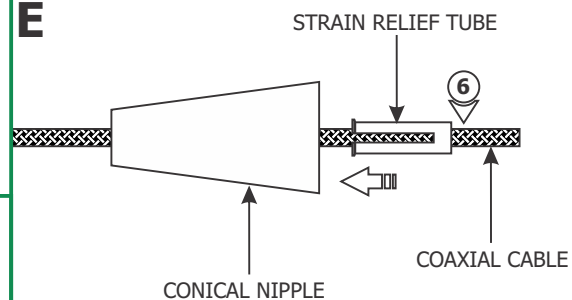
E

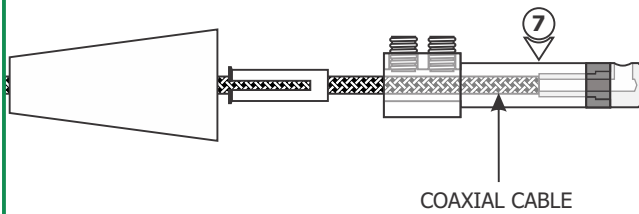
F

7: Feed the coaxial cable into the coaxial fixture connector. The coaxial cable will come to a stop point.

8: Keep feeding the coaxial cable in until the inner wire is visible in the screw hole of the fixture connector tip. The outer metal jacket will start to wrinkle.

9: Hold the fixture connector in place. Replace and tighten the M3 set screw on fixture connector tip with the 1.5mm Allen wrench.

10: Pull down the outer metal jacket to smooth the wrinkles.

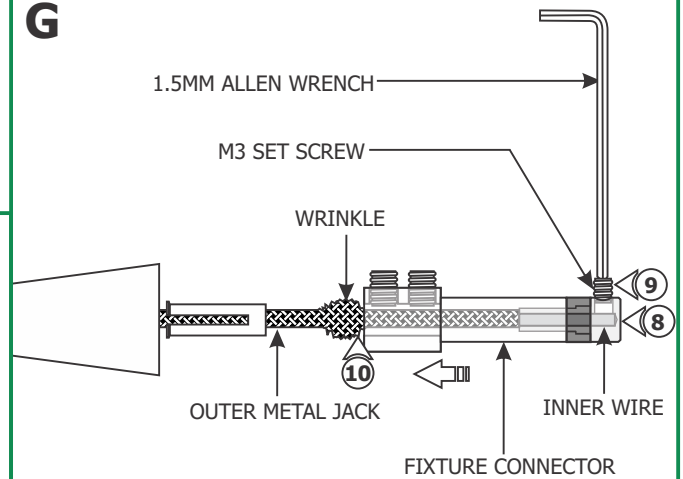
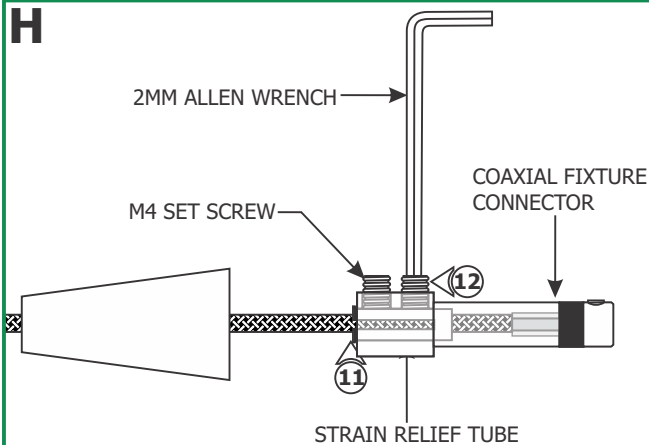
G**H**

11: Push the strain relief tube completely into the coaxial fixture connector. Make sure the slot on the strain relief tube is not inline with the M4 set screw.

12: Tighten the two M4 set screws with the 2mm Allen wrench.

CAUTION: Risk of Fire: The total load of the Fast Jack canopy ports should not exceed the remote transformer rated capacity.

13: Use fingers to tighten each Fast Jack fixture connector into one Fast Jack canopy port.

J