

Installation Instructions for Cirrus Channel, Wall Wash Lens

IMPORTANT INFORMATION

- This instruction shows a typical installation.
- Per NEC Article 410.16(A)(1)(3) & 410.16(C)(5). Approved for Closet Storage Areas.

SAVE THESE INSTRUCTIONS!

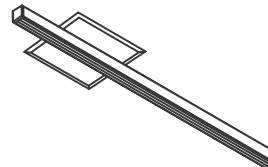

Connecting the Channel

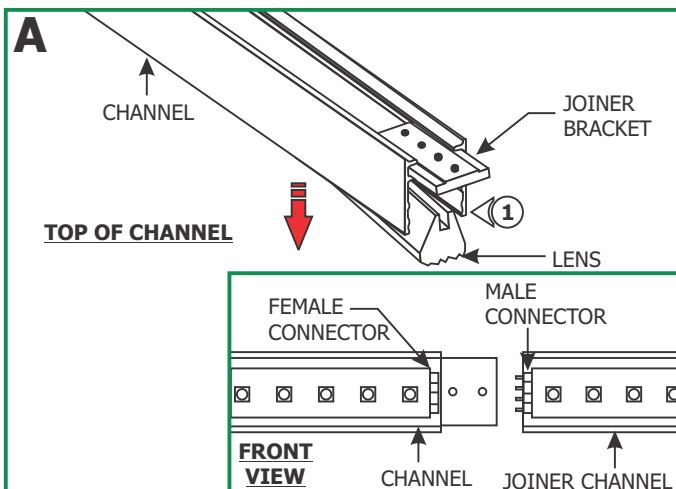

NOTE: Omit this section if the channel is made out of a single piece (120" or less).

NOTE: Prior to installation, Cirrus Channel must be connected to one another to make proper measurements on surface for markings.

NOTE: It is recommended more than one person to assist in this installation.

NOTE: When using Edge Lighting Slim Profile Junction Box (C-1RE-BOX), continue to "Install the Channel using the Junction Box (C-1RE-JBOX)" on page 4.

1: Lift a section of the lens at the end of the channels where the connectors are visible. Slide the channel over the joiner bracket make sure that the male & female connectors mate properly.

2: Push the lens back into the channel.

Install Channel on a Standard Junction box w/plaster ring

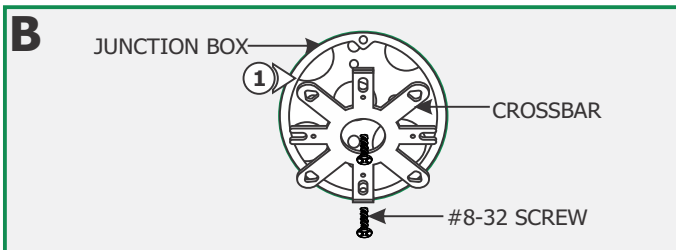

1: Mount the crossbar to the Junction box holes with the two #8-32 screws provided.

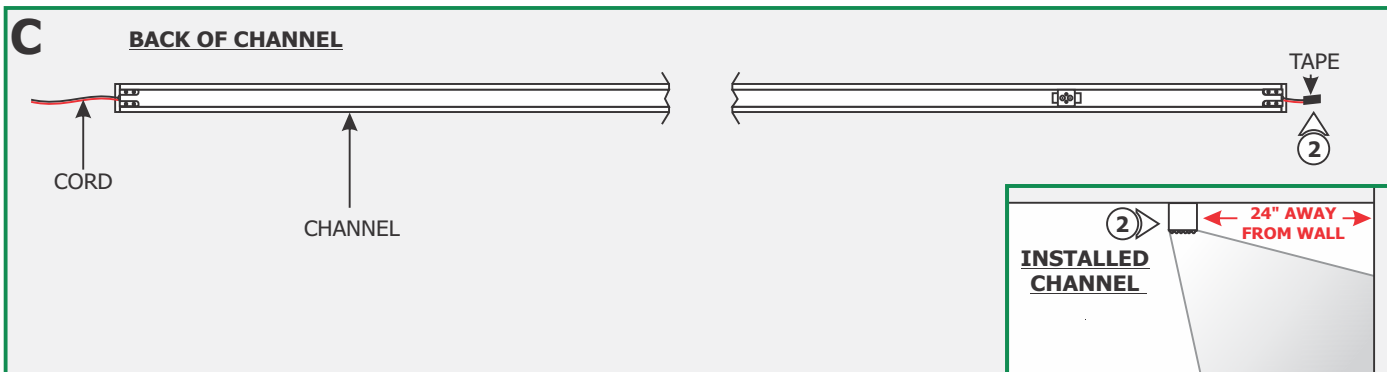

NOTE: Remote power supply must be installed within 40ft of Junction box. The low voltage 24V DC wires must be present in Junction box before installing the channel. Refer to the installation instructions provided with the power supply. See page 7 for wiring diagram.

2: Wall wash channel mounts in one direction, **24" away from the wall to properly light the desired area.** Choose the cord on one end that is closest to the junction box. Cut the unused cord leaving 2" exposed. Wrap the end of the unused cord with electrical tape.

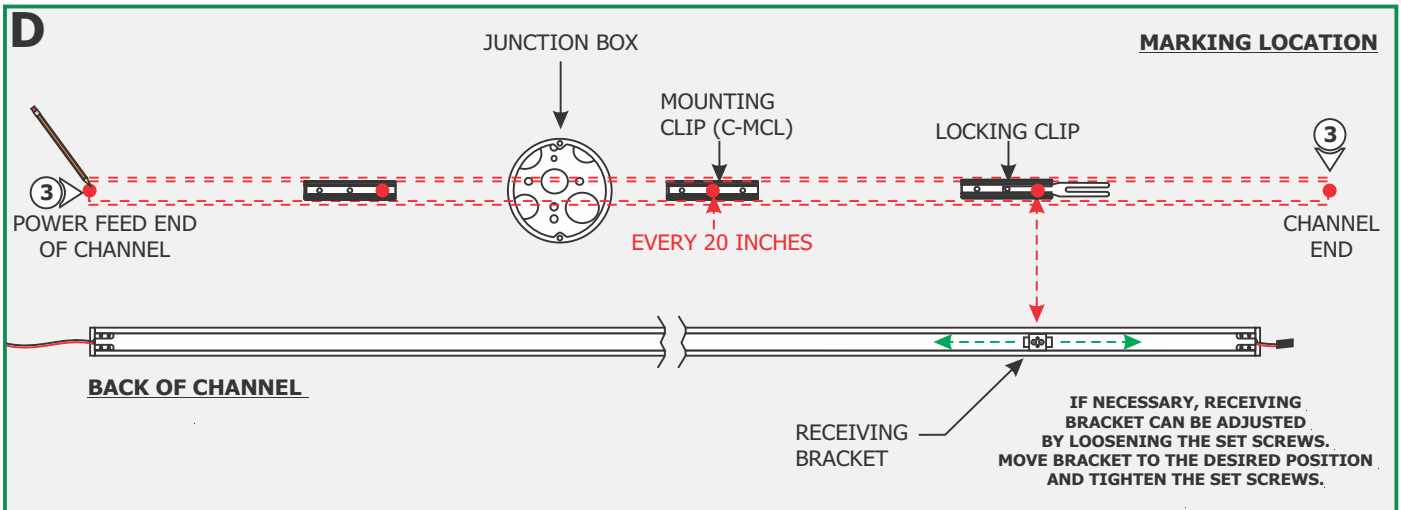

3: Lay the channel to the desired location & make all necessary markings which will consist of the channel ends, locking clips and mounting clips. Mounting clips must be installed every 20" from each locking clip, **locking mounting clips are not necessary for channels under 2ft.**

NOTE: If the receiving bracket interferes with the junction box, then relocate the bracket by loosening the screws and make the necessary adjustments.

NOTE: The channel must pass through the center of the junction box.

4: After all markings and required measurements are done, take apart channels from each other.

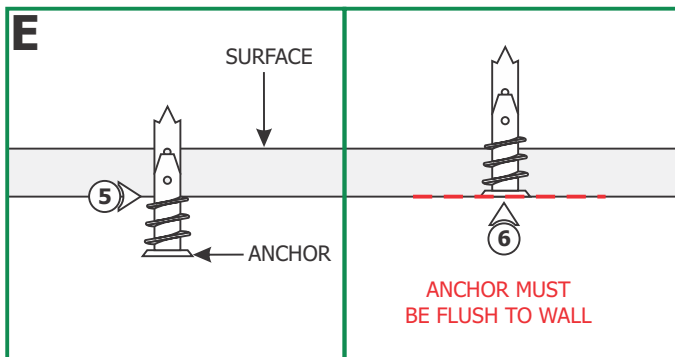

NOTE: Steps 5 and 6 are for drywall mounting. Omit these steps if mounting the clips to a wood surface directly.

5: Tap the anchors onto the marked points up to the threaded portion with a hammer.

6: Screw in the threaded portion of the anchors with a Phillips screwdriver.

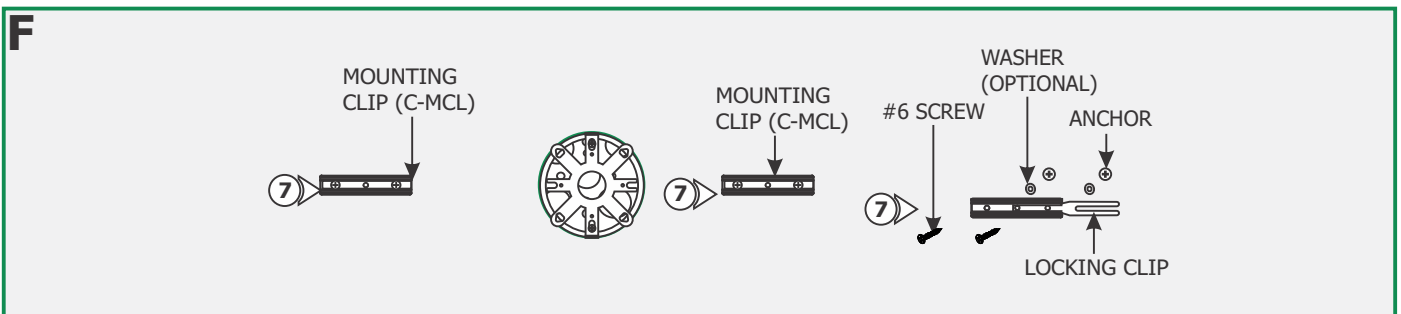

7: Line up the locking clips & mounting clips to anchor holes and secure them by tightening the two #6 screws through the clip holes followed by the washers into the anchors.

NOTE: Tighten the screws on the clips until the clips bend inside. This ensures the clips fit properly into the channel.

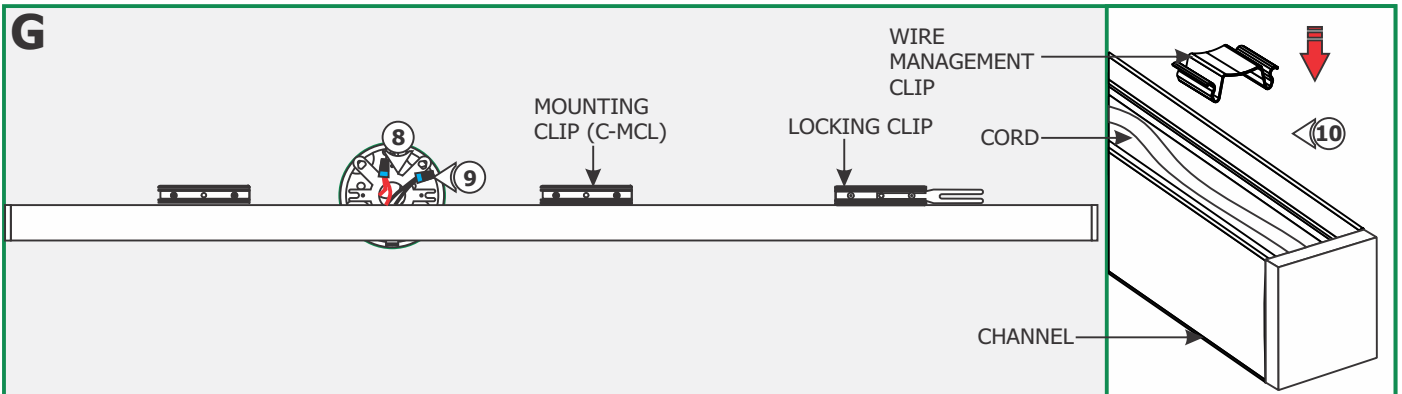

- 8:** Connect the red power supply (24VDC+) wire to red strip wire with a wire nut inside the Junction box.
- 9:** Connect the black power supply (24VDC+) wire to black strip wire with a wire nut inside the Junction box.
- 10:** Snap the wire management clip to hold the cable in place if necessary.

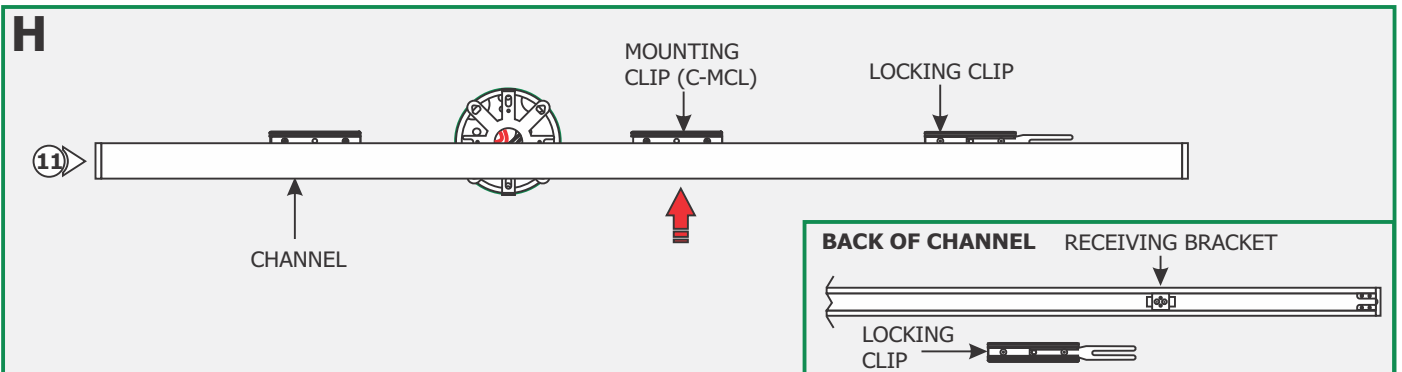

- 11:** Carefully **SNAP** channel onto the locking/mounting clips then slide 2" into receiving bracket to lock in place. Make sure not to nick the wires.
- 12:** If applicable, connect the remaining channels by following "Connecting the Channel" on page 1.

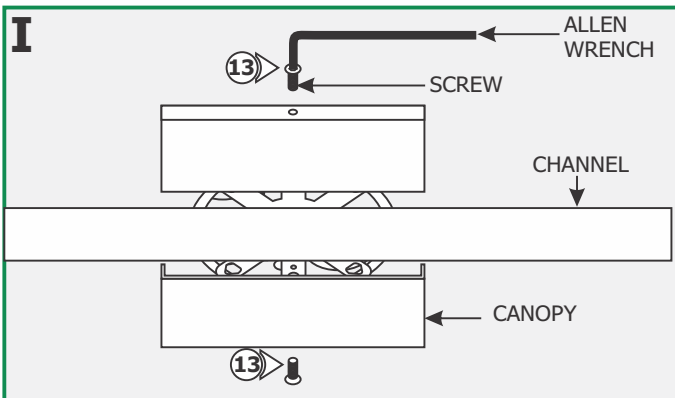

- 13:** Place each canopy piece against the channel & line up the canopy hole with the crossbar hole. Secure the canopy in place with the screw & Allen wrench provided.

Install the Channel using the Junction Box (C-1RE-JBOX)

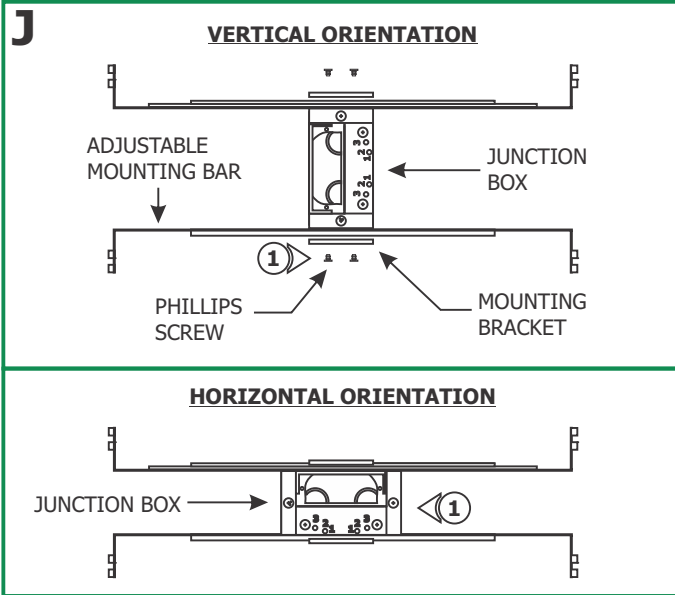

1: Mount each adjustable mounting bar to one side of the junction box (mounts to any side of the housing depending on the orientation of the channel) and secure them with the mounting brackets and two Phillips screws provided.

NOTE: The adjustable mounting bars mount to studs that are spaced 16" to 24" apart.

2: Select the location between the two studs for the Junction box to be mounted.

3: Place the adjustable mounting bars between the studs.

4: Make sure the lips on the adjustable mounting bars are against the studs. Secure the adjustable bars to the studs with the eight #8 screws.

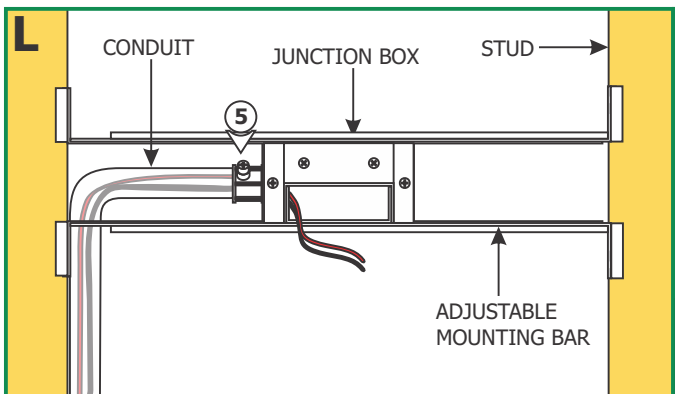
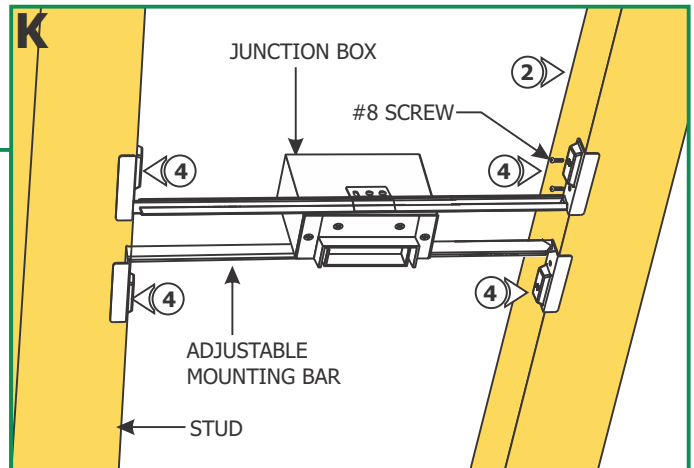

5: Remove a knockout to install the power line conduit.

6: Install the conduit and run the low voltage 24V DC power wires coming from the remote power supply to the Junction box.

NOTE: Remote power supply must be installed within 40ft of Junction box. The low voltage 24V DC wires must be present in Junction box. See wiring diagram on page 7 for more information.

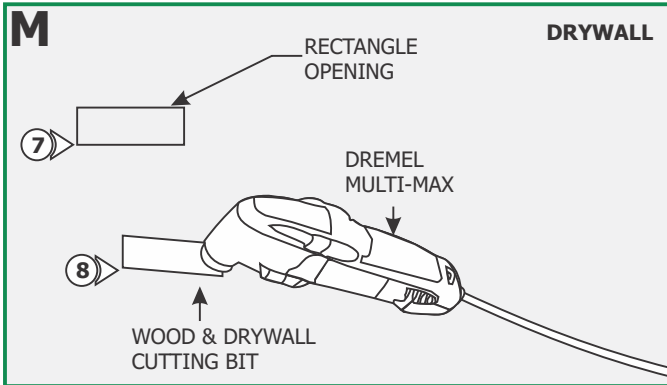

7: Mark a rectangle shape on drywall where the junction box opening will be located depending on selected position.

8: Cut out the marked rectangle opening, using a "Dremel Multi-Max" with the "wood & drywall" cutting bit.

9: Install & finish drywall.

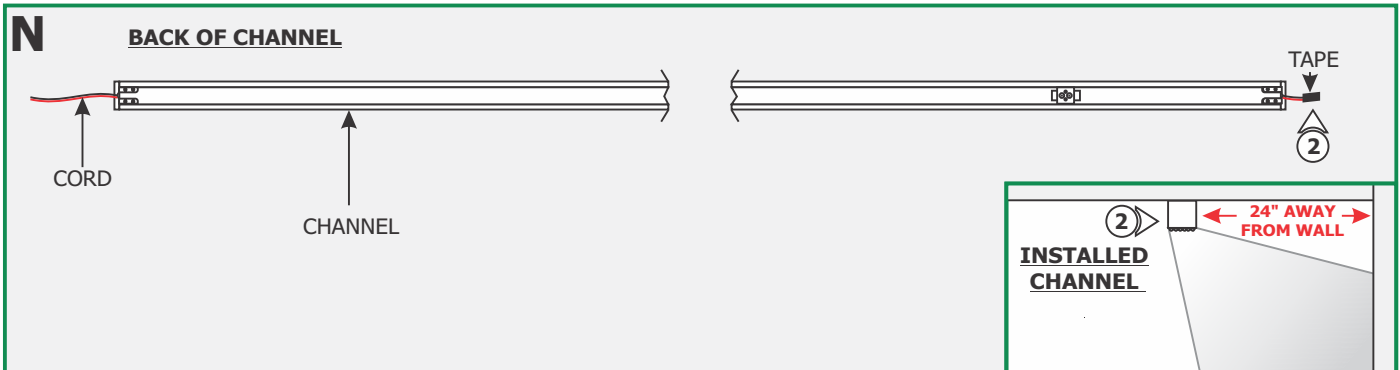

NOTE: Remote power supply must be installed within 40ft of Junction box. The low voltage 24V DC wires must be present in Junction box before installing the channel. Refer to the installation instructions provided with the power supply. See page 6 for wiring diagram.

10: Wall wash channel mounts in one direction, **24" away from the wall to properly light the desired area**. Choose the cord on one end that is closest to the junction box. Cut the unused cord leaving 2" exposed. Wrap the end of the unused cord with electrical tape.

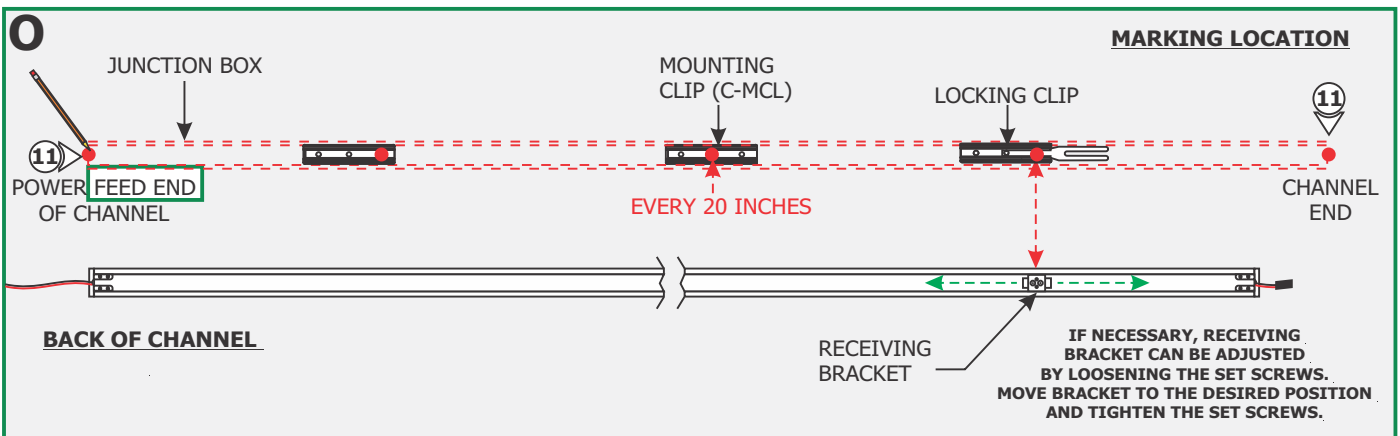

11: Lay the channel to the desired location & make all necessary markings which will consist of the channel ends, locking clips and mounting clips. Mounting clips must be installed every 20" from each locking clip, **locking mounting clips are not necessary for channels under 2ft.**

NOTE: If the receiving bracket interferes with the junction box, then relocate the bracket by loosening the screws and make the necessary adjustments.

NOTE: The channel must pass through the center of the junction box.

12: After all markings and required measurements are done, take apart channels from each other.

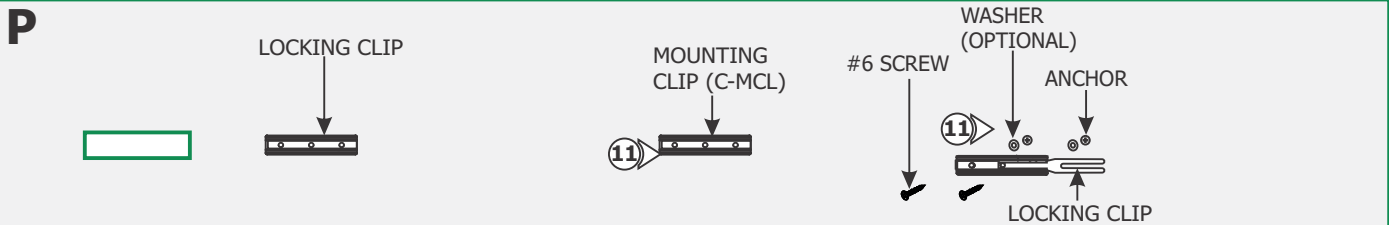

11: Line up the locking clips & mounting clips to anchor holes and secure them by tightening the two #6 screws through the clip holes followed by the washers into the anchors.

NOTE: Tighten the screws on the clips until the clips bend inside. This ensures the clips fit properly into the channel.

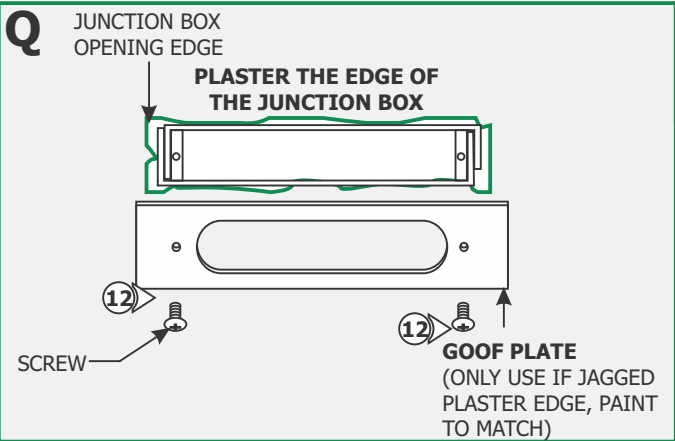

12: Optional: Use the Goof Plate if the junction box opening has a lot of imperfection/jagged edges. Install the provided goof plate (paint to match prior) with the two screws.

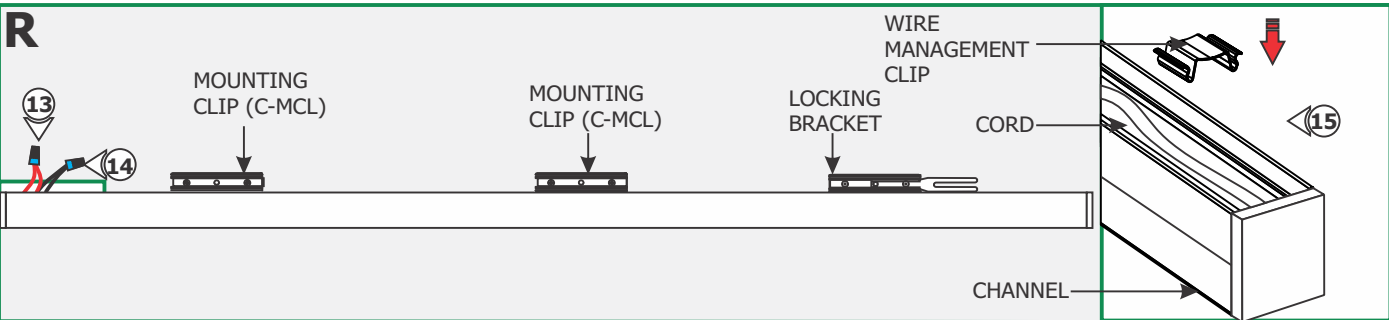

13: Connect the red power supply (24VDC+) wire to red strip wire with a wire nut inside the Junction box.

14: Connect the black power supply (24VDC+) wire to black strip wire with a wire nut inside the Junction box.

15: Snap the wire management clip to hold the cable in place if necessary.

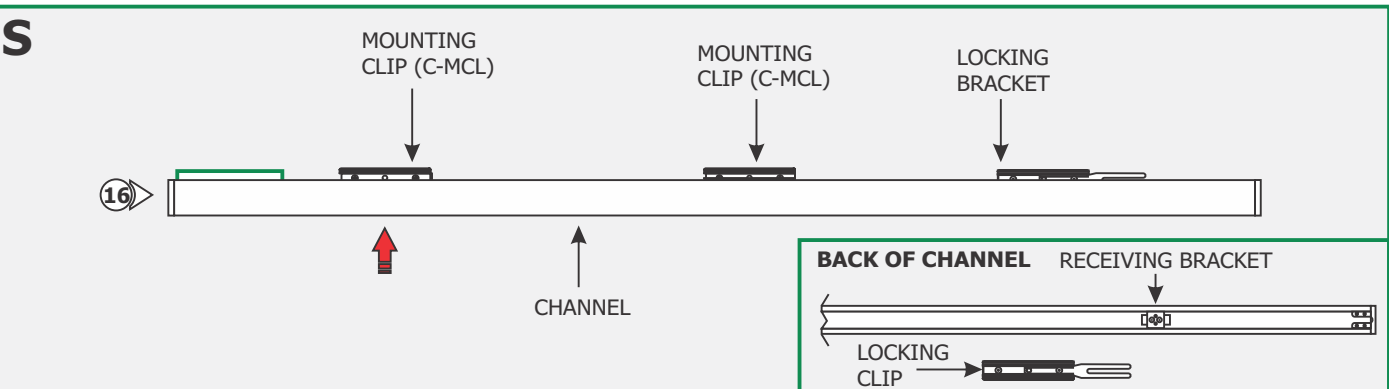

16: Carefully **SNAP** channel onto the locking/mounting clips then slide 2" into receiving bracket to lock in place. Make sure not to nick the wires.

17: If applicable, connect the remaining channels by following "Connecting the Channel" on page 1.

96W, 24VDC LOW VOLTAGE WIRE SIZE CHART

3% VOLTAGE DROP	WIRE LENGTH IN FT	UP TO 33FT	34FT-52FT	53FT-86FT	87FT-130FT
	WIRE SIZE	14 AWG	12 AWG	10 AWG	8 AWG
	VOLTAGE AT END OF THE WIRE	23.28 VDC	23.29 VDC	23.28 VDC	23.28 VDC

GENERAL WIRING DIAGRAM

