

Cast Bronze Underwater (UW2250) Specification Sheet

Project Name:	Location:	MFG: Philips Hadco
Fixture Type:	Catalog No.:	Qty:

Ordering Guide

Example: UW2250 N

Product Code	UW2250	Cast Bronze Underwater
Finish	N	Natural Brass

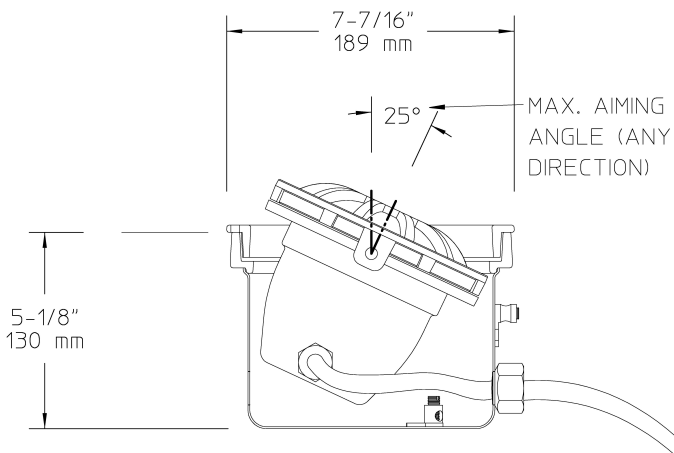

Specifications

HOUSING:

Spun stainless steel with cast nickel bronze trim. Stainless steel with integral bonding lugs and hub for connecting 1/2" or 3/4" conduit. Fasteners are 300 series stainless steel. Gasketing is silicone. Spun stainless steel. Rockguard is marine grade bronze. Integral and furnished as standard on all fixtures. This enables fixture to be used in accordance with NEC Article 680-51 in installations without an external low-water cutoff.

FINISH:

Natural Brass (N) is as-cast and tumble polished.

OPTICAL ASSEMBLY:

Clear convex lens, high temperature glass furnished with silicone O-ring for watertight seal.

LAMPING:

250W maximum. 250W T4 lamp is included with fixture.

ELECTRICAL ASSEMBLY:

Standard 10 ft. 16-3 AWG, 105° C, STOW water-resistant cord. Fixture is pre-wired and potted to prevent water entry. Mini-candelabra socket (E11).

WARRANTY:

Lifetime limited warranty.

CERTIFICATIONS:

ETL listed to U.S. safety standards for wet locations. cETL listed to Canadian safety standards for wet locations. Manufactured to ISO 9001:2008 Standards.

CORROSIVE CONDITIONS:

Proper pH balance is required when using copper and brass lighting fixtures in corrosive applications. If the water was allowed to remain in acid conditions, with chlorine or bromine present, copper corrosion occurs. Our laboratory testing concludes that chlorine/bromine does work better at a pH below 7.2. However, there are consequences that will result. Corrosion can present a problem below 7.0. As the pH falls below 7.2, chlorine/bromine can become increasingly more aggressive and irritating. Brass and copper fixtures will experience some natural patina. The fixture will turn a darker brown color as the patina process occurs.

Height :

5 1/8" (130mm)

Width:

7 7/16" (189mm)

Max. Weight:

4.2 lbs.