

# Beacon (1010) Specification Sheet

Project Name:	Location:	MFG: Philips Hadco
Fixture Type:	Catalog No.:	Qty:

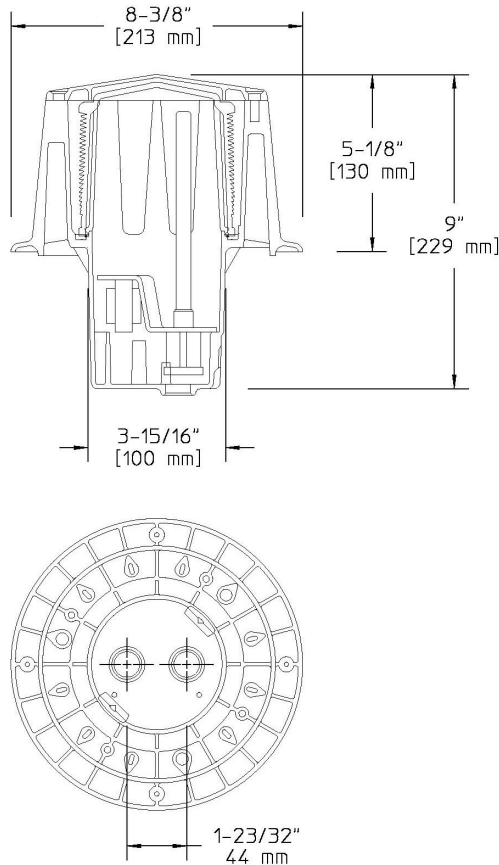

## Ordering Guide

Example: 1010 H

Product Code	1010	Beacon
Finish	H	Bronze

## Specifications

### HOUSING:

Die-cast aluminum. Removable roof for easy relamping. Fasteners are 300 series stainless steel. Molded silicone gasket seals glass, top and bottom, and prevents moisture intrusion into the fixture. NOTE: The base has two (2) 1/2" NPT conduit entrances for connection to the power source.

### FINISH:

Thermoset polyester powdercoat is electrostatically applied after a five-stage conversion cleaning process and bonded by heat fusion thermosetting. Laboratory tested for superior weatherability and fade resistance in accordance with ASTM B117 specifications.

### OPTICAL ASSEMBLY:

Clear borosilicate glass refractor lens. Fully gasketed top and bottom.

### LAMPING:

100W maximum A19 lamp.

### ELECTRICAL ASSEMBLY:

Incandescent is medium base porcelain socket with nickel-plated screw shell and center contact.

### BALLAST:

All HID ballasts are core and coil and regulated with power factors better than 90% (HPF). Ballast provides +/- 5% lamp power regulation with +/- 10% input voltage regulation. Ballasts are factory pre-wired and tested. Metal halide ballasts are capable of starting at -20° F or -30° C and HPS at -40°F or -40°C. NOTE: All ballasts are EISA / Title 20 / Title 24 compliant where applicable.

### INSTALLATION & MOUNTING:

VOLTAGE CAUTION: Some local interpretation of the NEC Section 210-6 only permit the use of 120 volt fixtures when they are mounted below 8'. Check with local authorities before specifying alternate voltages. Beacons are partially recessed. Potting compound must be used to seal the conduit wire entry. Lower housing may be recessed directly in

# Beacon (1010) Specification Sheet

Project Name:	Location:	MFG: Philips Hadco
Fixture Type:	Catalog No.:	Qty:

the ground or in concrete.

**WARRANTY:**

Three-year limited warranty.

**CERTIFICATIONS:**

ETL listed to U.S. safety standards for wet locations. cETL listed to Canadian safety standards for wet locations. Manufactured to ISO 9001:2008 Standards.

**Height :**

9 1/32" (229mm)

**Width:**

8 3/8" (213mm)

**Max. Weight:**

6.3 lb.