

Wall Washer (AUL1) Specification Sheet

Project Name:	Location:	MFG: Philips Hadco
Fixture Type:	Catalog No.:	Qty:

Ordering Guide

Example: AUL1 A S7

Product Code	AUL1	Wall Washer
Finish	A G	Black Verde
Mounting	S7	Mounting Stake

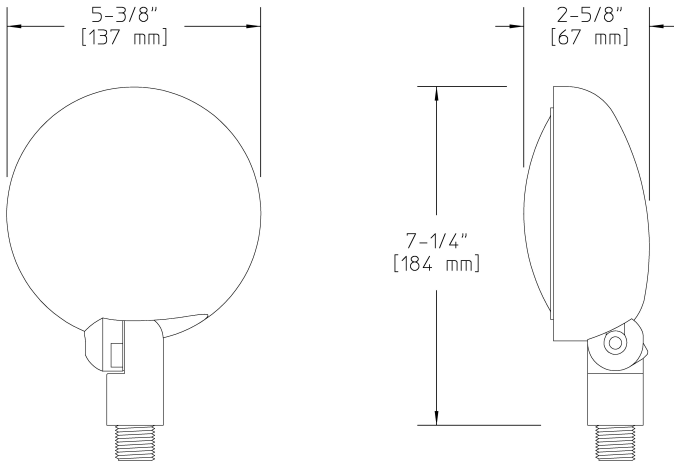

Specifications

HOUSING:

One-piece injection molded ULTEM® High Performance Polymer composite. Fully-adjustable swivel arm with vibration-proof locking teeth. Fasteners are 300 series stainless steel. 1/2" NPS male threads to screw onto accessory mounting stake or junction box, sold separately.

FINISH:

Composite is textured, pressure formed, molded-in-color.

OPTICAL ASSEMBLY:

Lens is a clear polycarbonate shield.

LAMPING:

20W maximum T3 bi-pin lamp. Lamp is included with fixture. Lower wattage lamps are acceptable.

ELECTRICAL ASSEMBLY:

Bi-pin socket type (G4) with 250° C high temperature teflon coated wire leads. 12 Volt fixture is pre-wired with 3-ft pigtail of 18-2 AWG, 105° C, SPT-1W wire. Low voltage quick connector, catalog #LVC3 included for easy hook-up to the low voltage supply cable, not included. 12 Volt system requires remote transformer, not included.

WARRANTY:

Ten-year limited warranty.

CERTIFICATIONS:

ETL listed to U.S. safety standards for wet locations. cETL listed to Canadian safety standards for wet locations. Manufactured to ISO 9001:2008 Standards.

Height :

7 1/4" (184mm)

Width:

5 3/8" (137mm)

Depth:

2 5/8" (67mm)

Max. Weight:

1.2 lb