



© 2015 Pure Lighting. All Rights Reserved.

Installation Instructions For Reveal Light Channel

1718 W. Fullerton Ave
Chicago, IL 60614
Tel: 773-770-1195
Fax: 773-935-5613
www.purelighting.com
info@purelighting.com

IMPORTANT INFORMATION

- Reveal channel can be used as a toe kick or for cove lighting.
- This instruction shows a typical installation.

SAVE THESE INSTRUCTIONS!

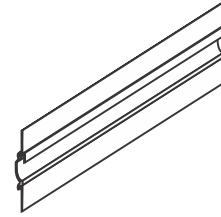

Install the Junction Box (C-1RE-JBOX)

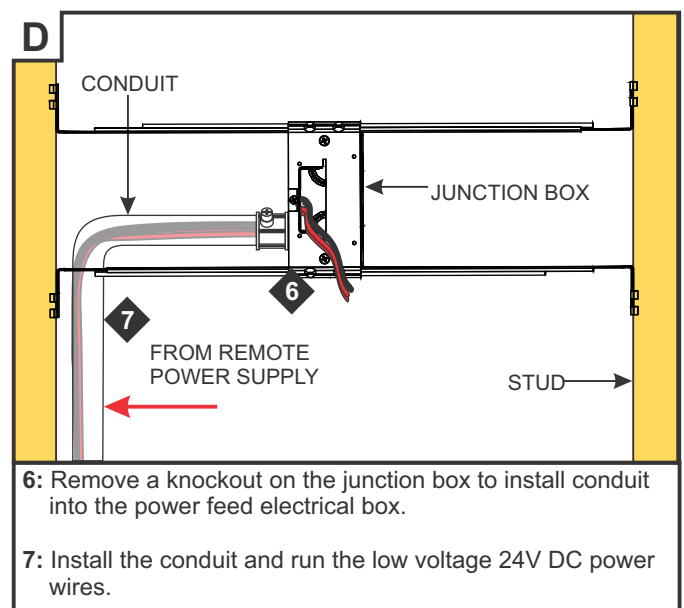
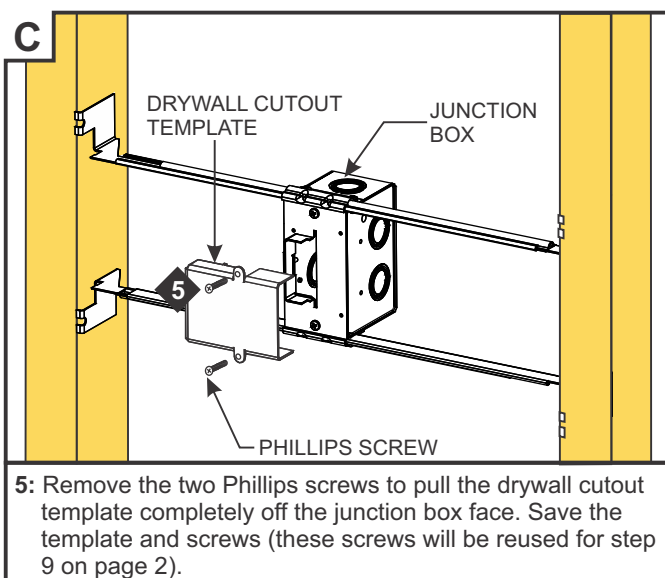
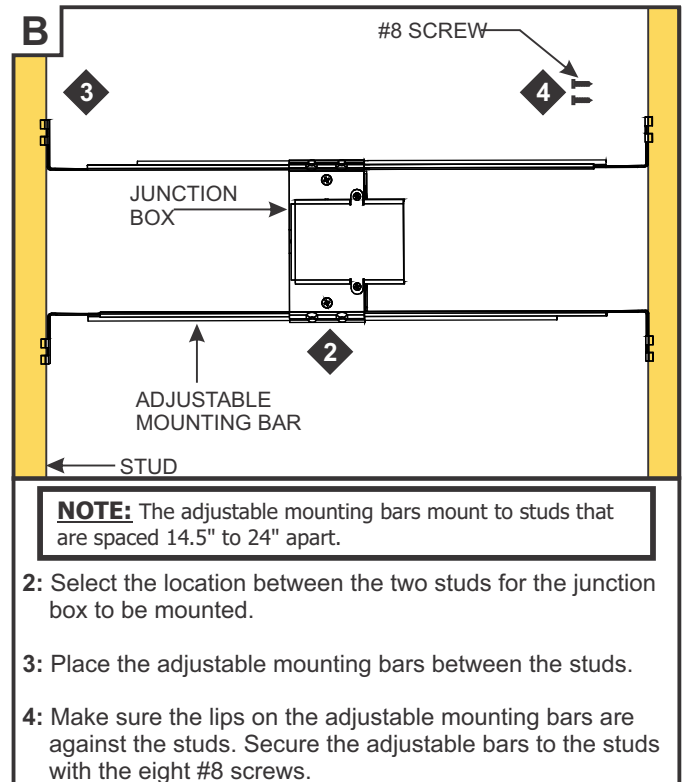
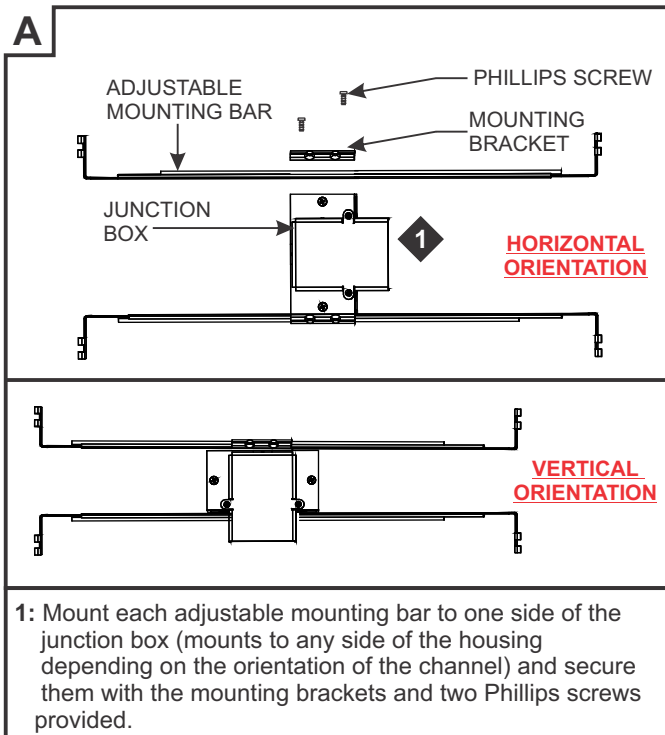

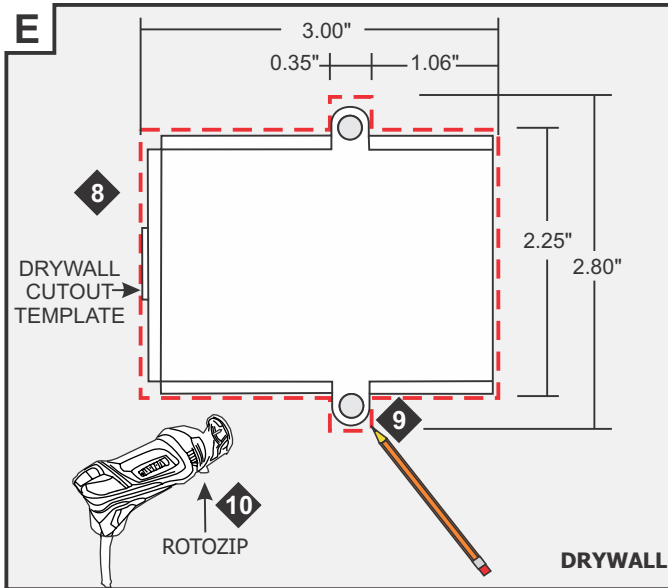

- 8:** Mark a location on the drywall where the junction box will be located.
- 9:** Trace the drywall cutout template onto the drywall at the junction box location.
- 10:** Remove drywall cutout template and cut out the marked area using a "Rotozip" tool.

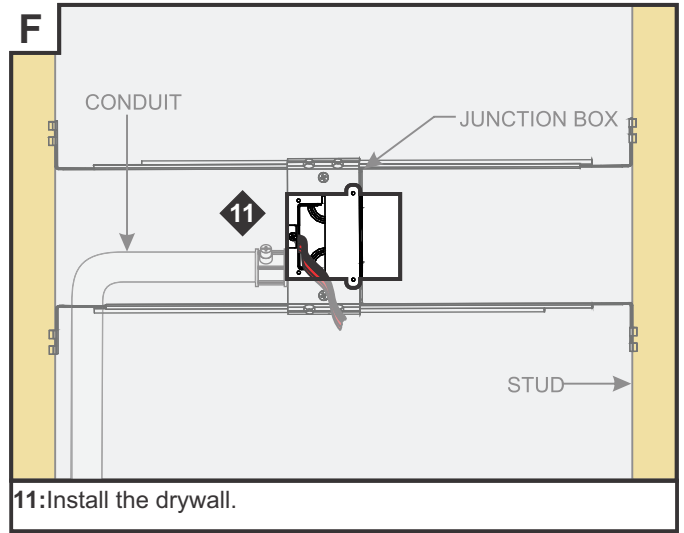

11: Install the drywall.

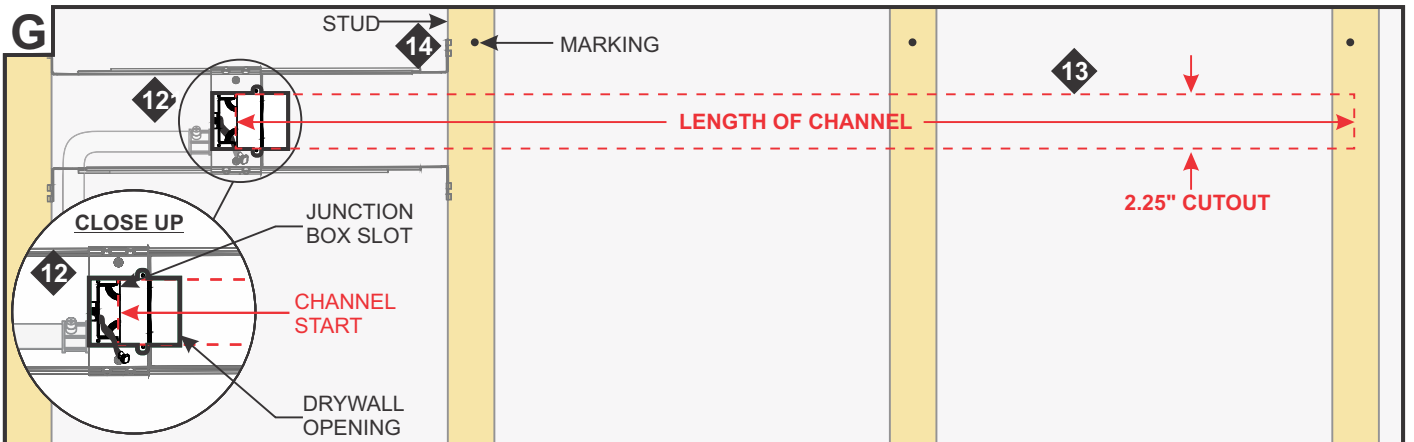

- 12:** Using the drywall opening as reference, mark 2.25" wide lines the complete length of the channel along the drywall.
- 13:** Cut out the mark line on the drywall.

14: Mark the location to the studs for future reference.

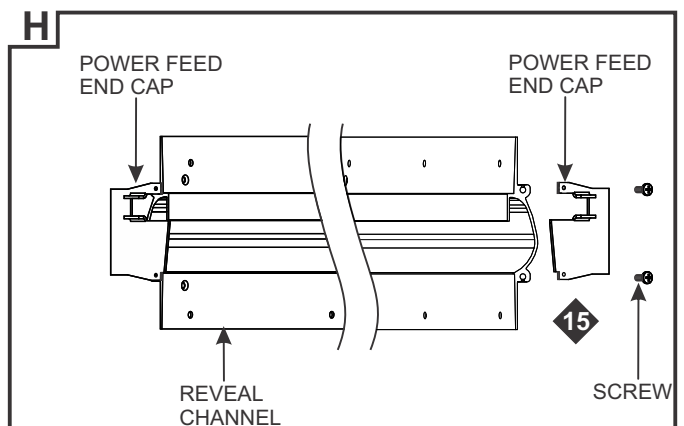

15: Remove one included power feed end cap from the channel end opposite the junction box.

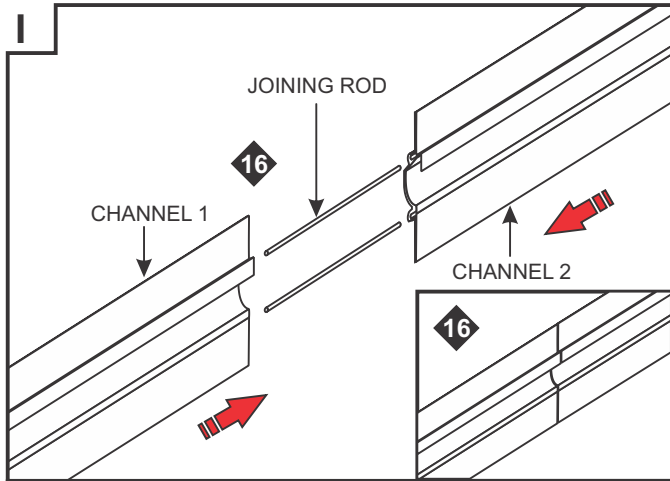

NOTE: Channel may be cut in the field. For installation over 120" join two or more Reveal channels together shown on diagram B
NOTE: It is recommended more than one person to install the Reveal channel.

16: OPTIONAL: Insert the joining rods half way into the each channel circular ends sliding them towards each other.

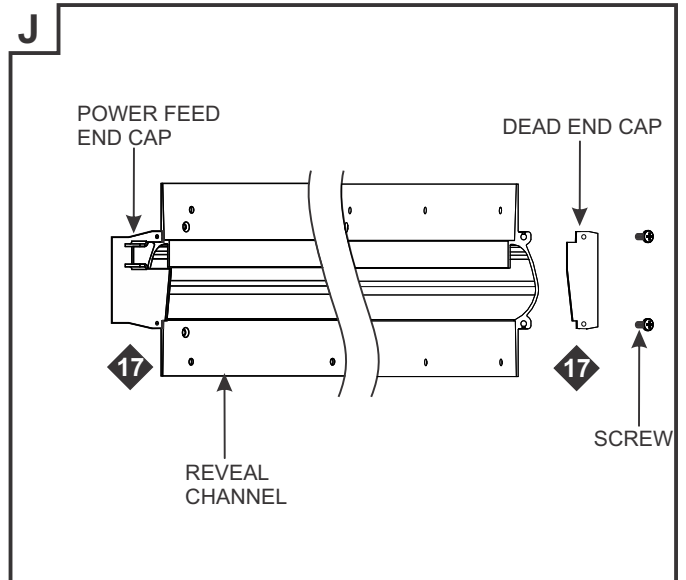

17: Install the dead end cap to the end of the channel opposite the junction box.

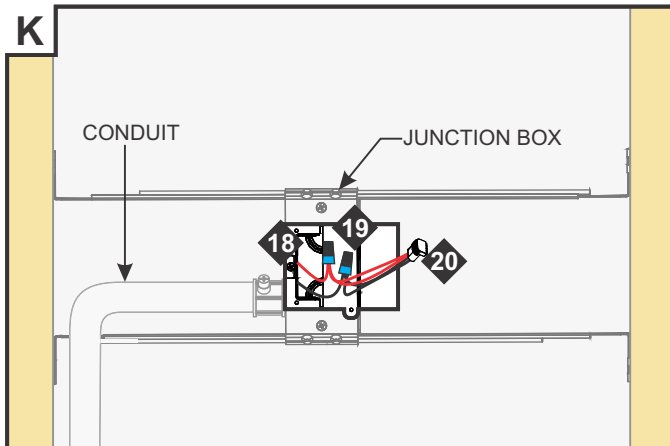

18: Connect the red power supply (24VDC+) wires to each red power wire with a wire nut inside the electrical box.

19: Connect the black power supply (24VDC-) wires to each black power wire with a wire nut inside the electrical box.

20: Place the wire nut connections inside junction box.

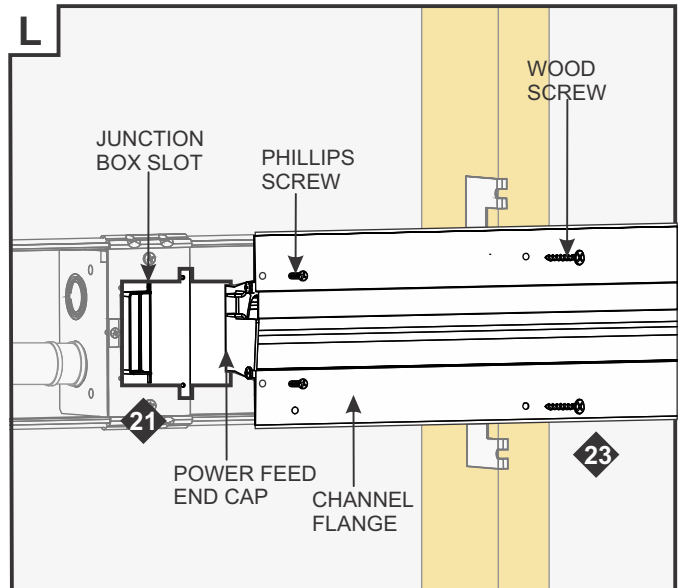

21: Align the power feed end cap into the junction box opening slot and push channel into the drywall cutout.

22: Make sure channel is aligned straight using a laser level.

23: Insert the power feed end cap into the junction box slot and align the channel to the drywall cutout. First secure the channel using the two Phillips screws to the junction box (same screws as in step 5 page 1) followed by fastening the drywall screws through the pre-drilled holes onto the studs.

If necessary drill new holes on channel flange where they line up with the studs using the #6 X 1-5/8" square trim screw with the square recess bit provided.

NOTE: Make sure screw head is flush with the channel flange.

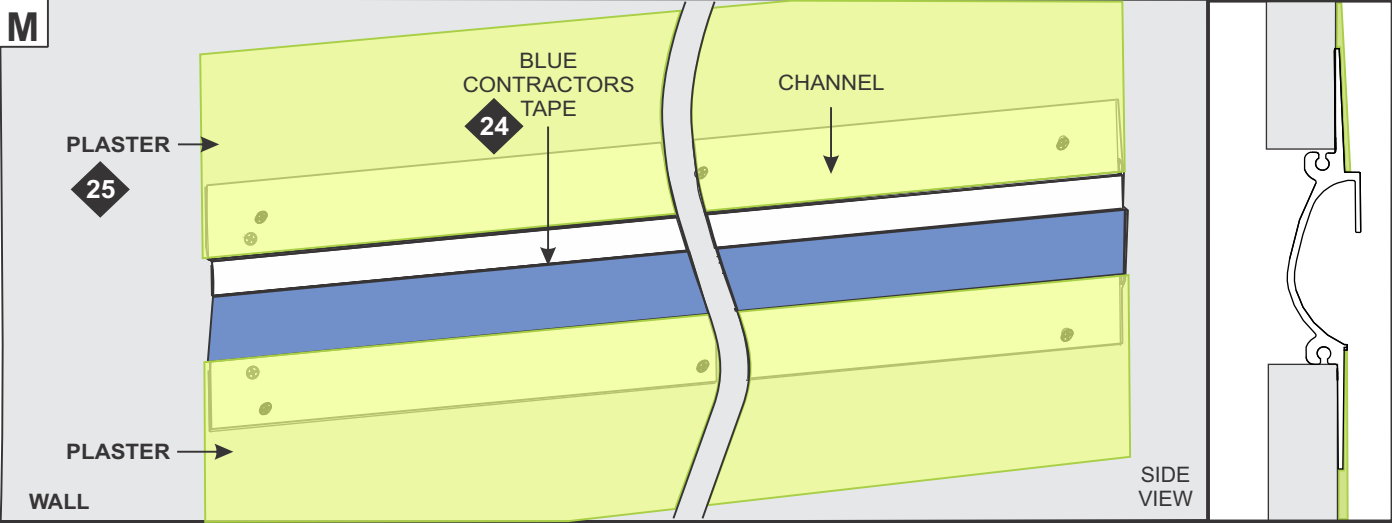

24: Cover up the opening section of the Reveal channel with contractors blue tape to prevent plaster and dust entering inside the channel.

25: Plaster the channel flange edge to the wall & fill screw holes (highlighted in green). Finish the wall properly.

26: Remove the blue contractor tape & clean the inside of the channel.

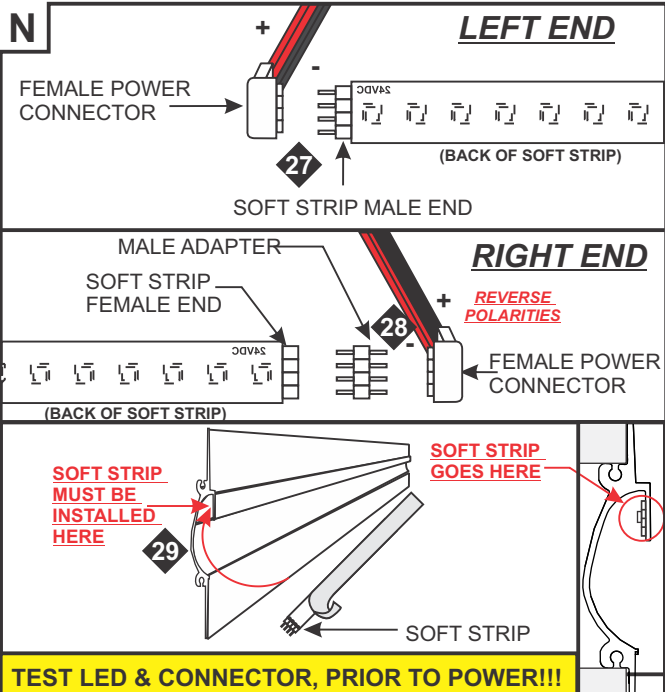

TEST LED & CONNECTOR, PRIOR TO POWER!!!

27: If the male end of the soft strip is facing the power electrical box, then connect the female power connector to the male soft strip connector so that the red wires of the power connector are inline with the "+24VDC" marking of the soft strip.

28: If the female end of the soft strip is facing the power electrical box, then connect the male adapter to the female soft strip and power connector so that the black wires of the power connector are inline with the "+24VDC" marking of the soft strip.

29: Remove the backing from the soft strip and installed it inside the channel. Make sure that the soft strip is firmly attached to the channel.

30: After trimming the soft strip on cuttable section, place the excess soft strip behind the drywall

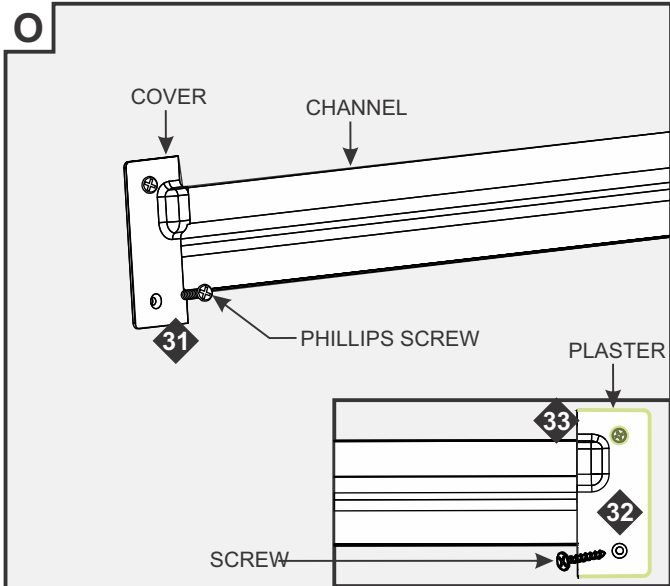

31: Make sure all wire connections are inside the junction box and install the electrical box cover with the provided two screws.

32: OPTIONAL: For the other side of the channel, extra cover is included that can be mounted to the drywall using drywall screws to secure in place.

33: OPTIONAL: For cleaner finished look apply plaster over screw holes and end cap edges.

GENERAL WIRING DIAGRAM

