



Installation Instructions For TruLine .5A and 1A TruQuad



1718 W. Fullerton Ave
Chicago, IL 60614
Tel: 773-770-1196
Fax: 773-883-6128
www.purelighting.com
info@purelighting.com

© 2016 Pure Lighting. All Rights Reserved.

IMPORTANT INFORMATION

- This product is wall or ceiling mount.
- This instruction shows a typical installation.
- This product is ETL listed for indoor use.

SAVE THESE INSTRUCTIONS!

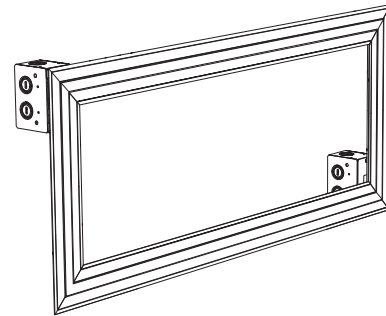

Pre-installation Guide

1: Depending on the size of the TruQuad, identify the design layout based on the 4 possibilities below.

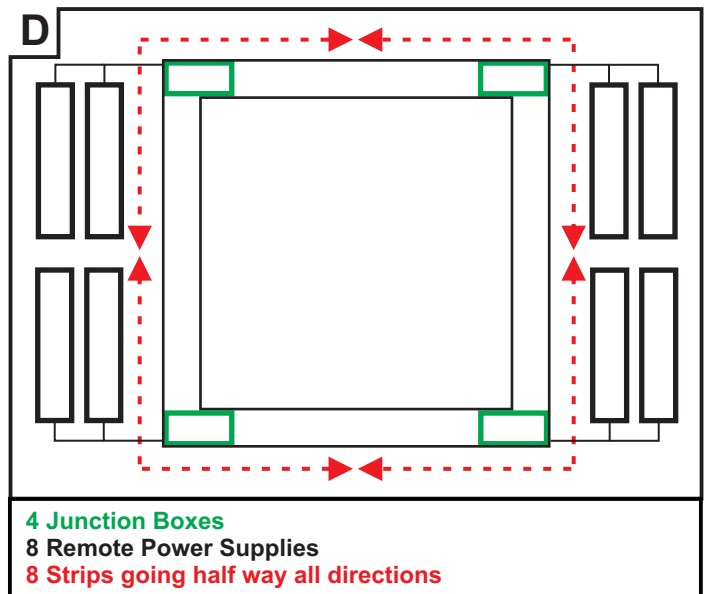
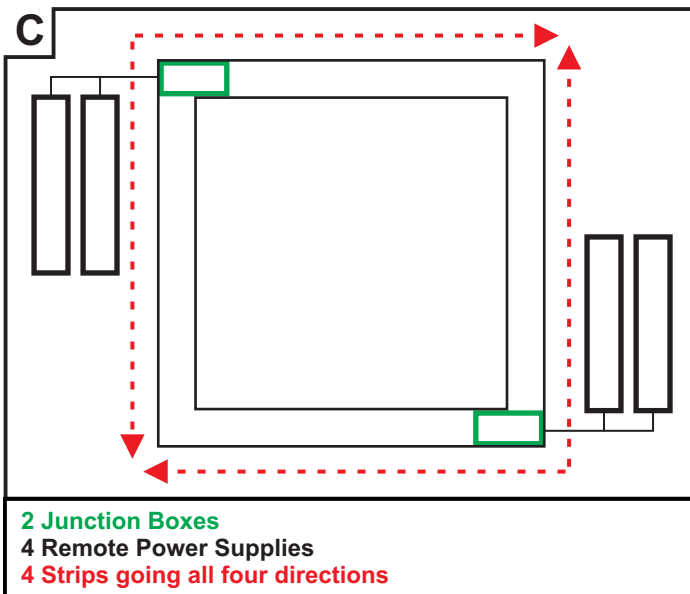
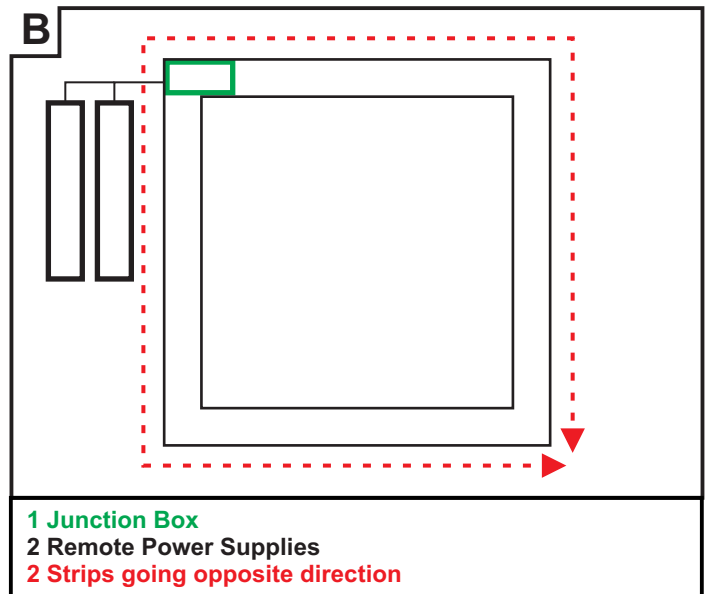
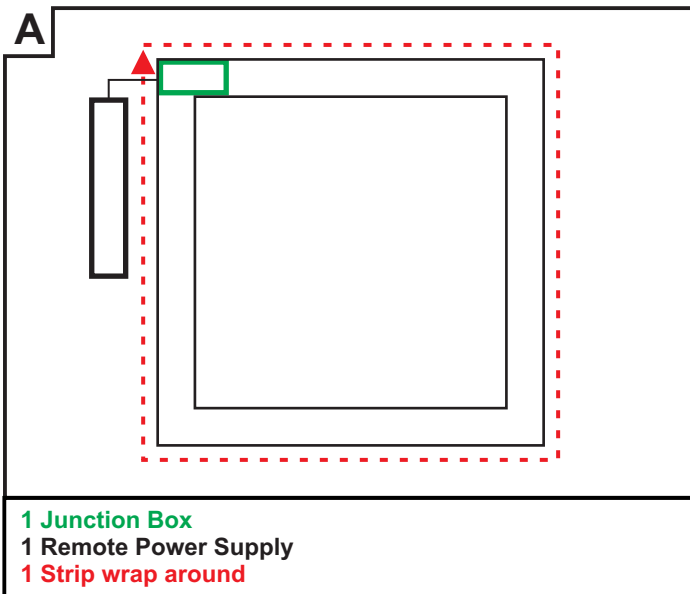

Included Components

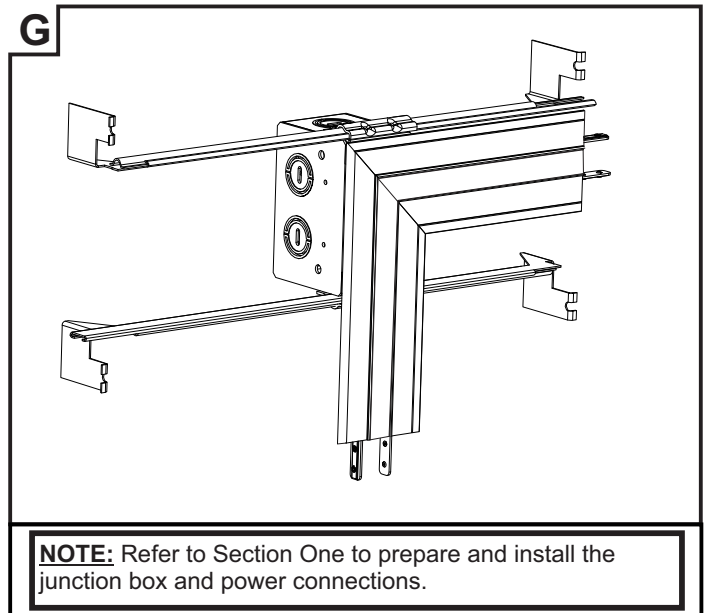
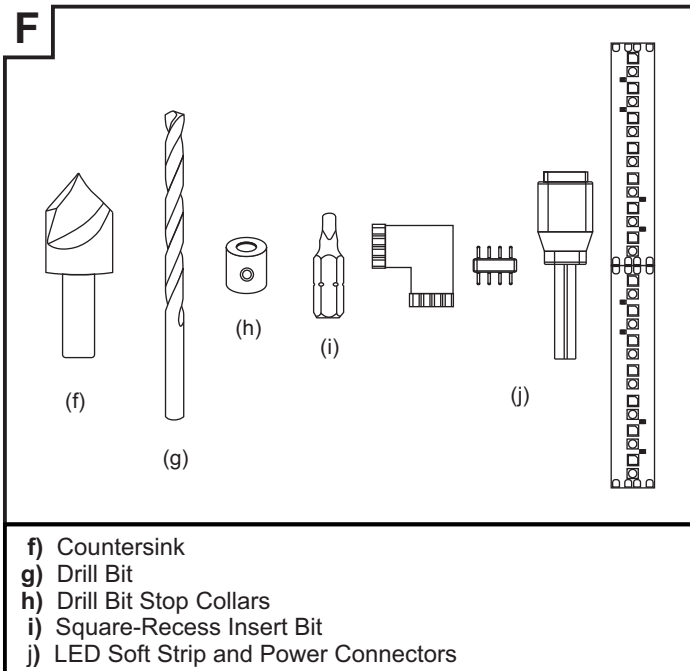
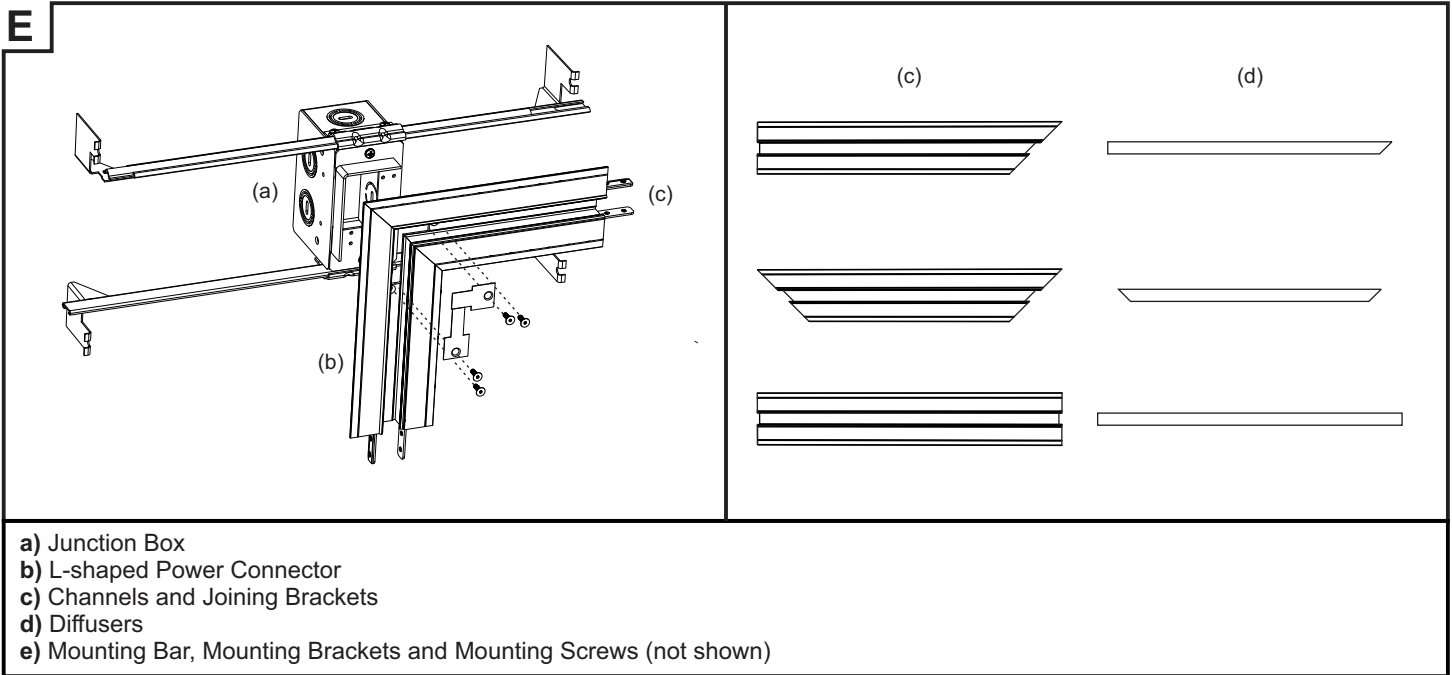

Section One: Prepare and Install Junction Box and Power Connections

H

JUNCTION BOX

#6-32 PHILLIPS SCREW

TRAP DOOR

1

1: Remove the #6-32 screws from the junction box to remove the trap doors from the assembly.

I

#6-32 PHILLIPS SCREW

L-POWER CONNECTOR ASSEMBLY

2

2: Remove the #6-32 screw from the junction box to remove the L-Power Connector assembly.

J

JUNCTION BOX

ADJUSTABLE MOUNTING BAR

PHILLIPS SCREW

MOUNTING BRACKET

3

3: Mount each adjustable mounting bar to one side of the junction box and secure them with the mounting brackets and two Phillips screws provided.

K

STUD WALL

4

4: Measure and locate junction box to desired location. Determine the corner that the junction box will be installed to. Longer installation lengths may require two (opposing corners) or four (all corners) junction boxes.

L

STUD

ADJUSTABLE MOUNTING BAR

JUNCTION BOX

CONDUIT W/ LOW-VOLTAGE WIRES

5

6

NOTE: The adjustable mounting bars mount to studs that are spaced 13" to 24" apart.

5: Place the lips on the adjustable mounting bars against the studs. Secure the adjustable bars to the studs with the eight #8 screws.

6: Install power supply (reference installation instructions included with power supply) and conduit (if required by local electrical code) and run low-voltage power wires to the junction box.

M

JUNCTION BOX

POWER WIRE

7

8

7: Connect the red power supply (24VDC+) wires to the red power connector wires with a wire nut.

8: Connect the black power supply (24VDC-) wires to the black power connector wires with a wire nut.

9: Place the wire nut connections inside junction box.

NOTE: Test the LED soft strip to ensure it is working properly. Take out the LED soft strip for later use.

Section Two: Prepare Drywall and Install Channel

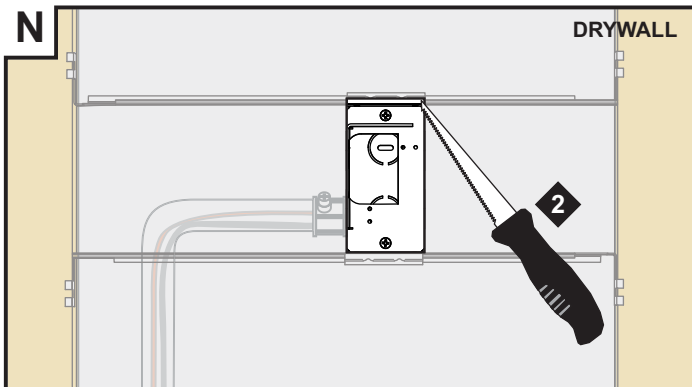

1: Install drywall.

2: Using location measurements from previous steps, mark the drywall and cut a section where the junction box will be located using a 6" fixed jab saw or other appropriate tool.

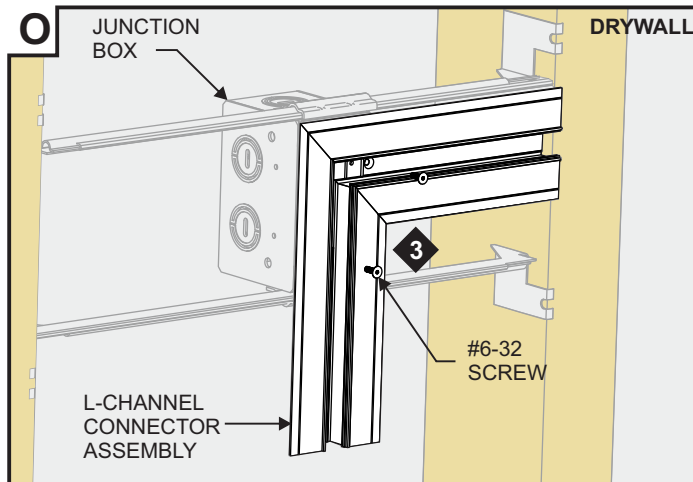

3: Attach the assembled L-Channel Connector to the junction box using a #6-32 screw.

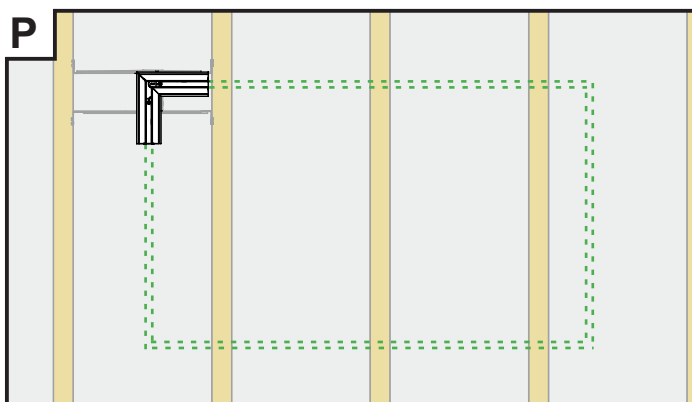

4: Mark the installation location on the drywall using a pencil or chalk line before cutting 1.05" wide.

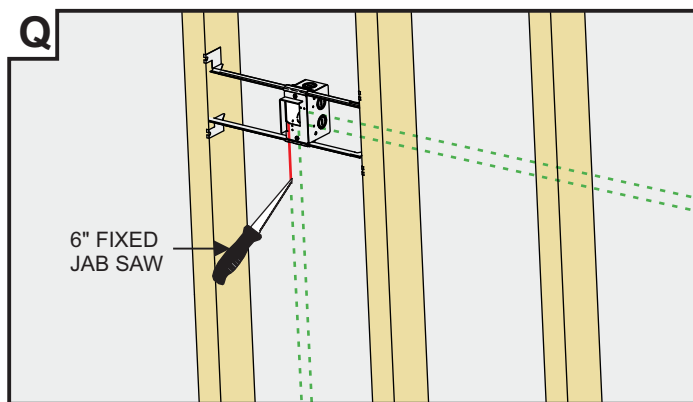

5: Remove the L-Channel Connector before cutting.

6: Cut the drywall along the marked installation path using a jab saw or other appropriate tool.

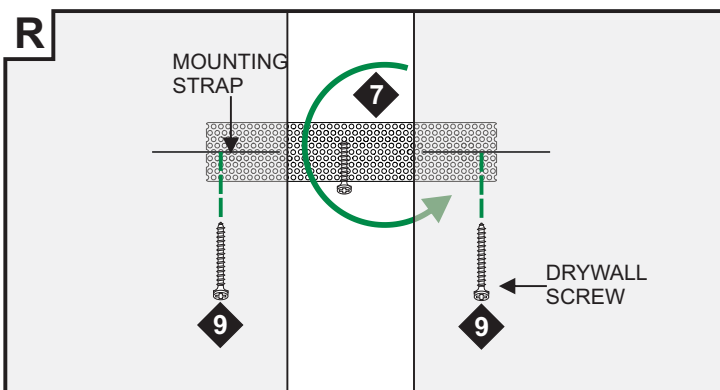

7: Install mounting straps behind the drywall where studs are not available (suggested spacing is every 32") by threading a drywall screw into the perforated material.

8: Place the mounting strap behind the cut drywall and rotate into place using the drywall screw as a handle.

9: Secure the mounting strap to the drywall using two drywall screws.

10: Mark the location of the studs and mounting straps on the drywall.

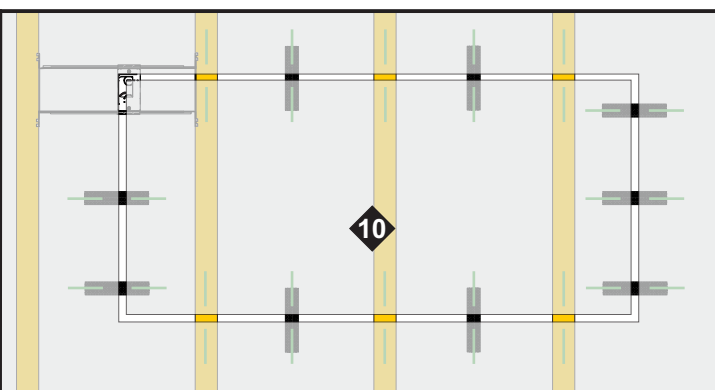

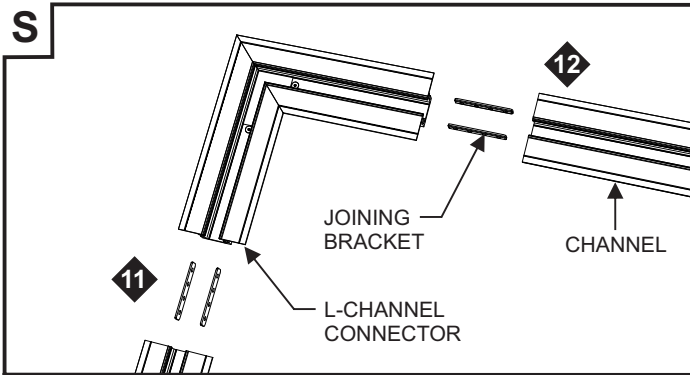

11: Insert joiner bars halfway into the L-Channel Connector. Tighten the M4 set screws on each joiner bar with a 1.5MM Allen wrench.

12: Slide the other section of channel onto the joining bars and tighten the remaining M4 set screws with a 1.5MM Allen wrench.

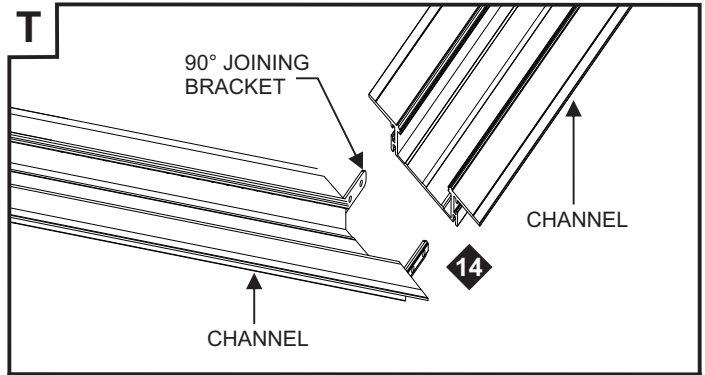

13: Insert a 90° joiner bracket halfway into one mitered channel corner. Tighten the two M4 set screws on each joiner bar with a 1.5MM Allen wrench.

14: Slide the other section of mitered channel onto the 90° joining brackets and tighten the remaining M4 set screws with a 1.5MM Allen wrench.

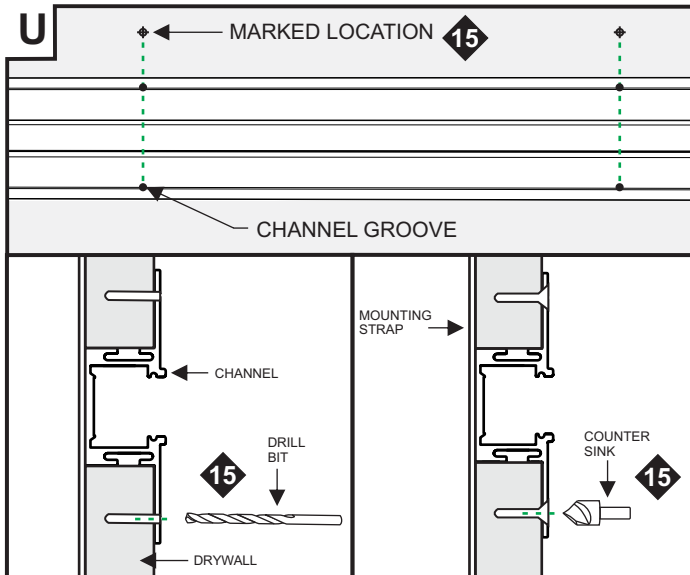

15: Place the assembled channel to the drywall cutout. Using the marked locations on the drywall, drill and countersink the channel using the provided square drill with counter sink bit.

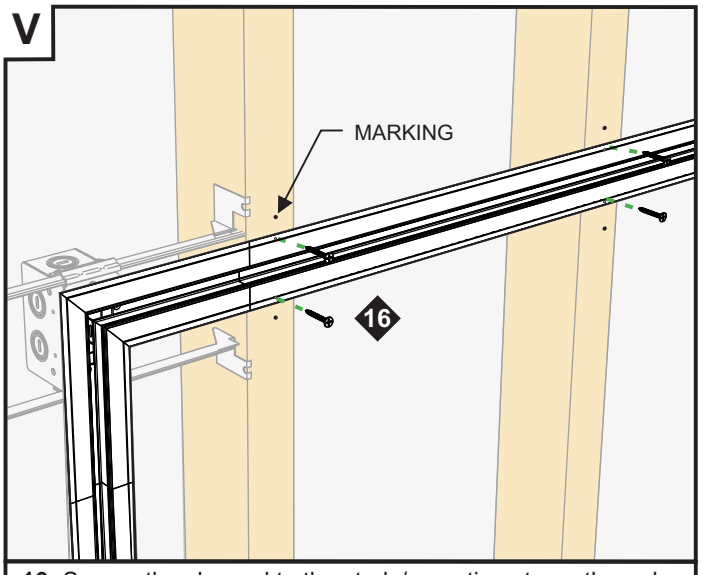

16: Secure the channel to the studs/mounting straps through the drywall with the #6 screws using the provided square recess bit.

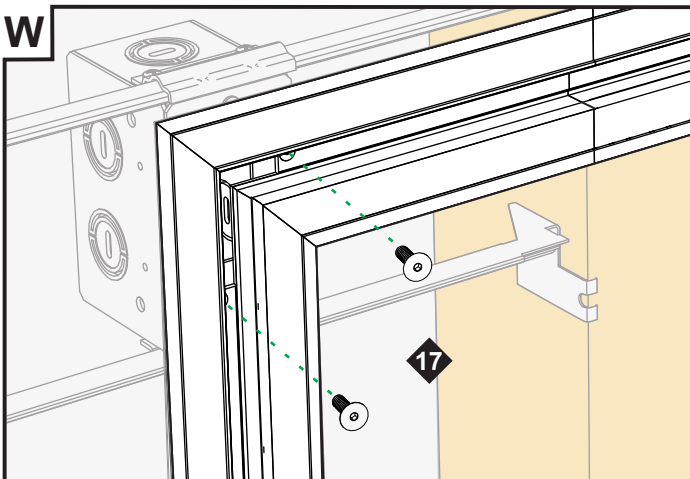

17: Secure the L-Connector to the junction box with the supplied screw.

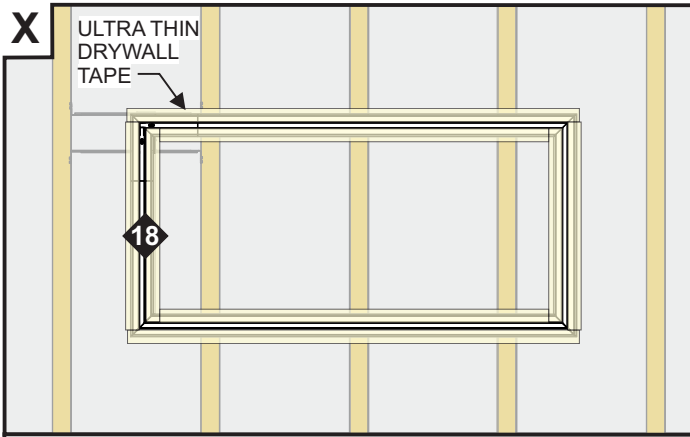

NOTE: Test the LED strip before any plaster work is done.

18: Apply ultra-thin drywall tape along edges of channel to prevent cracking of plaster after installation. **DO NOT OVERLAP DRYWALL TAPE!**

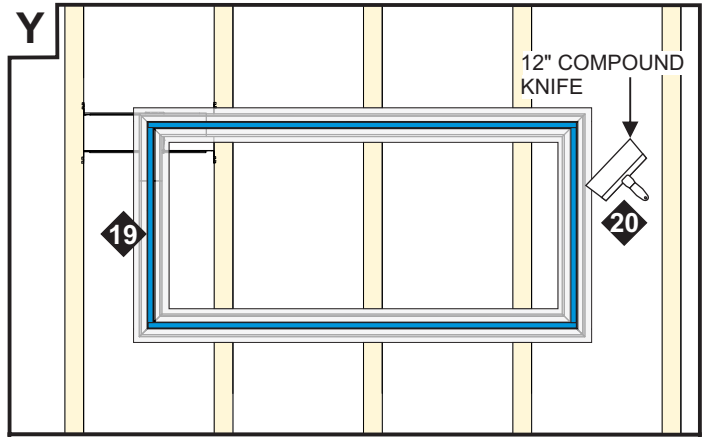

19: Mask the interior surfaces of the channel using blue contractor's tape before plastering and painting.

20: Use a 12" compound knife for a smooth compound spread. Sand, paint, and finish the plaster and drywall before removing the blue contractor's tape.

Section Three: Install Soft Strip and Lens

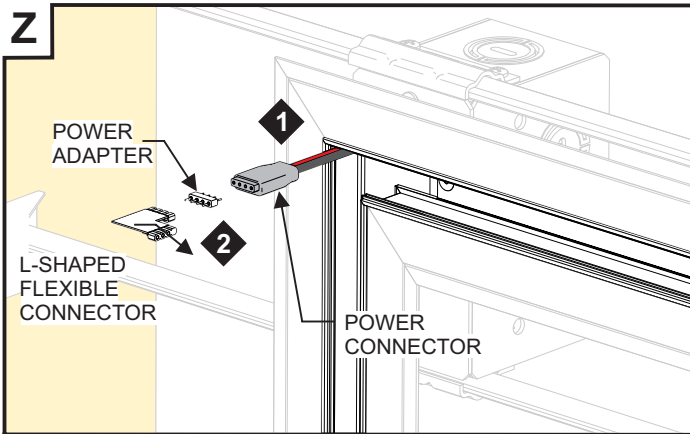

1: Insert the male-to-male power adapter to the power connector.

2: Connect the L-Shaped Flexible Power Connector to the male-to-male power adapter.

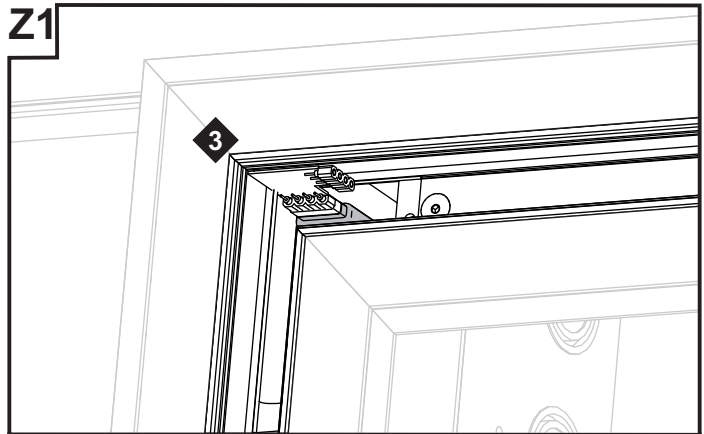

3: Place the assembled power connection into the channel where the LED strip will be installed.

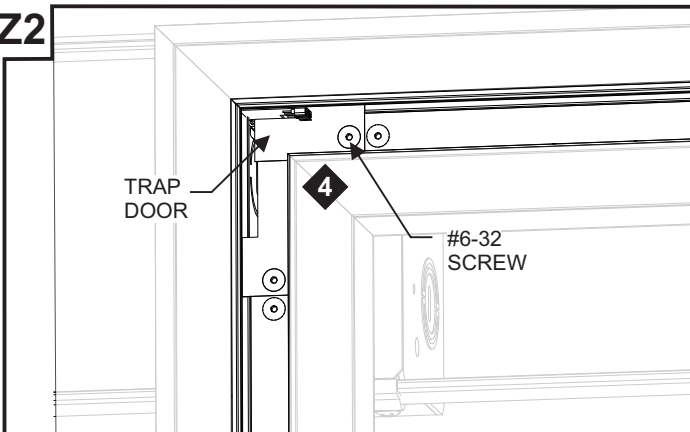

4: Replace the trap doors and secure using the #6-32 screws.

5: If necessary (depending on design), repeat step 1 through 5 for other corners.

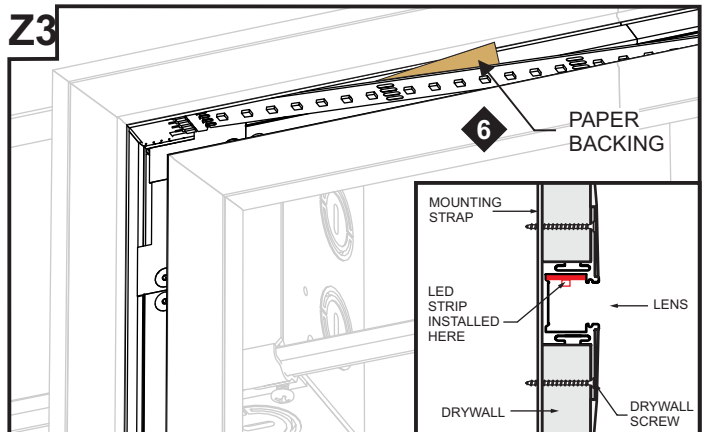

6: Carefully remove the backing from the LED soft strip, making sure not to remove the tape from the soft strip. Line up the red wire side of the power connector with the "+24VDC" marking on the Soft Strip. Push the male connector of the Soft Strip into the L-Shaped Flexible Power Connector.

IMPORTANT INFORMATION REGARDING INSTALLATION AND REWORK OF SOFT STRIP LED

DO gently pull up and away from the soft strip if removing to reposition. This avoids damaging the strip.

DO NOT pull the strip back towards itself. Doing so risks damaging the strip and making it not function.

DO only ever use fingers to gently install soft strip to a surface **AFTER** cleaning the surface with alcohol.

DO NOT use any tool to install soft strip to a surface. This will damage the soft strip component.

Relocating Soft Strip (Optional)

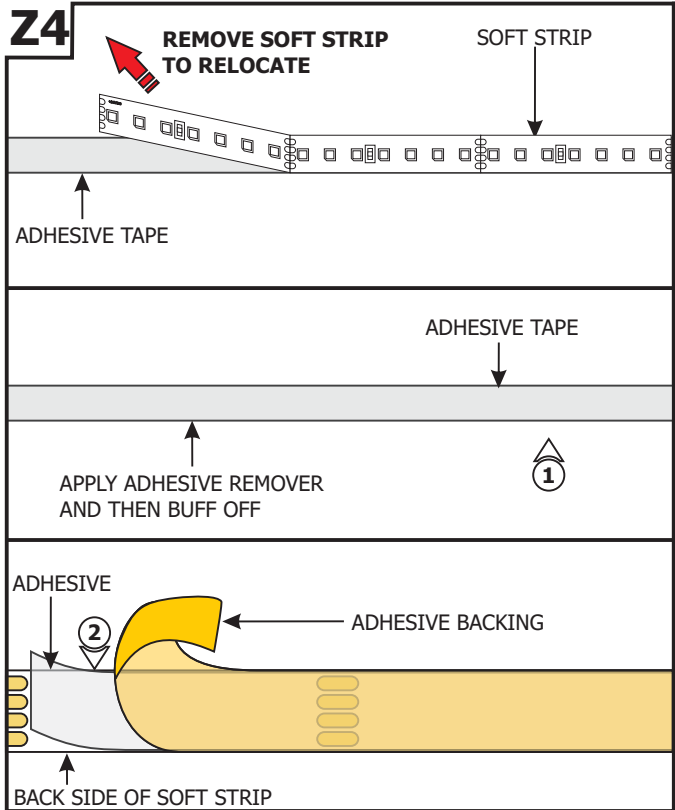

NOTE: If relocating the installed soft strip, make sure that the adhesive tape on back of the soft strip covers the entire strip. The adhesive tape isolates the strip from the installation surface. Damaged or inconsistent adhesive tape may cause the contacts on the back of the strip to come in contact with the conductive heat sink which will cause the strip to short and burn. Call Edge Lighting to get replacement adhesive tape and/or optional aluminum heat sink tape (SS-HR-F)

- 1:** To remove tape residue from back of the strip, apply WD-40, Goo Gone, or a mixture of warm water and lemon oil to the corner of a clean, dry towel. Gently buff the area containing the adhesive residue until it is completely removed.
- 2:** Gently remove a few inches of the from one side of the tape backing. Attach the adhesive tape to the back of the soft strip and apply moderate pressure to affix the tape. Continue this step a few inches at the time until the entire adhesive tape is attached to back of the soft strip.
- 3:** Refer to the steps on 6 through 9 to reinstall the soft strip.

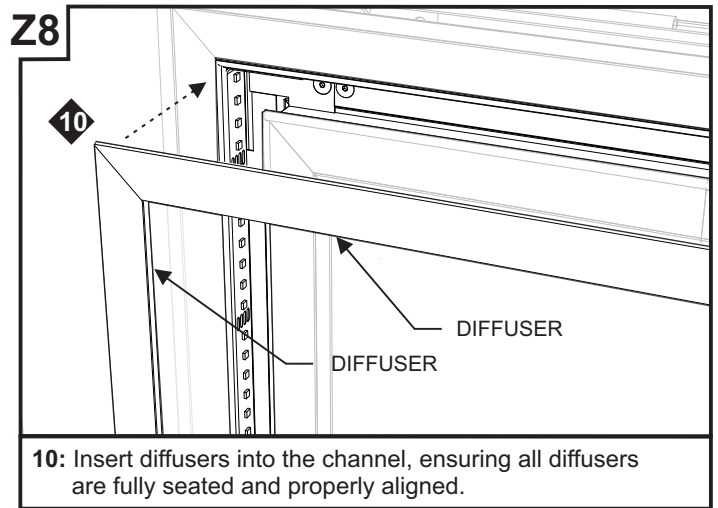
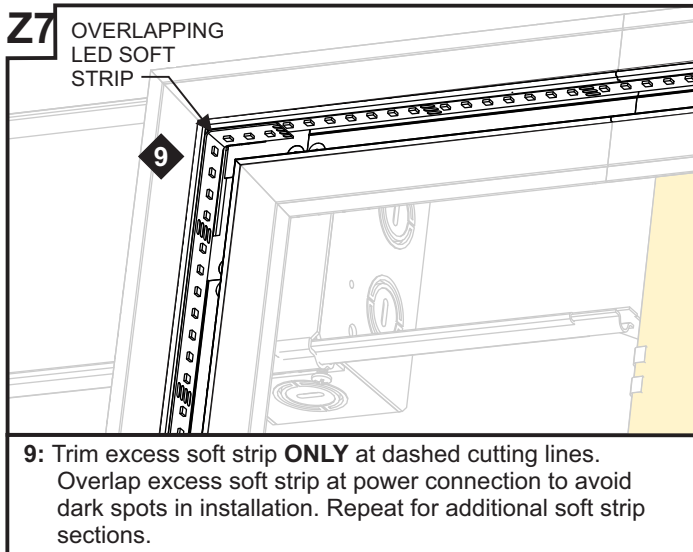
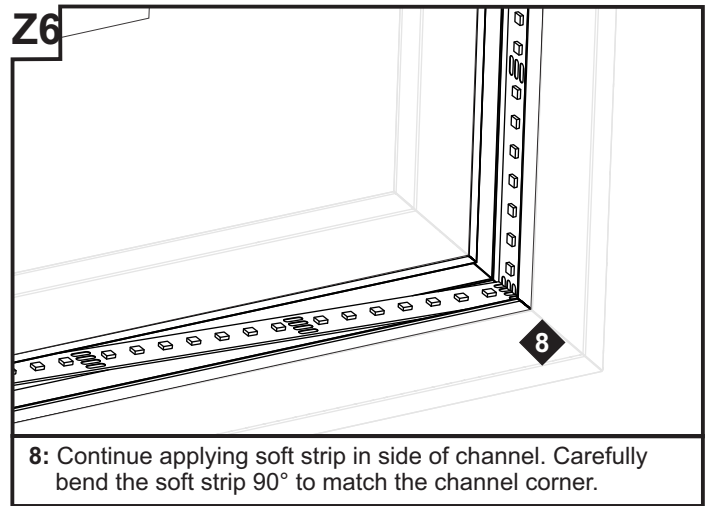
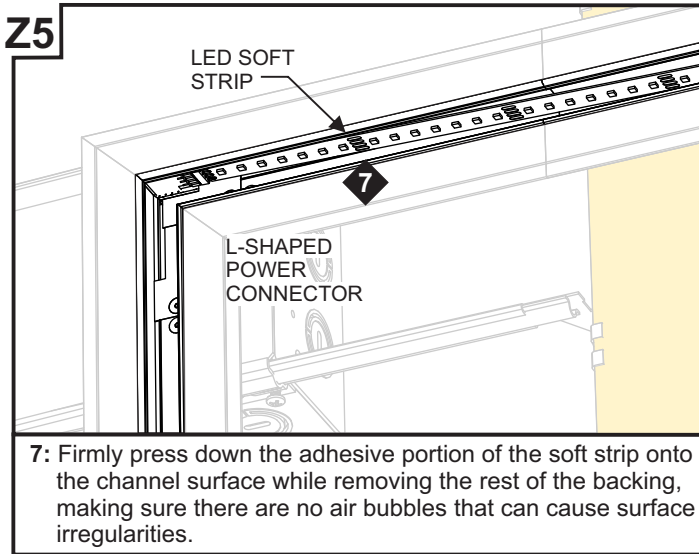

Section Six: Wiring Diagrams

General 24VDC Configuration

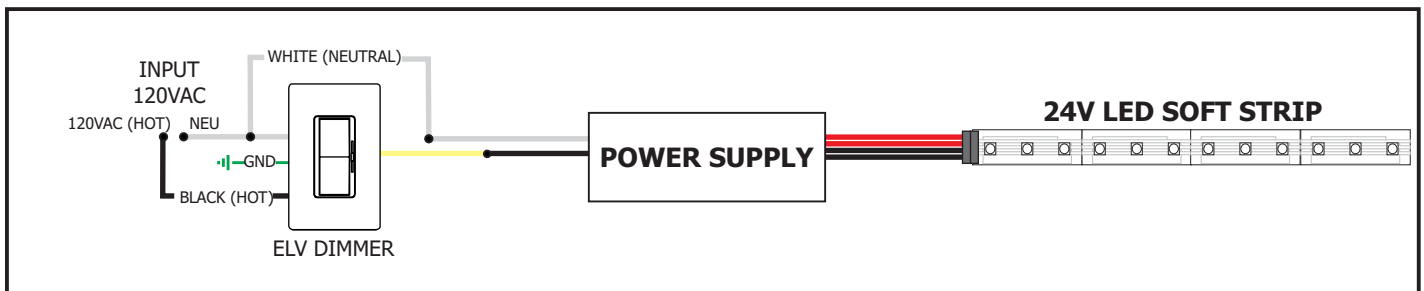

Standard RGB Configuration

Using LED Power Supply with RGB Soft Strip & CDP or CTP Control

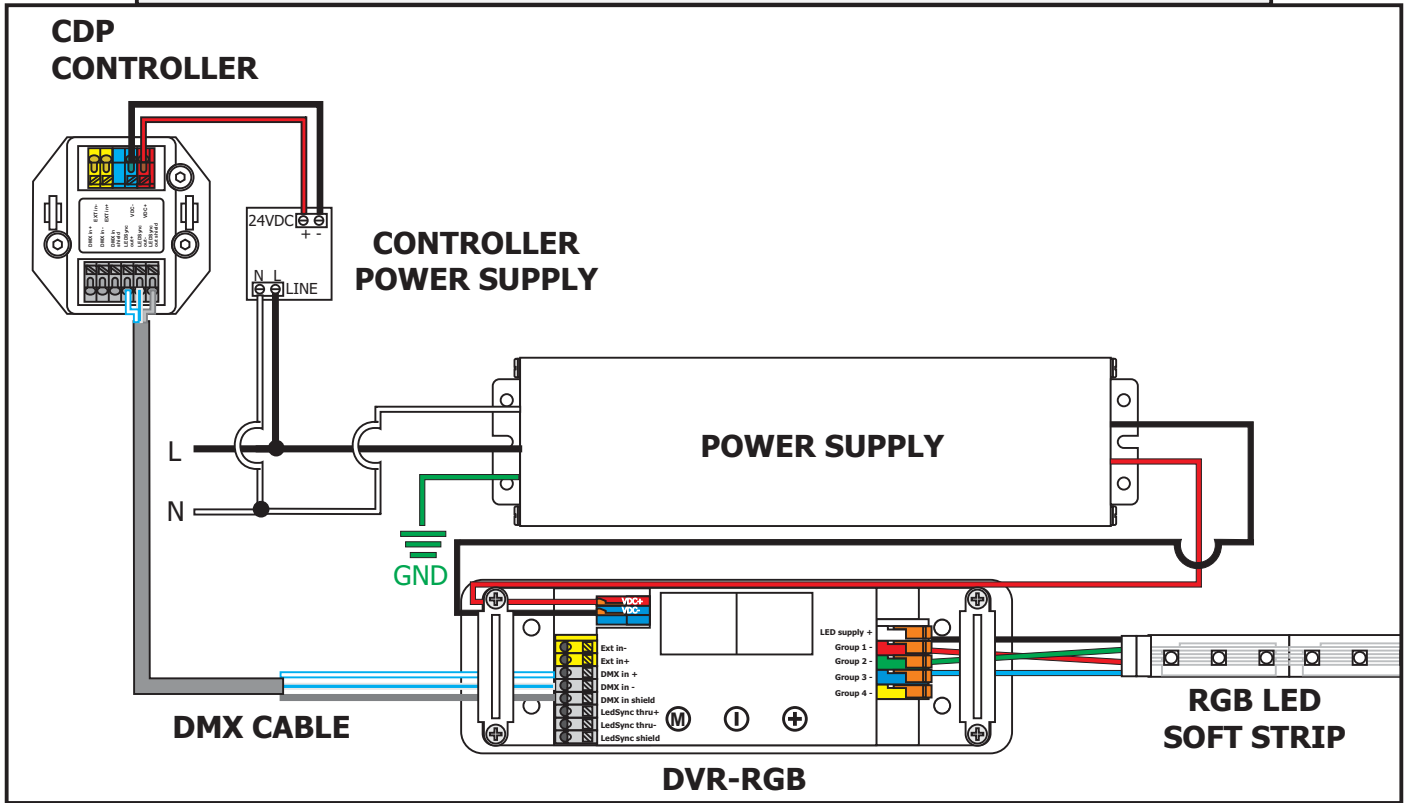

RGB+W Configuration

Using LED Power Supply with RGB+W Soft Strip & CDP or CTP Control

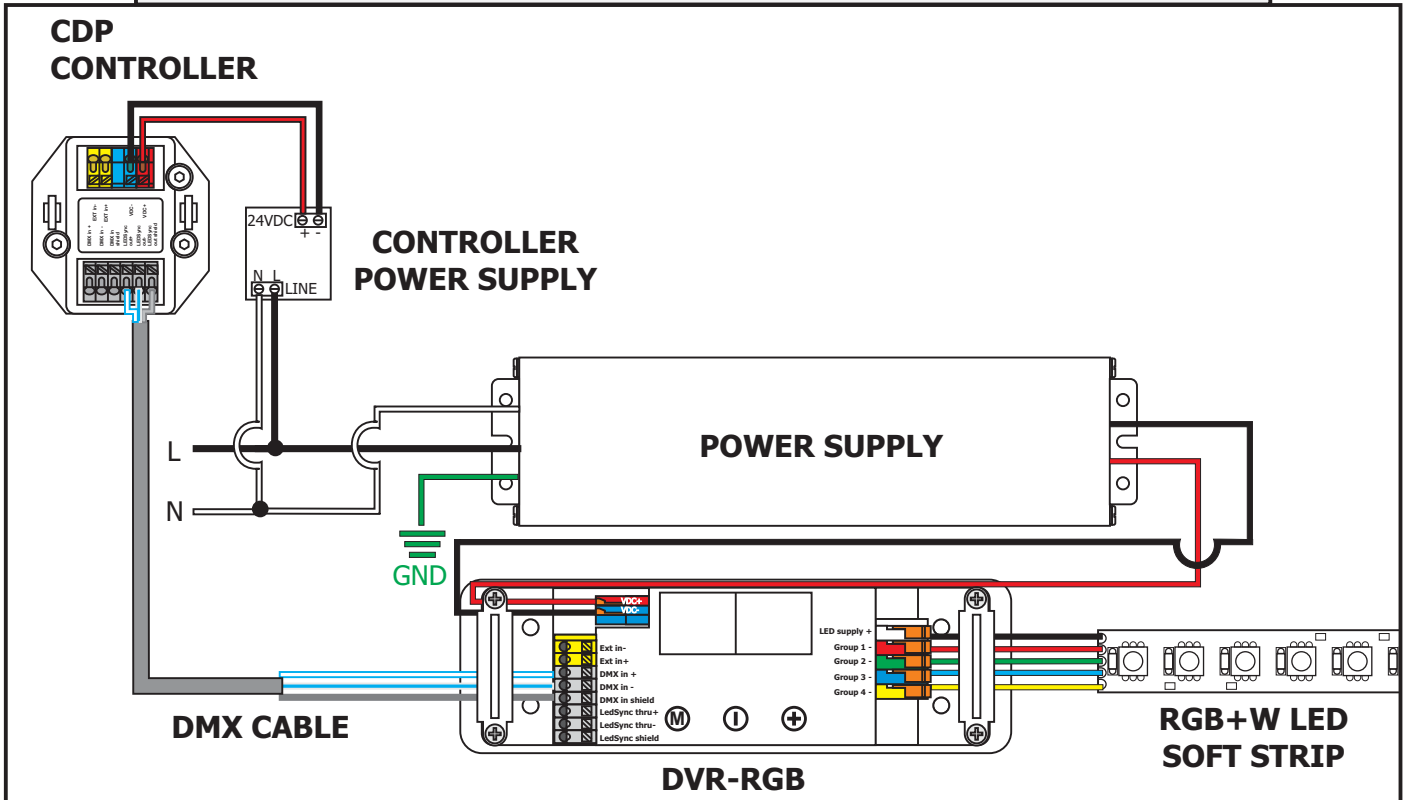

Tunable White Configuration

Dual Power Supplies Controlled Via Individual ELV Dimmers

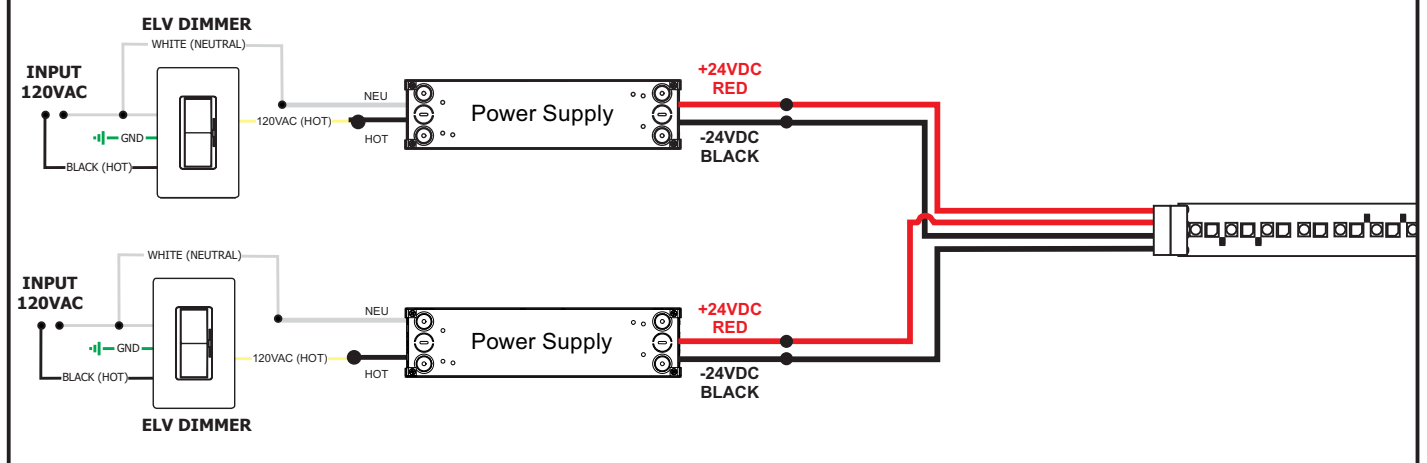

RGB Power Supply with DMX Controller

