



BRAND

ConTech

DESCRIPTION

RL530 5 Inch New Construction Non-IC Housing is designed for non insulated new construction installations. Non-IC designation requires that insulation be kept a minimum of 3 inches away from housing. One 120 volt, PAR30, BR30, R20, PAR20 or A-type medium base halogen bulb or LED equivalent is required, but not included. Lamp type and wattage dependent on housing/trim combination (see attached manufacturer specification). Halogen and incandescent dimmable with a standard incandescent dimmer. Consult bulb manufacturer for dimmer compatibility when using LED equivalent bulb option. cULus listed. Suitable for damp locations. 8 inch width x 11.5 inch length x 7 inch height. A complete fixture includes a housing and trim, sold separately.



TRIM COLOR	N/A
BODY FINISH	Aluminum
WATTAGE	75W
DIMMER	Dimmable
DIMENSIONS	11.5"L x 8"W x 7"H
BULB NOT INCLUDED	
LAMP	<ul style="list-style-type: none"> PAR30/Medium (E26)/75W/120V Halogen 1 x BR30/Medium (E26)/65W/120V Incandescent 1 x A19/Medium (E26)/75W/120V Incandescent 1 x PAR20/Medium (E26)/50W/120V Halogen 1 x R20/Medium (E26)/50W/120V Incandescent

Technical Information

CEILING TYPE	Drywall with Trim
HOUSING TYPE	New Construction NON IC
HOUSING HEIGHT	7"

SPEC # CNT24457

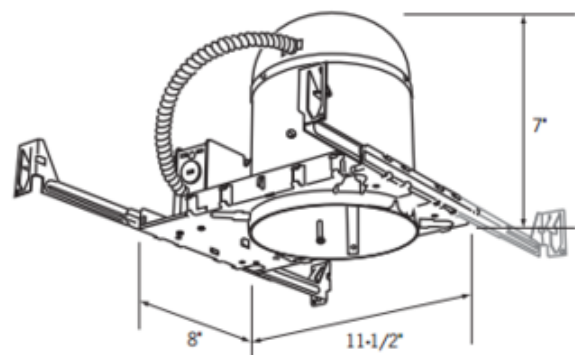

Ceiling Opening: 5-3/4"

COMPANY	PROJECT	FIXTURE TYPE	APPROVED BY	DATE