

About Hammerton Studio

HAMMERTON STUDIO

When we introduced the Hammerton Studio brand in 2014, we saw an enormous opportunity to raise the bar in decorative lighting. In design, we wanted to lead rather than follow. In construction, we wanted to showcase Hammerton's renowned reverence for time-honored artisan craftsmanship and authentic materials. In performance, we wanted to provide highly reliable solutions that far exceeded industry norms for aesthetics, function, and quality. Based on the brand's dramatic growth and customer feedback, it's clear we are on the right track.

EXTRAORDINARY DESIGN VALUE IN ARTISAN GLASS & METALWORK

Hammerton began in 1995 as a blacksmith shop, but we've come a long way since then. Today we employ a world class team of metal artisans who are disciplined in a broad range of fabrication techniques and processes. We've also added in-house capabilities in blown, cast and kiln-fused glass, and today Hammerton operates one of the largest artisan glass production facilities in the U.S. With deep design and fabrication expertise at the intersection of glass and metalwork, we're laying the foundation for a new era of lighting innovation.

THE HAMMERTON HERITAGE

Our Hammerton Studio brand stands on the shoulders of more than a quarter century of experience pushing the boundaries of innovative custom lighting design. Each Hammerton Studio collection has been inspired by custom work our company has brought to life in collaboration with leading interior design professionals over the years. Built to your specifications, every fixture reflects the uncompromising design and attention to detail that is distinctly Hammerton.

A REPUTATION REFLECTED BY OUR CLIENTS

Hammerton fixtures are as extraordinary as the clients who purchase them, including Forbes 400 members, Fortune 500 leaders, award-winning entertainers, fashion and interior designers, sports legends, and leading luxury hospitality brands.

Hammerton Inc.
217 Wright Brothers Drive
Salt Lake City, UT 84116

801-973-8095 EXT: 4
www.hammerton.com

Warranty

Please visit:
<https://studio.hammerton.com/lifetime-limited-warranty/>
to view the Hammerton Studio Warranty Policy

HAMMERTONSTUDIO™

Assembly Instructions

Nightfall/Twilight Outdoor Sconce

Image below is a representation of applicable product collection

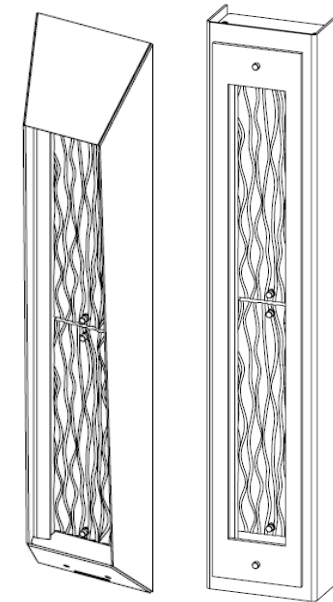

ODB0101/ODB0102

**WARNING: FAILURE TO INSTALL THIS
FIXTURE PROPERLY MAY RESULT IN
SERIOUS PERSONAL INJURY OR DEATH
AND PROPERTY DAMAGE.**

It is recommended that this product be installed
by a licensed electrician.

41-001-00323
Rev 1

Included Components

- A. Hardware Packet T, with Instructions
- B. Sconce Light Body
- C. #8-32 x 1" Phillips Head screws (Qty:2)
- D. Universal Plate for Wall Mounting

Required Tools

- 1. Phillips screw driver (not provided)
- 2. Wire cutters/strippers (not provided)
- 3. Measuring tape (not provided)
- 4. Sealing compound for weatherproofing (not provided, outdoor only)

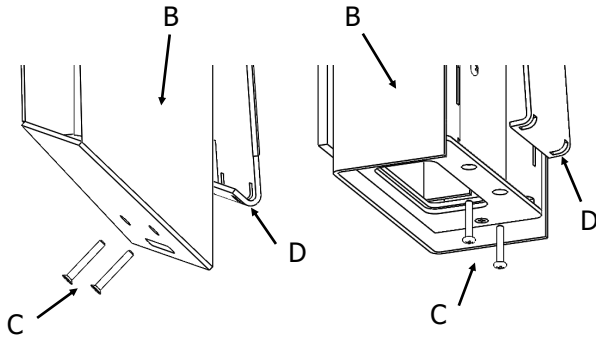

Example Fixture Shown: ODB0101-48 (left) ODB0102-48

Fixture Preparation

Step 1: Gently remove Universal Plate (D) by loosening or removing 8-32 screws (C) from bottom of fixture. Swing Universal Plate out from back of fixture.

Assembly Instructions

Step 1: Mount the Sconce Light Body, following the instructions included in the hardware packet. The Universal Plate has multiple locations for mounting so that the height of the fixture can be varied. The mounting holes and wire passthrough must line up with the J-Box to prevent the wires from being pinched. Use the additional 4 screws to secure the top and bottom of the Universal securely to the wall.

Step 2: Measure distance from J-Box and trim the ground wire and hot and neutral wires to the correct distance to reach the J-Box. Connect ground to ground, neutral to white, and hot to black wires using supplied wire nuts in hardware pack.

Step 3: If installing in an outdoor location, **FULLY SEAL** the perimeter of the sconce to the wall with silicone sealant to prevent water from entering the J-Box.

Step 4: Place the fixture on the universal by catching the top slot on the cleat of the Universal. Then swing the fixture down into place, making sure to clear the lower retaining portion of the Universal. Once fixture is aligned properly with the Universal, tighten the 8-32 screws (C) (that were loosened in preparation) into

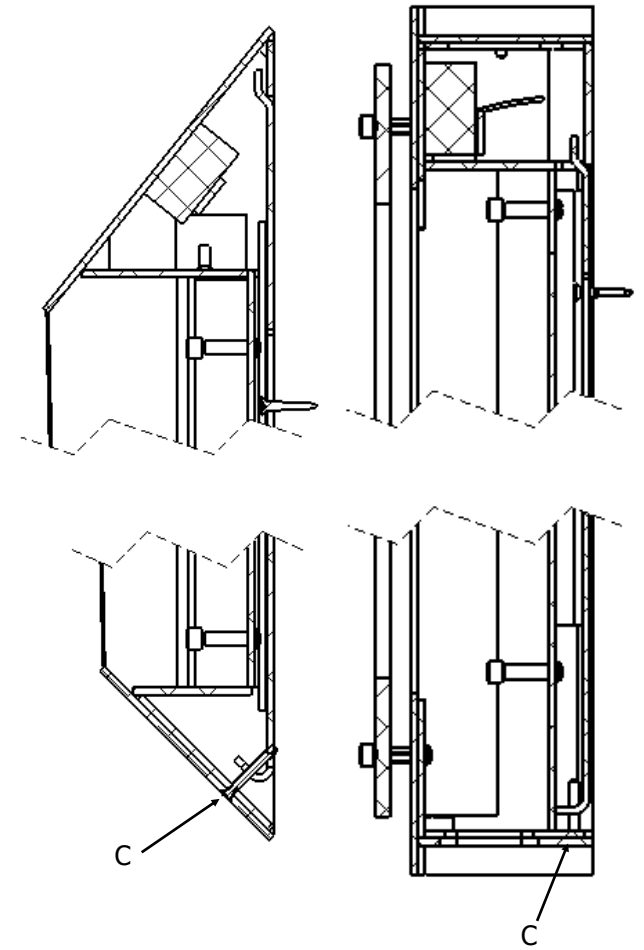
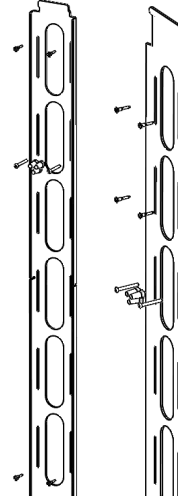

Note: Make sure screws (C) are fully seated to secure fixture to wall.

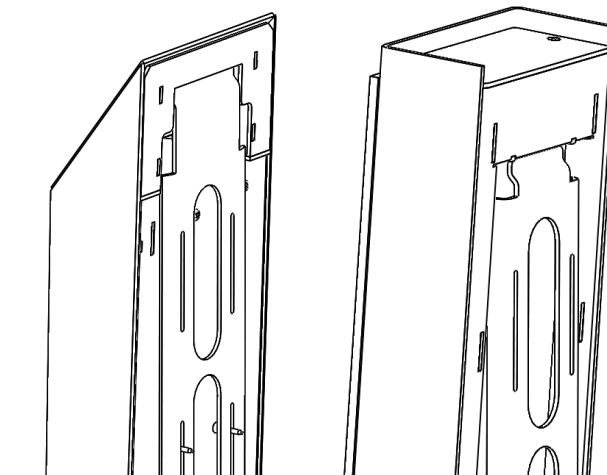

the retaining slots on the Universal.