

POP S400 ON-OFF 110V

ver. 20200404_Rev_0

year: 2018
code: 2540301A00600
type: hanging lamp
application: indoor

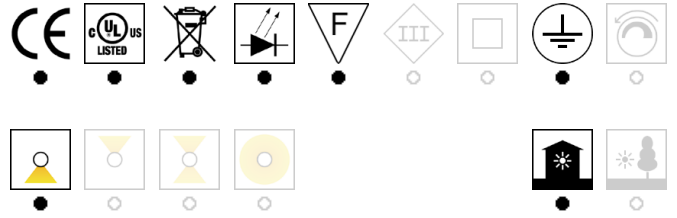

Technical drawing
Size ref. image mm - inch

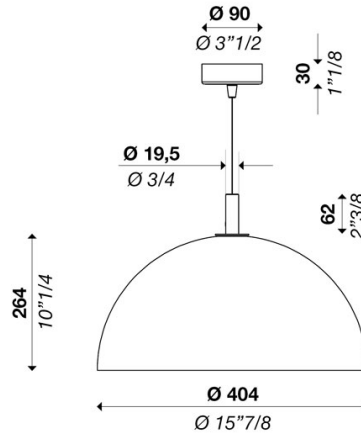

Technical data

Light source	LED bulb
Circuit structure	LED bulb
Light emission direction	direct
Power	1x MAX 20W E26
Source lumens	-
Source efficacy	-
Consumption	-
Delivered lumens	-
Luminaire efficacy	-
Secondary	-
Colour temperature	-
Colour rendering index	-
Standard Deviation of Colour Matching	-
Energy class	A
Safety class	I
Degree of protection	IP 20
Direct mounting on normally flammable surfaces	●
Operating temperature	+10° / +40°
CE	●
UL	●
Optional	
Emergency mode	○
Motion sensor	○
Directional	○

Packing

Net weight	
Packaging 1	
Packaging 2	
Packaging 3	
Packaging 4	
Packaging 5	

Structure

Material	aluminium
Finish	white / variants page 2

Diffuser

Material	
Finish	

Canopy

Size	90 mm - 3" 1/2 inch
Height	30 mm - 1" 1/8 inch
Ceiling mount	direct / variants page 2

Electronics / Driver

Included	No
Quantity	
Voltage	100-120V 60 Hz

Dimmable



Hanging cables

Stainless steel cables standard length (custom available)	○
Electric cable standard length (custom available)	2500 mm/100"

Warranty

Duration	2 years
----------	---------

POP S400 ON-OFF 110V

ver. 20200404_Rev_0

year: **2018**
code: **2540301A00600**
type: **hanging lamp**
application: **indoor**

Available variants

Colour temperature

bulb



custom



Structure finish

gold / brass



matt white



matt black



embossed white



embossed black



Ceiling Mount

direct



custom

