

# ASSEMBLY & INSTALLATION INSTRUCTIONS

Trilogy Pendant 181603

A1048

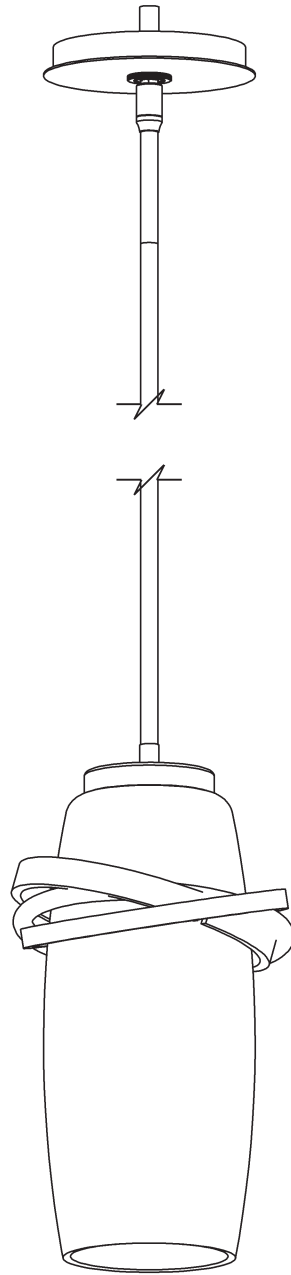

HUBBARDTON FORGE.

MODERN AMERICAN BLACKSMITHS | FINE, HAND CRAFTED LIGHTING  
CASTLETON, VERMONT USA | HUBBARDTONFORGE.COM

**Component Parts**

- A Fixture**
- B Crossbar**
- C Jam Nut**
- D Canopy Coupling**
- E Threaded Nipple**
- F Ground Screw**
- G Canopy Ring**
- H Canopy**
- I 3" Fixture Pipe (1)**
- J 6" Fixture Pipe (1)**
- K 12" Fixture Pipe (3)**
- L Stem Nipples (7)**
- M Swivel**
- N Socket**
- O Bulb (not included)**
- P Glass**
- Q Ring Assembly**
- R Washer**
- S Retaining Ring**



# ASSEMBLY & INSTALLATION INSTRUCTIONS

A1048

Trilogy Pendant 181603

**CAUTION: FAILURE TO INSTALL THIS FIXTURE PROPERLY MAY RESULT IN SERIOUS PERSONAL INJURY OR DEATH AND PROPERTY DAMAGE.** We recommend installation by a licensed electrician. This product must be installed in accordance with applicable installation code(s), by a person familiar with the construction and operation of the product and the hazards involved.\*

Caution: Do not exceed maximum wattage noted on fixture. Use only recommended bulbs with fixture.

Please Note: After installation extra hardware and accessories are possible due to our kits are used on multiple products and options.

## To Install Fixture (Figure 1) on following page

**CAUTION: BE SURE POWER IS OFF AT THE MAIN BREAKER BOX PRIOR TO INSTALLATION.**

1. Carefully unpack fixture (A) from the carton.
2. Jam nut (C), canopy coupling (D), threaded nipple (E), canopy ring (G), one stem nipple (L), and swivel (M) are already assembled. Thread the assembly into crossbar (B) with ground screw (F) facing towards canopy coupling (D); leave both parts loose.
3. Using two machine screws (not provided), temporarily fasten crossbar (B) to the electric box.

**NOTE: A NEW ELECTRIC BOX COMES WITH SCREWS. WHEN REPLACING A FIXTURE, RETAIN THE EXISTING SCREWS FOR USE WITH THE NEW FIXTURE.**

4. Remove canopy ring (G) from canopy coupling (D) and slide canopy (H) into the assembly, thread canopy ring (G) back onto canopy coupling (D), then adjust the length of threaded nipple (E) in crossbar (B) so that canopy ring (G) can hold canopy (H) against the ceiling with no threads showing for best appearance. When the correct adjustment is established, tighten jam nut (C) against crossbar (B) to secure the adjustment.
5. Remove crossbar (B) from the electrical box and canopy ring (G) from canopy coupling (D) and proceed with the assembly instructions.
6. Locate fixture pipes (I, J, K), fixture (A), stem nipples (L) . Stem nipples (L) can be found in the kit bag.
7. Provided are multiple fixture pipes in three different lengths. Choose the combination that will achieve the overall height desired. Refer to the table below to determine the pipes required to reach the desired overall height. Once you have determined the components necessary, feed the wires that exit fixture (A) through the individual components. Wires will slip easier through loose components than through pipes and nipples that are pre-assembled. Once wires are run, apply thread locking compound to all the connection points and assemble the pipes and couplings.

		Overall Height of Fixture														
		18.7	21.7	24.7	27.7	30.7	33.7	36.7	39.7	42.7	45.7	48.7	51.7	54.7	57.7	60.7
# of Pipes Required	3" Pipe	1		1		1		1		1		1		1		1
	6" Pipe		1	1			1	1			1	1			1	1
	12" Pipe				1	1	1	1	2	2	2	2	3	3	3	3

**NOTE: APPLICATION OF THE THREAD LOCKING COMPOUND IS NECESSARY TO PREVENT THE PIPE FROM LOOSENING DURING REGULAR MAINTENANCE AND CLEANING OF THE FIXTURE. BE CERTAIN TO APPLY THE COMPOUND.**

8. Carefully slide canopy ring (G) and canopy (H) over wires and fixture pipes (I, J, K) until they rest on fixture (A).

# ASSEMBLY & INSTALLATION INSTRUCTIONS

A1048

## Trilogy Pendant 181603

- Slip wires from fixture (A) through the crossbar assembly and thread onto fixture pipe.
- Using two machine screws (not provided), fasten crossbar (B) to the electric box. (Figure 1)
- Using suitable wire connectors (not provided) connect fixture wires to supply (white/ribbed to white and black/smooth to black). Attach a pigtail lead to crossbar ground screw (F). Hold canopy (H) close, connect all ground wires (bare copper or green to bare copper or green).

**CAUTION: MAKE SURE WIRE CONNECTORS ARE TWISTED ON SECURELY, AND NO BARE WIRE IS EXPOSED.**

- Slide canopy (H) against ceiling, and secure with canopy ring (G).

**CAUTION: BE SURE NO WIRES ARE PINCHED BETWEEN CANOPY (H) AND THE CEILING.**

- Refer to instructions on next page to install glass.

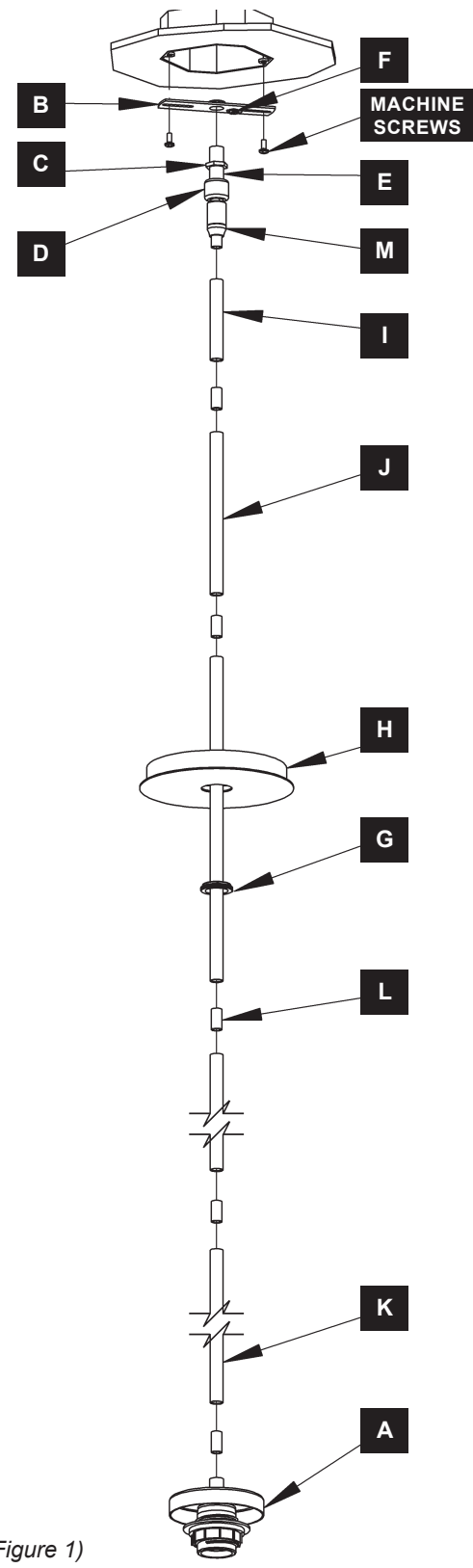

(Figure 1)

## Trilogy Pendant 181603

### To Install Glass (Figure 2)

1. Carefully unpack glass (P) and ring assembly (Q).
  2. Retaining ring (S) ships on socket (N). Remove and retain for next steps.
  3. Place ring assembly (Q) onto glass (P) as shown in Figure 2.
- NOTE:** *Felt pads and rubber bumpers are supplied if needed to hold ring assembly in desired location.*
4. Slide glass (P) over socket (N) and up to cup. Slide washer (R) over socket (N).
  5. Thread retaining ring (S) onto socket (N) and tighten to secure glass (P).
- CAUTION:** *Be careful not to overtighten as this could break glass.*
6. Install bulb (O), not included, into socket (N).
  7. Restore electricity at main breaker.

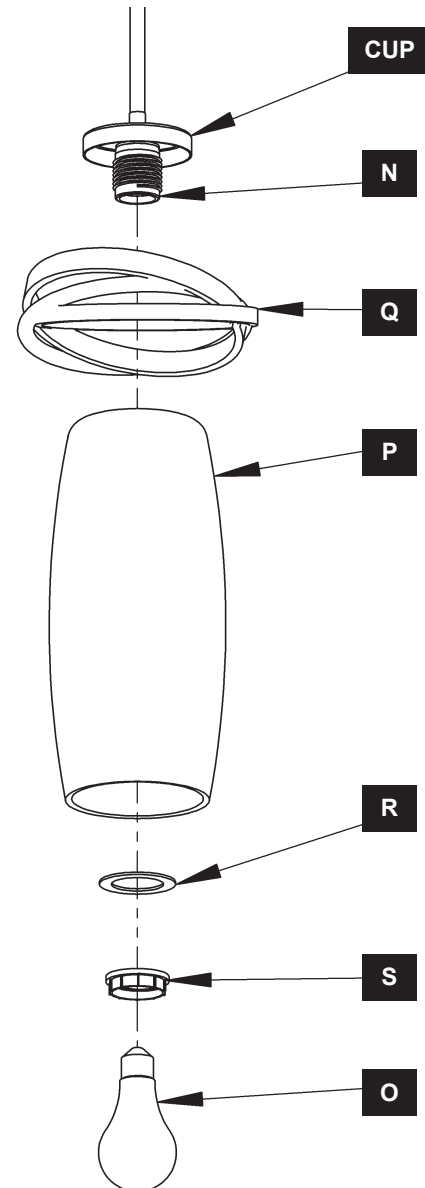

(Figure 2)

If you need further assistance, or find that you are missing any parts, please contact the dealer from which you purchased this product.  
We hope you enjoy your fixture!

**\* Hubbardton Forge will not be liable for injury or damage caused by improper installation, lamping or use of this fixture.**