

ASSEMBLY & INSTALLATION INSTRUCTIONS

Sprig 6lt Semi Flush 128716

A1004

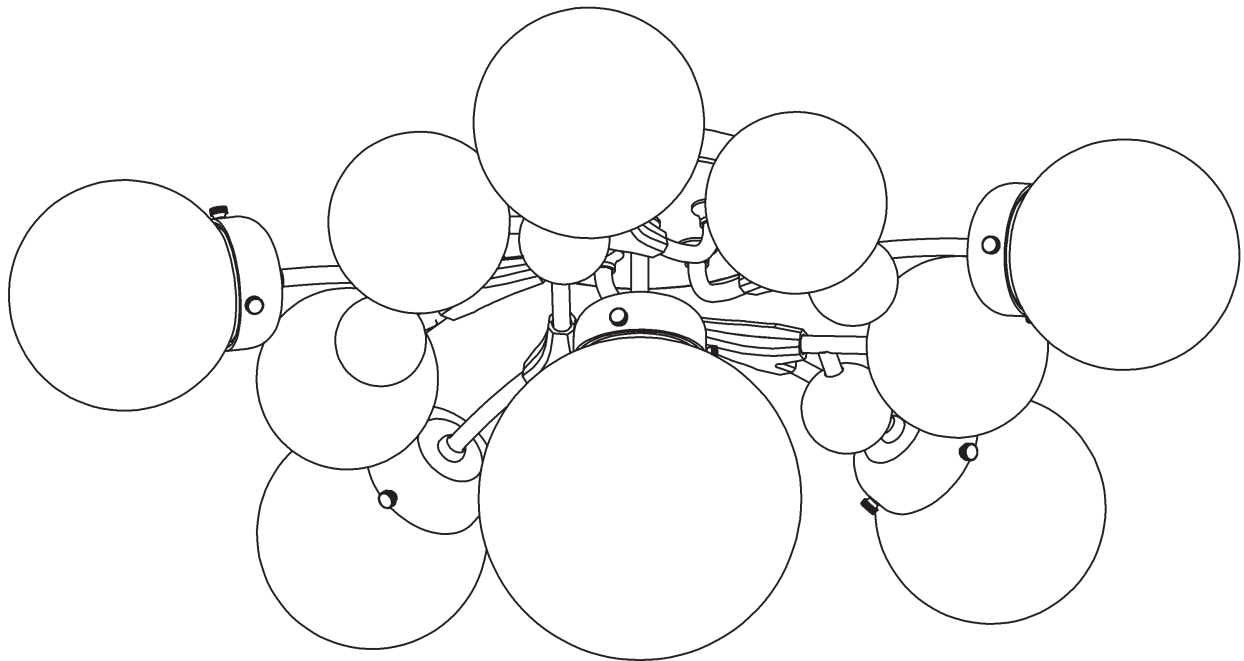

Component Parts

A	Fixture
B	Mounting Bracket
C	Ground Screw
D	Cupped Washer
E	#8 Screws (3)
F	Socket (6)
G	Cup (6)
H	Bulb (not included)
I	Glass Sm (5)
J	Glass Lg
K	Thumb Screws (18)



ASSEMBLY & INSTALLATION INSTRUCTIONS

A1004

Sprig 6lt Semi Flush 128716

CAUTION: FAILURE TO INSTALL THIS FIXTURE PROPERLY MAY RESULT IN SERIOUS PERSONAL INJURY OR DEATH AND PROPERTY DAMAGE. We recommend installation by a licensed electrician. This product must be installed in accordance with applicable installation code(s), by a person familiar with the construction and operation of the product and the hazards involved.*

Caution: Do not exceed maximum wattage noted on fixture. Use only recommended bulbs with fixture.

Please Note: After installation extra hardware and accessories are possible; our kits are used on multiple products.

To Install Fixture (Figure 1)

CAUTION: BE SURE POWER IS OFF AT THE MAIN BREAKER BOX PRIOR TO INSTALLATION.

1. Carefully unpack the fixture (A) from the carton.
2. Mounting bracket (B) is shipped installed in fixture (A). Remove #8 screws (E) to separate. Retain screws for later use.
3. Using two machine screws (not provided) attach crossbar (B) to the electric box using oval holes to orient fixture.

Note: A new electric box comes with screws. When replacing a fixture, retain the existing screws for use with the new fixture.

4. Attach a pigtail lead to bracket (B) using ground screw (C) and cupped washer (D) found in kit bag.
5. Hold fixture (A) close to ceiling. Using suitable wire connectors (not provided) connect fixture wires to supply (white to white and black to black). Connect all ground wires (bare copper or green to bare copper or green).

CAUTION: MAKE SURE WIRE CONNECTORS ARE TWISTED ON SECURELY, AND NO BARE WIRE IS EXPOSED.

6. Carefully tuck all wires inside fixture (A), push fixture firmly against the ceiling.
7. Align holes in fixture (A) with holes in bracket (B) and secure with (3) #8 screws (E). For ease of install, start all screws before tightening completely.

Note: Be sure no wires are pinched between the ceiling and the fixture.

8. See instructions on next page to complete installation.

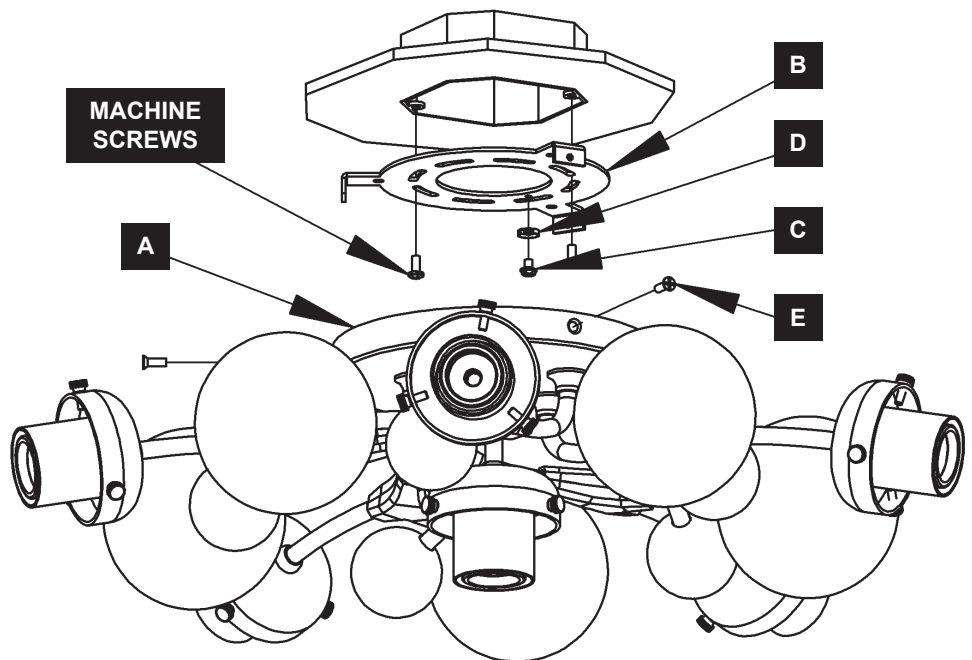

(Figure 1)

ASSEMBLY & INSTALLATION INSTRUCTIONS

A1004

Sprig 6lt Semi Flush 128716

To Install Glass (Figure 2)

1. Unpack glass (I & J).
2. Install bulbs (H) (not included) into sockets (F).
3. Place glass (J) over the bulb (H).
4. Slide glass (J) into cup (G) until groove in glass lines up with thumb screws (K).

Note: Thumb screws are shipped in cups. It may be necessary to loosen thumb screws so glass can pass into cup. Screws will not need to be removed completely.

5. Tighten thumb screws (K) evenly to secure glass (J).

Note: Do not overtighten screws as this could break glass.

6. Repeat steps for remaining small glass (I).

Figure 2 shows recommended glass locations.

7. Restore electricity at main breaker.

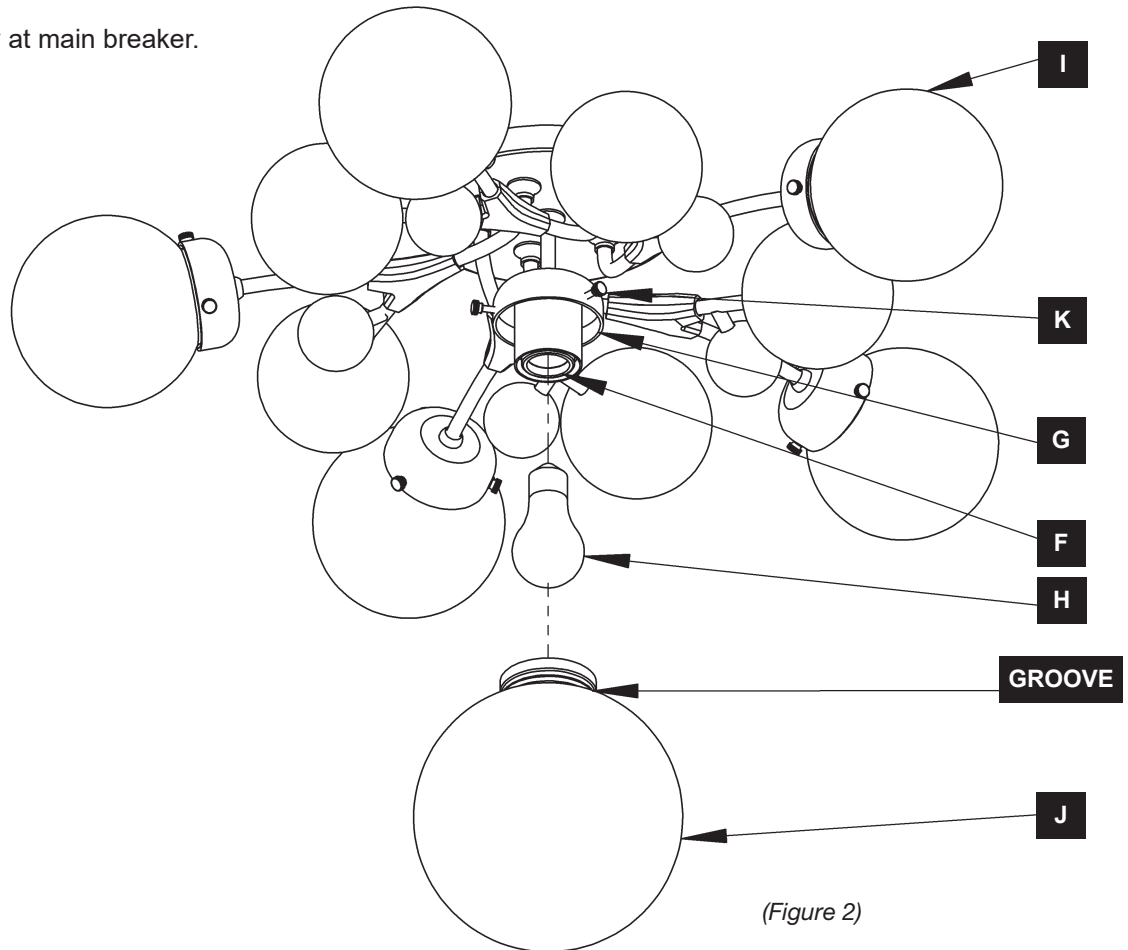

(Figure 2)

If you need further assistance, or find that you are missing any parts, please contact the dealer from which you purchased this product. We hope you enjoy your fixture!

* Hubbardton Forge will not be liable for injury or damage caused by improper installation, lamping or use of this fixture.