

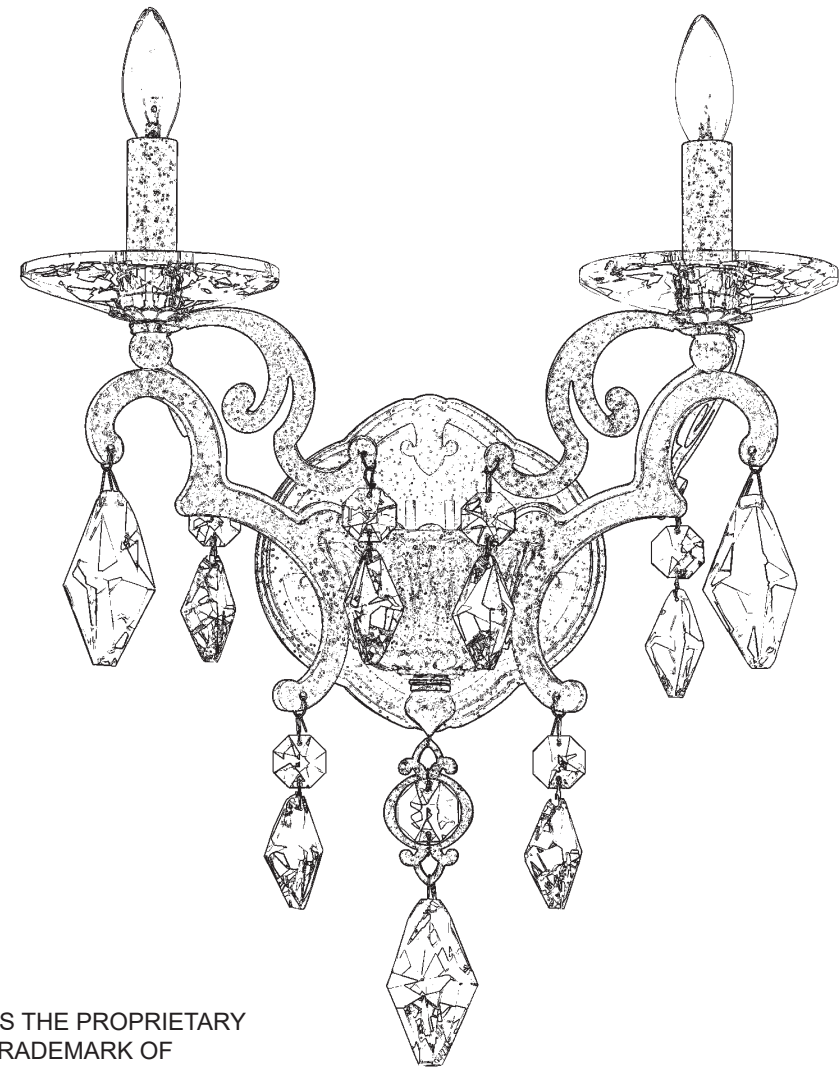









TAMERLAINE  
S92602- \_\_ \_\_ R



THIS DESIGN IS THE PROPRIETARY  
TRADE DRESS/TRADEMARK OF  
W SCHONBEK LLC.

SCHONBEK  
*Signature*<sup>TM</sup>

SCHONBEK  
*Signature*<sup>TM</sup>

								
MAX 60 W		110-120 V						

**WARNING:**

1

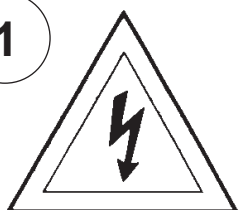

**Electrical Danger**

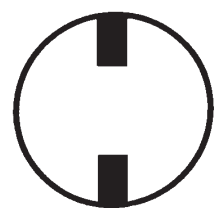

**Turn Power Off**

All electrical components must be installed by a licensed electrician in accordance with the National Electric Code and the appropriate local electrical codes.

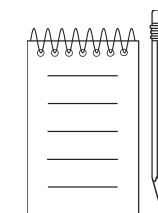
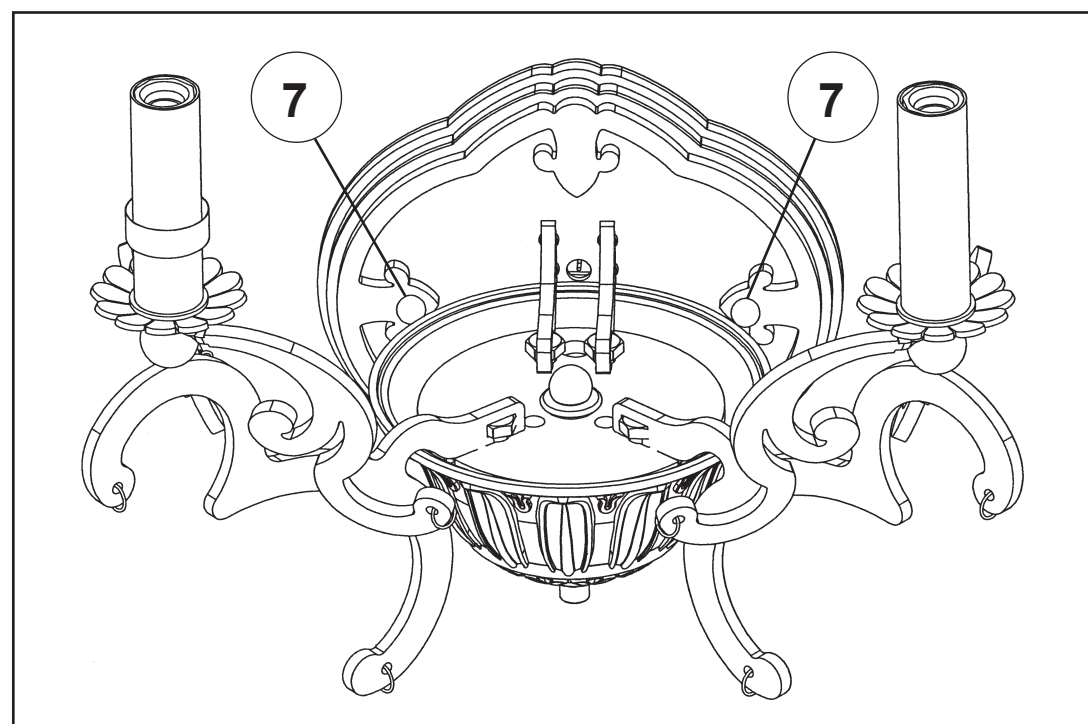
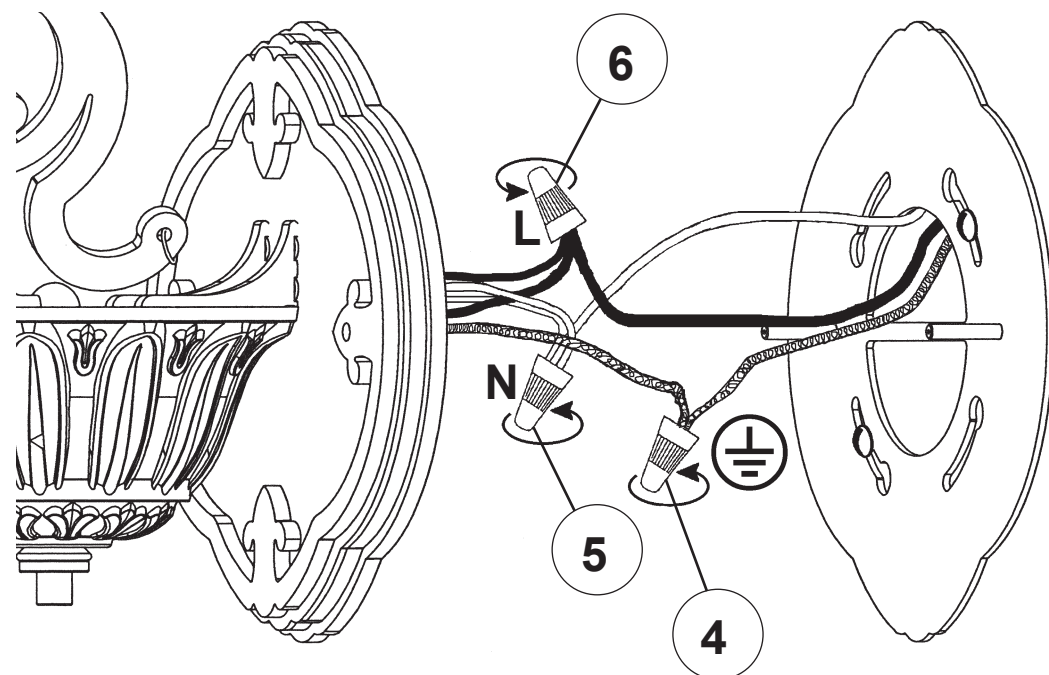
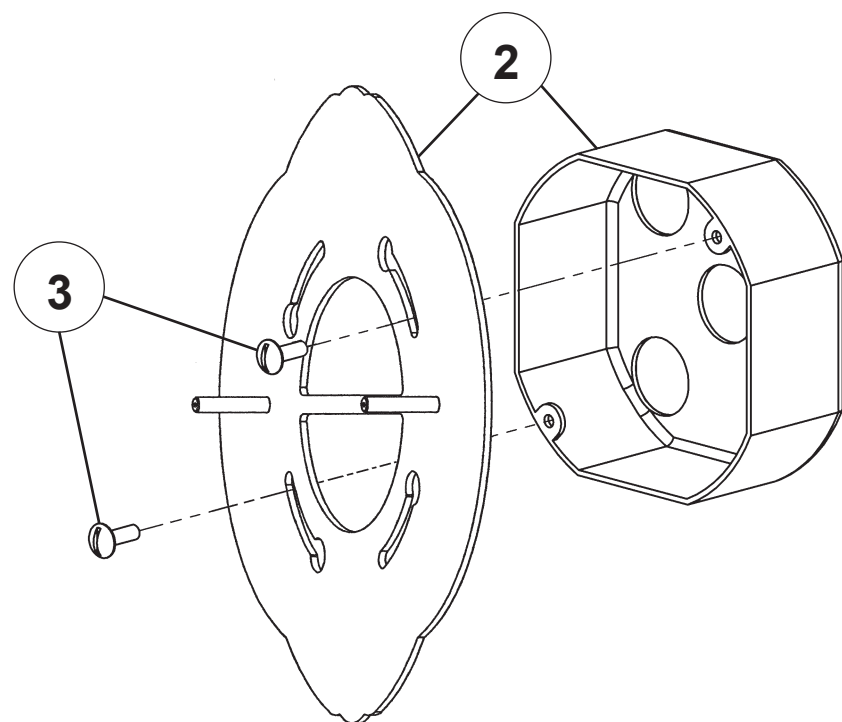

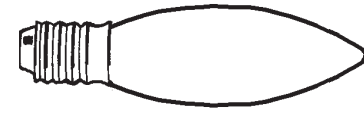
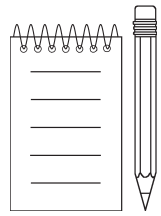

You will need 2 - B10  
25 Watts Recommended  
60 Watts Max

**Install bulbs and be sure  
to test fixture BEFORE  
trimming.**

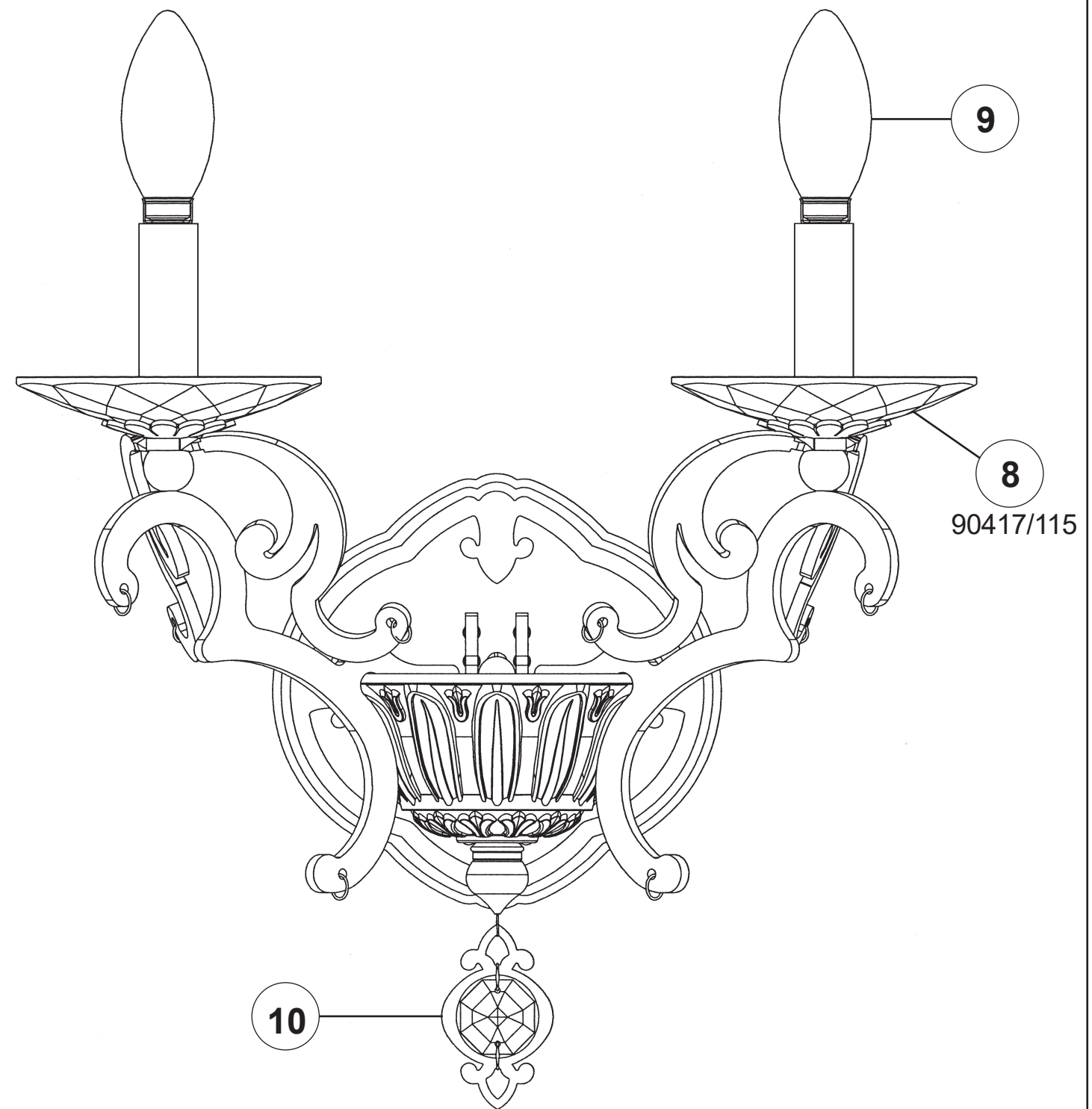

90417/115

**NR24349-\*\***

