



ELEVATE

Reference Drawings & Instructions

Item #895840-XX2

32" Round Canopy Configuration 2
(For Low Ceilings) All Glass Options

For specific glass option, refer to style number listed on
the bottom of instruction pages.

CUSTOMER REFERENCE DRAWING - CONFIGURATION - FOR LOW CEILINGS

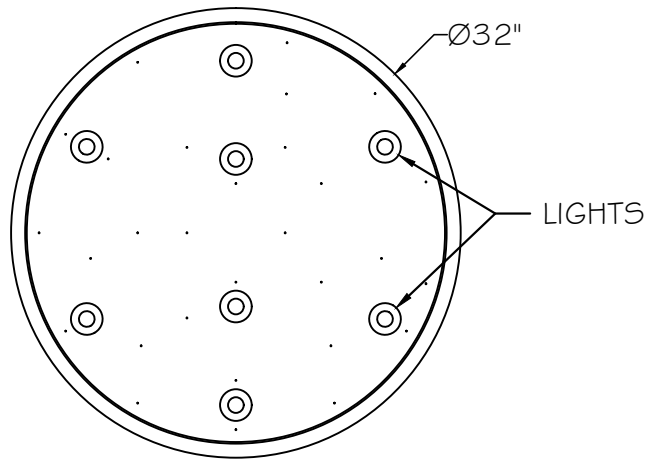



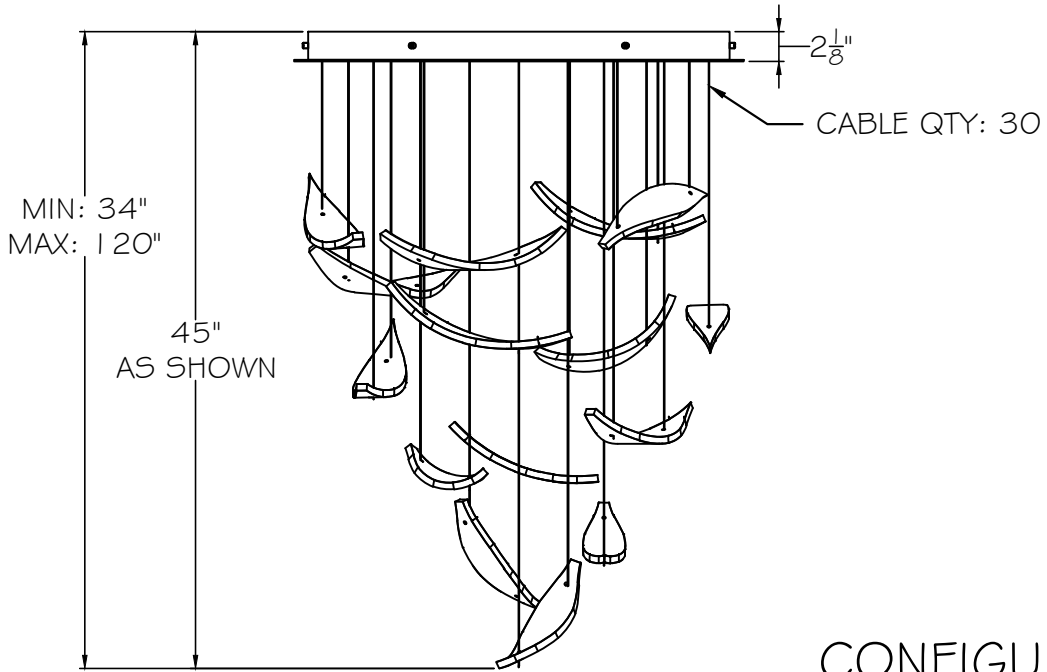



TOP VIEW



FRONT VIEW

CONFIGURATION 2
SHEET 2 OF 2

THUMBNAIL IMAGES OF STYLE OPTIONS:

<p>-112 SILVER -212 GOLD</p>  <p>GLASS PLUME W/ DICHRO (X15)</p>	<p>-122 SILVER -222 GOLD</p>  <p>GLASS PLUME NO DICHRO (X15)</p>	<p>-132 SILVER -232 GOLD</p>  <p>GLASS SPIRE CLEAR (X17)</p>	<p>-142 SILVER -242 GOLD</p>  <p>GLASS SPIRE BLACK (X17)</p>	<p>-152 SILVER -252 GOLD</p>  <p>GLASS SPIRE METEORITE (X17)</p>
<p>-161 SILVER -261 GOLD</p>  <p>FROZEN PAGES (FRIT) (X15)</p>	<p>-171 SILVER -271 GOLD</p>  <p>BLANK PAGES (WHITE) (X15)</p>			



This drawing, specifications and the product depicted are the exclusive property of Fine Art Handcrafted Lighting®. In compliance with US copyright and patent requirements, notice is hereby given that this document and the product depicted shall not be copied, altered or used in any manner without the expressed written consent of Fine Art Handcrafted Lighting®.

www.finearthl.com

Tel:(305) 821-3850
FINE ART LAMPS®

Fax:(305) 513-5736

STYLE NUMBER:

895840

DATE:

10/13/2020

INSTRUCTIONS for PLUMES (Dichro & White)

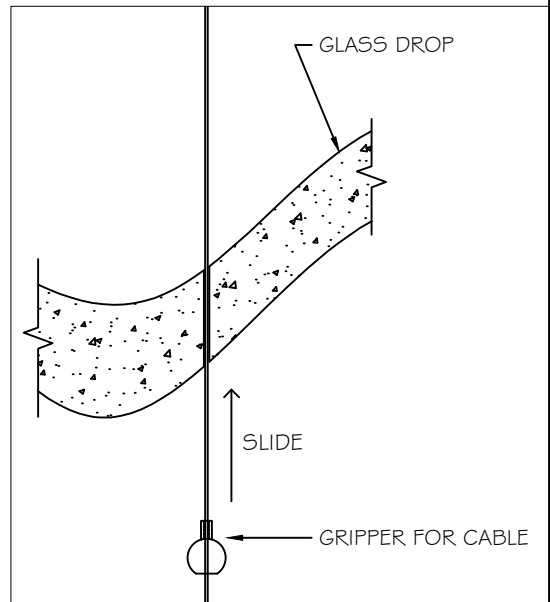
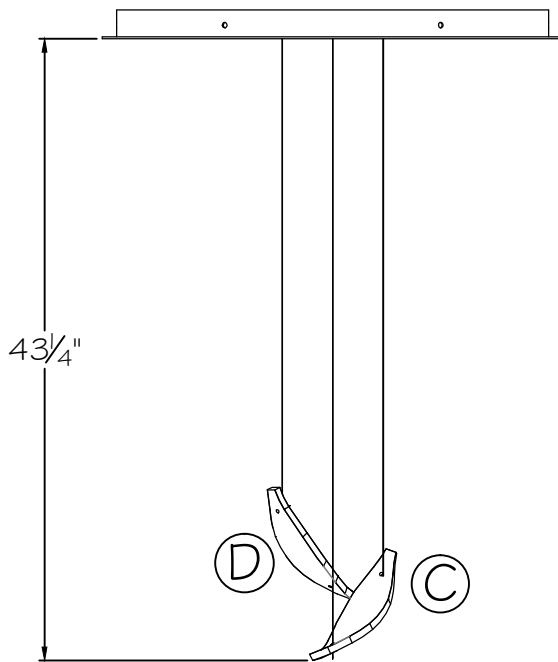
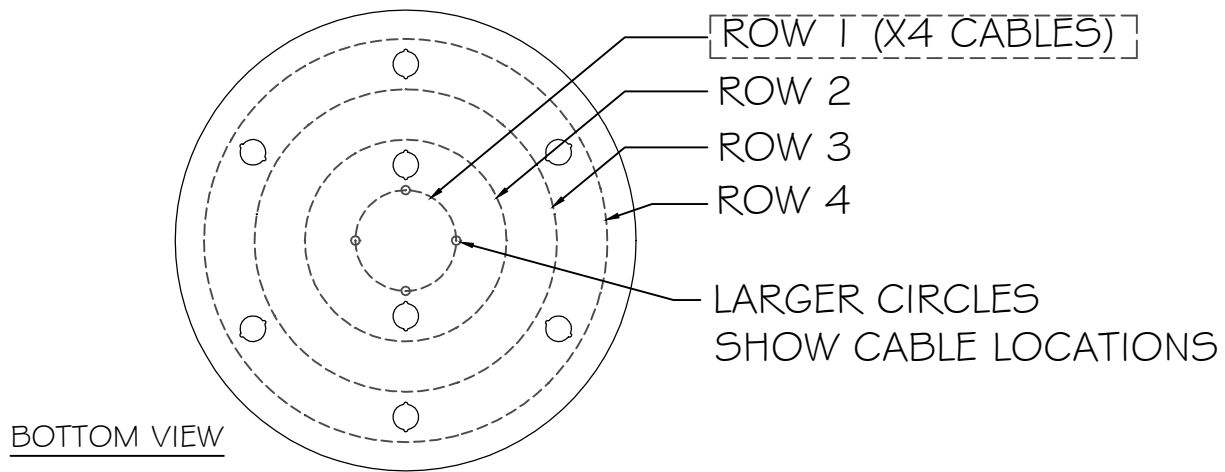

ROW 1

GLASS TYPE	QUANTITY
TYPE A	0
TYPE B	0
TYPE C	1
TYPE D	1

- ROW 1 OF GLASSES TO BE INSTALLED FIRST.
- GATHER ALL OTHER CABLES TO EASILY ACCESS LAYER TO BE WORKED ON
- LETTERS IN CIRCLES ON DIAGRAM INDICATE GLASS TYPE THAT CORRESPONDS TO STICKERS ON GLASS
- START SLIDING GLASSES UP INTO POSITION AS SHOWN ON FRONT VIEW, STARTING FROM TOP TO BOTTOM
- SLIDE GRIPPER UP TO HOLD POSITION OF GLASS
- NOTE: MULTIPLE GLASSES MAY USE THE SAME CABLES

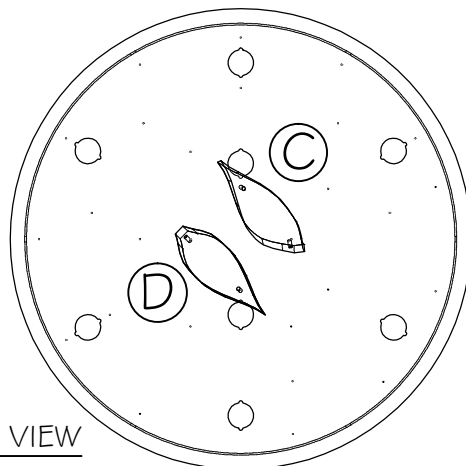

STYLE(S) #: 895840-112 -212 -122 -222



This drawing, specifications and the product depicted are the exclusive property of Fine Art Handcrafted Lighting®. In compliance with US copyright and patent requirements, notice is hereby given that this document and the product depicted shall not be copied, altered or used in any manner without the expressed written consent of Fine Art Handcrafted Lighting®.

www.finearthl.com

Tel:(305) 821-3850
 FINE ART LAMPS®

Fax:(305) 513-5736

INSTRUCTION #:

00791415

SHEET

1 / 5

INSTRUCTIONS for PLUMES (Dichro & White)

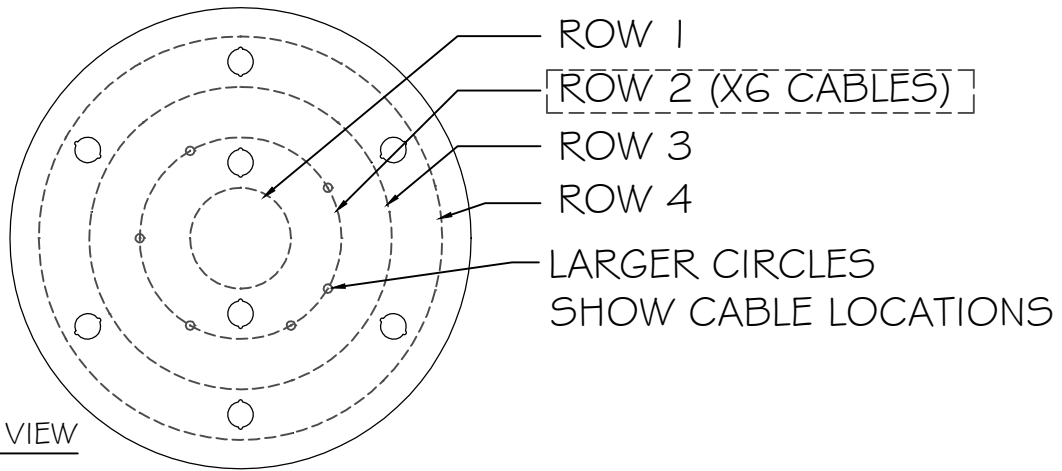

BOTTOM VIEW

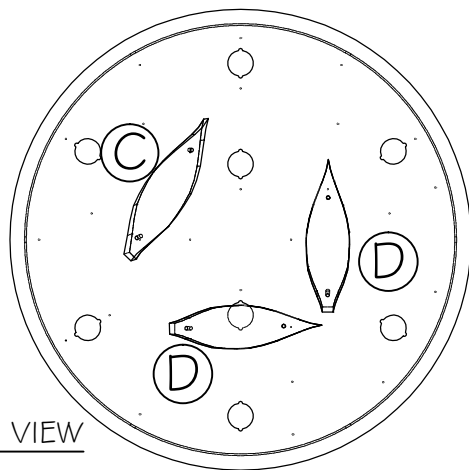
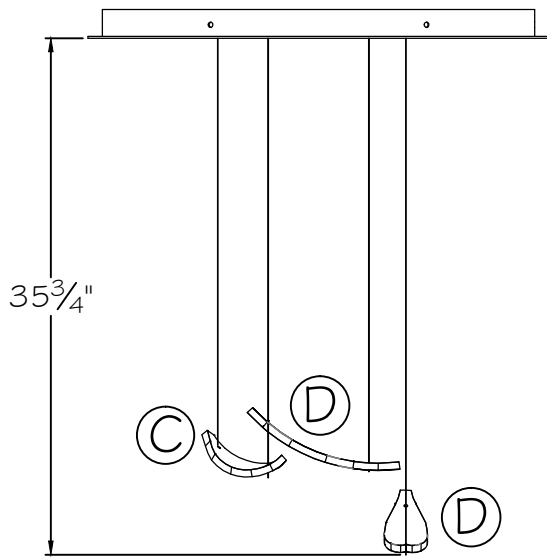

BOTTOM VIEW

ROW 2	
GLASS TYPE	QUANTITY
TYPE A	0
TYPE B	0
TYPE C	1
TYPE D	2

- ROW 2 OF GLASSES TO BE INSTALLED NEXT.
- START SLIDING GLASSES UP INTO POSITION AS SHOWN ON FRONT VIEW, STARTING FROM TOP TO BOTTOM
- SLIDE GRIPPER UP TO HOLD POSITION OF GLASS
- NOTE: MULTIPLE GLASSES MAY USE THE SAME CABLES

STYLE(S) #: 895840-112 -212 -122 -222



This drawing, specifications and the product depicted are the exclusive property of Fine Art Handcrafted Lighting®. In compliance with US copyright and patent requirements, notice is hereby given that this document and the product depicted shall not be copied, altered or used in any manner without the expressed written consent of Fine Art Handcrafted Lighting®.

www.finearthl.com

Tel:(305) 821-3850
FINE ART LAMPS®

Fax:(305) 513-5736

INSTRUCTION #:

00791415

SHEET

2 / 5

INSTRUCTIONS for PLUMES (Dichro & White)

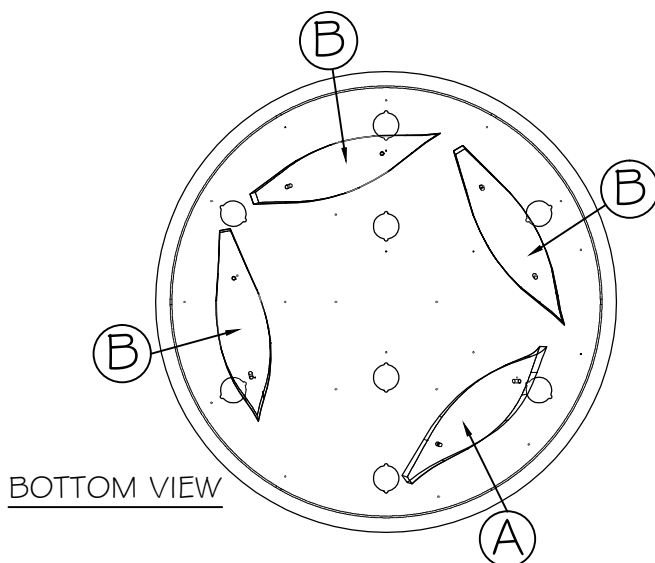
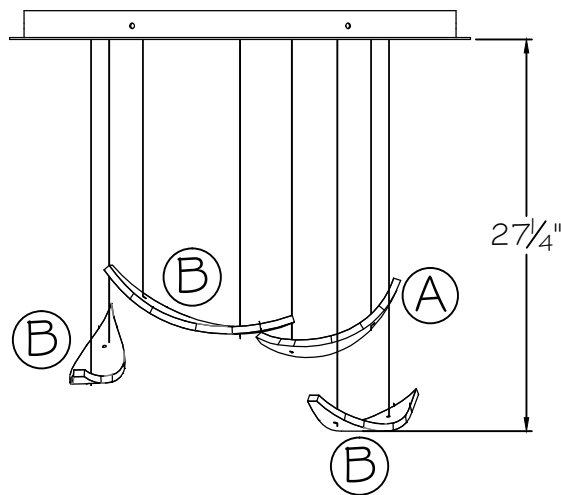
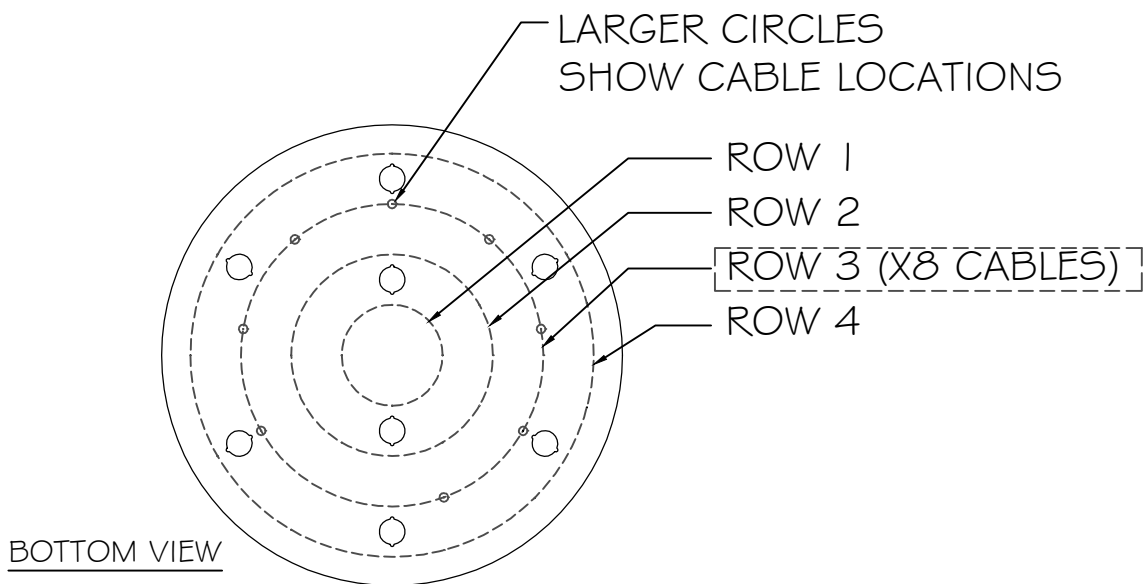

ROW 3	
GLASS TYPE	QUANTITY
TYPE A	1
TYPE B	3
TYPE C	0
TYPE D	0

- ROW 3 OF GLASSES TO BE INSTALLED NEXT.
- START SLIDING GLASSES UP INTO POSITION AS SHOWN ON FRONT VIEW, STARTING FROM TOP TO BOTTOM
- SLIDE GRIPPER UP TO HOLD POSITION OF GLASS
- NOTE: MULTIPLE GLASSES MAY USE THE SAME CABLES

STYLE(S) #: 895840-112 -212 -122 -222



This drawing, specifications and the product depicted are the exclusive property of Fine Art Handcrafted Lighting®. In compliance with US copyright and patent requirements, notice is hereby given that this document and the product depicted shall not be copied, altered or used in any manner without the expressed written consent of Fine Art Handcrafted Lighting®.

www.finearthl.com

Tel:(305) 821-3850
FINE ART LAMPS®

Fax:(305) 513-5736

INSTRUCTION #:

00791415

SHEET

3 / 5

INSTRUCTIONS for PLUMES (Dichro & White)

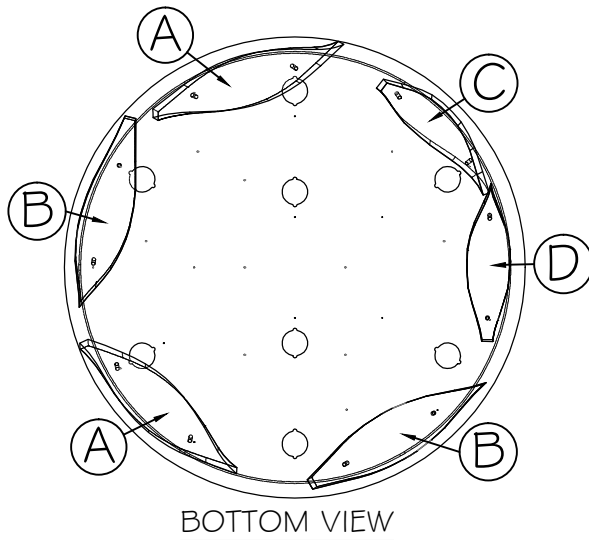
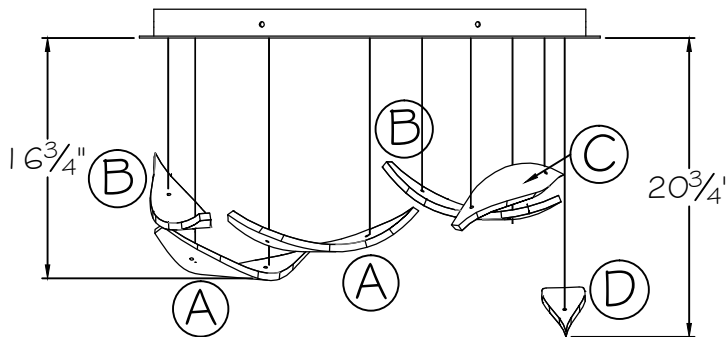
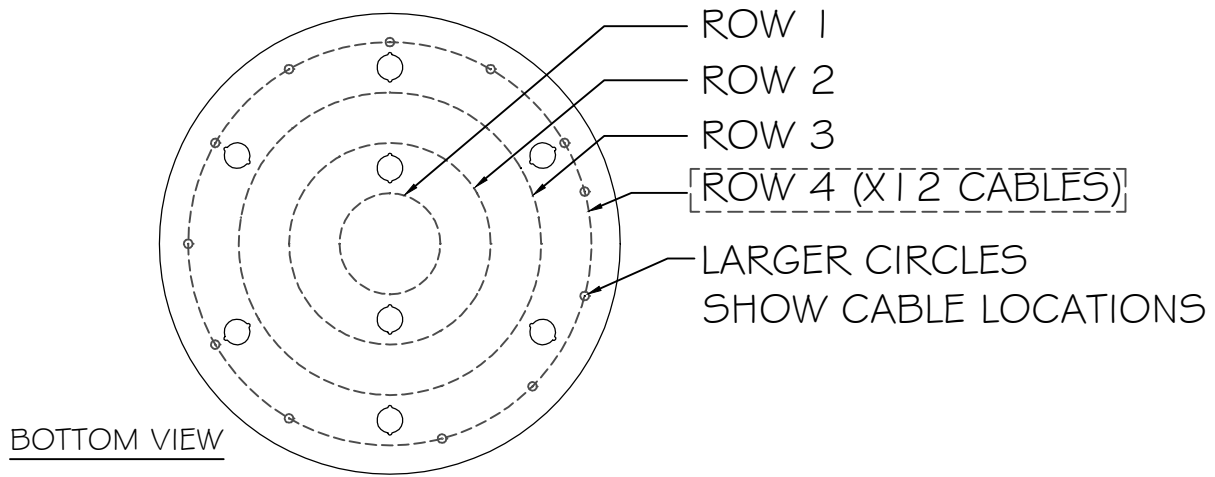

ROW 4	
GLASS TYPE	QUANTITY
TYPE A	2
TYPE B	2
TYPE C	1
TYPE D	1

- ROW 4 OF GLASSES TO BE INSTALLED NEXT.
- START SLIDING GLASSES UP INTO POSITION AS SHOWN ON FRONT VIEW, STARTING FROM TOP TO BOTTOM
- SLIDE GRIPPER UP TO HOLD POSITION OF GLASS
- NOTE: MULTIPLE GLASSES MAY USE THE SAME CABLES

STYLE(S) #: 895840-112 -212 -122 -222



This drawing, specifications and the product depicted are the exclusive property of Fine Art Handcrafted Lighting®. In compliance with US copyright and patent requirements, notice is hereby given that this document and the product depicted shall not be copied, altered or used in any manner without the expressed written consent of Fine Art Handcrafted Lighting®.

www.finearthl.com

Tel:(305) 821-3850
FINE ART LAMPING®

Fax:(305) 513-5736

INSTRUCTION #:

00791415

SHEET

4 / 5

INSTRUCTIONS for PLUMES (Dichro & White)

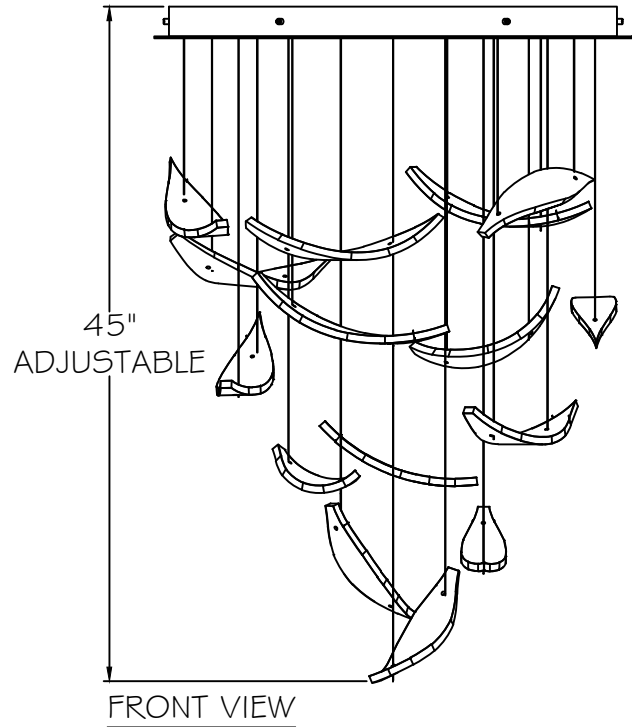
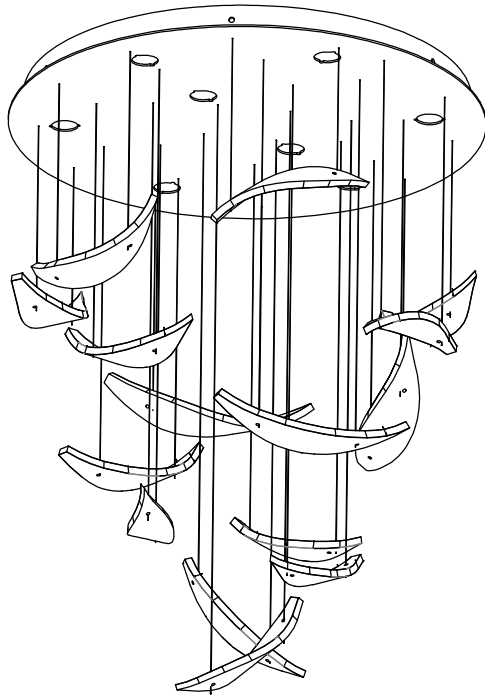

- ONCE ALL GLASSES ARE INSTALLED AND FINAL GLASS POSITION IS ACHIEVED, ENSURE TO CUT EXCESS CABLES UP TO HARDWARE OF LOWEST GLASSES. REFERENCE INSTALLATION INSTRUCTIONS.

STYLE(S) #: 895840-112 -212 -122 -222



This drawing, specifications and the product depicted are the exclusive property of Fine Art Handcrafted Lighting®. In compliance with US copyright and patent requirements, notice is hereby given that this document and the product depicted shall not be copied, altered or used in any manner without the expressed written consent of Fine Art Handcrafted Lighting®.

www.finearthl.com

Tel:(305) 821-3850
FINE ART LAMPS®

Fax:(305) 513-5736

INSTRUCTION #:

00791415

SHEET

5 / 5

INSTRUCTIONS for SPIRES (METEORITE, CRYSTAL STARDUST & EBONY STARDUST)

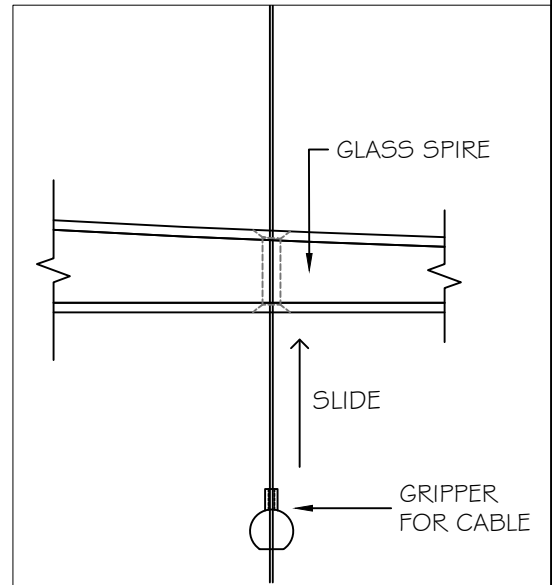
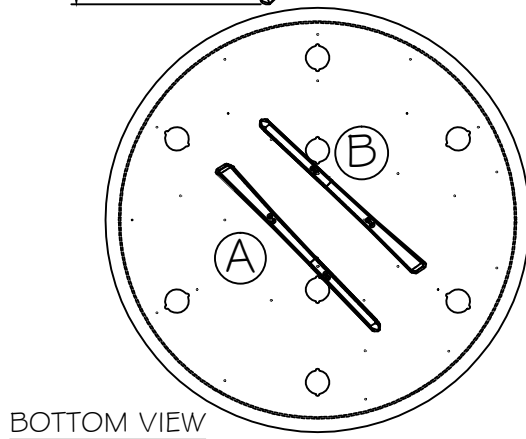
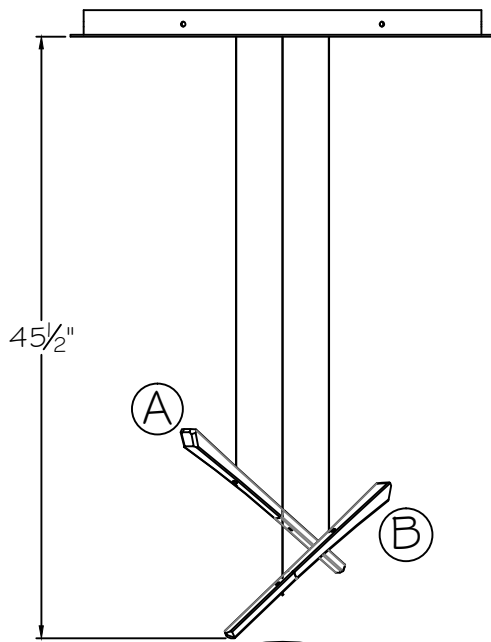
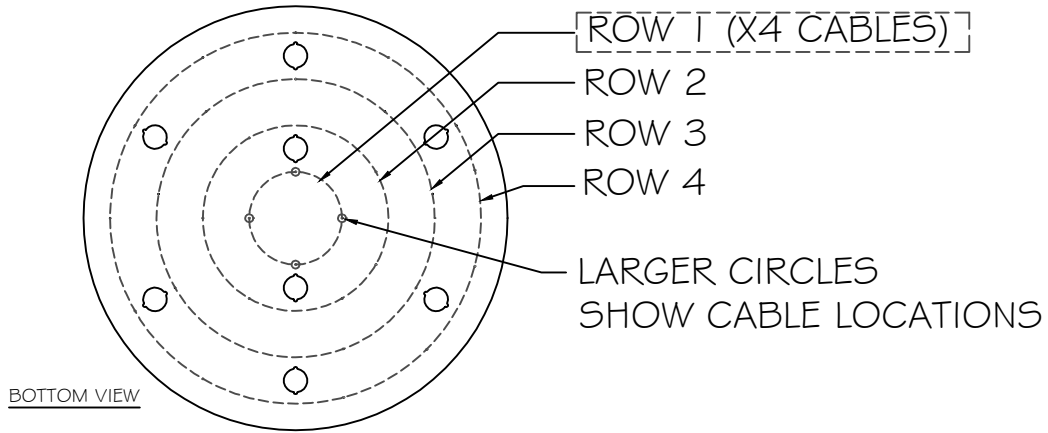

- ROW 1 OF GLASSES TO BE INSTALLED FIRST.
- GATHER ALL OTHER CABLES TO EASILY ACCESS LAYER TO BE WORKED ON
- START SLIDING GLASSES UP INTO POSITION AS SHOWN ON FRONT VIEW, STARTING FROM TOP TO BOTTOM
- SLIDE GRIPPER UP TO HOLD POSITION OF GLASS
- NOTE: MULTIPLE GLASSES MAY USE THE SAME CABLES

STYLE(S) #: 895840-132 -232 -142 -242 -152 -252



This drawing, specifications and the product depicted are the exclusive property of Fine Art Handcrafted Lighting®. In compliance with US copyright and patent requirements, notice is hereby given that this document and the product depicted shall not be copied, altered or used in any manner without the expressed written consent of Fine Art Handcrafted Lighting®.

www.finearthl.com

Tel:(305) 821-3850
FINE ART LAMPS®

Fax:(305) 513-5736

INSTRUCTION #:

00791417

SHEET

1 / 5

INSTRUCTIONS for SPIRES (METEORITE, CRYSTAL STARDUST & EBONY STARDUST)

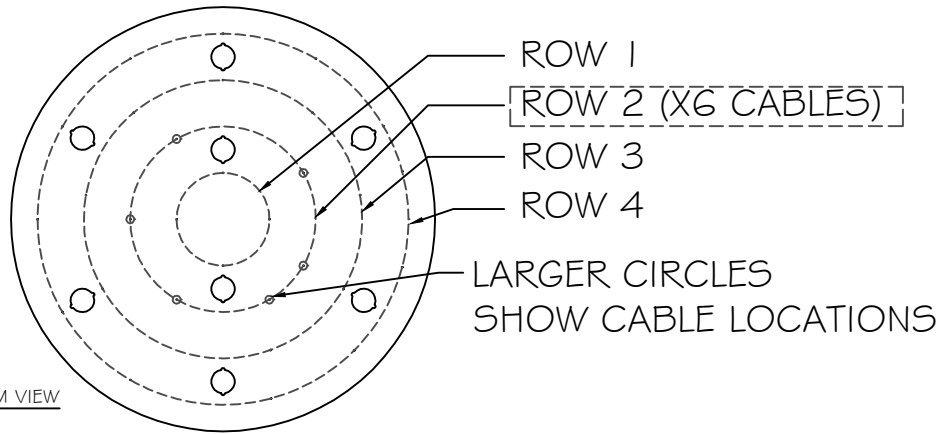

BOTTOM VIEW

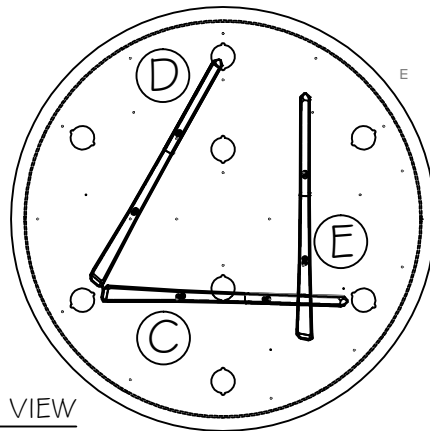
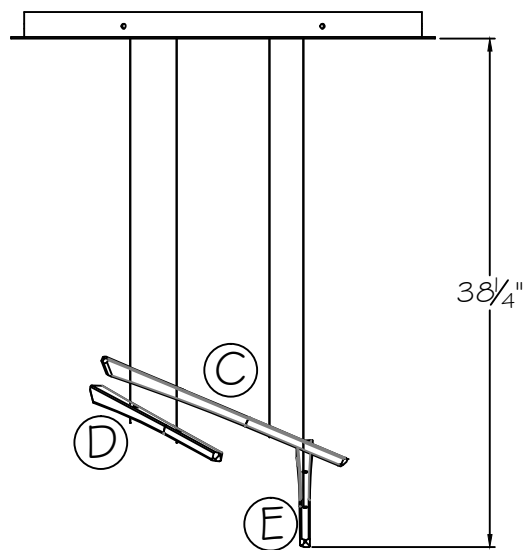

BOTTOM VIEW

- ROW 2 OF GLASSES TO BE INSTALLED FIRST.
- GATHER ALL OTHER CABLES TO EASILY ACCESS LAYER TO BE WORKED ON
- START SLIDING GLASSES UP INTO POSITION AS SHOWN ON FRONT VIEW, STARTING FROM TOP TO BOTTOM
- SLIDE GRIPPER UP TO HOLD POSITION OF GLASS
- NOTE: MULTIPLE GLASSES MAY USE THE SAME CABLES

STYLE(S) #: 895840-132 -232 -142 -242 -152 -252



This drawing, specifications and the product depicted are the exclusive property of Fine Art Handcrafted Lighting®. In compliance with US copyright and patent requirements, notice is hereby given that this document and the product depicted shall not be copied, altered or used in any manner without the expressed written consent of Fine Art Handcrafted Lighting®.

www.finearthl.com

Tel:(305) 821-3850
 FINE ART LAMPING®

Fax:(305) 513-5736

INSTRUCTION #:

00791417

SHEET

2 / 5

INSTRUCTIONS for SPIRES (METEORITE, CRYSTAL STARDUST & EBONY STARDUST)

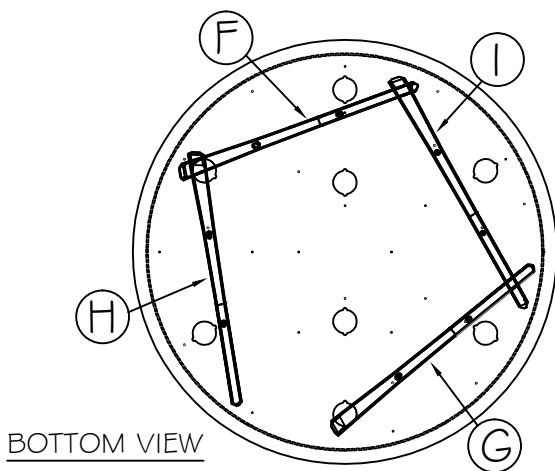
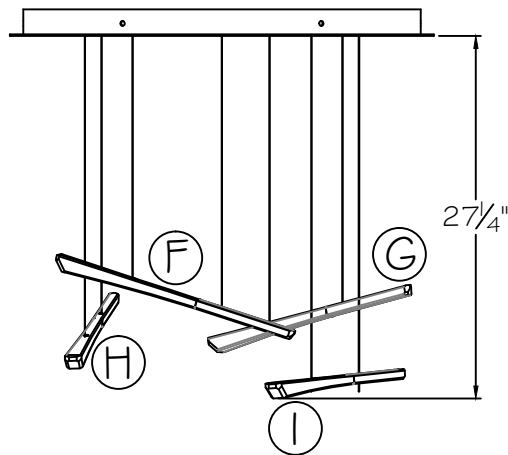
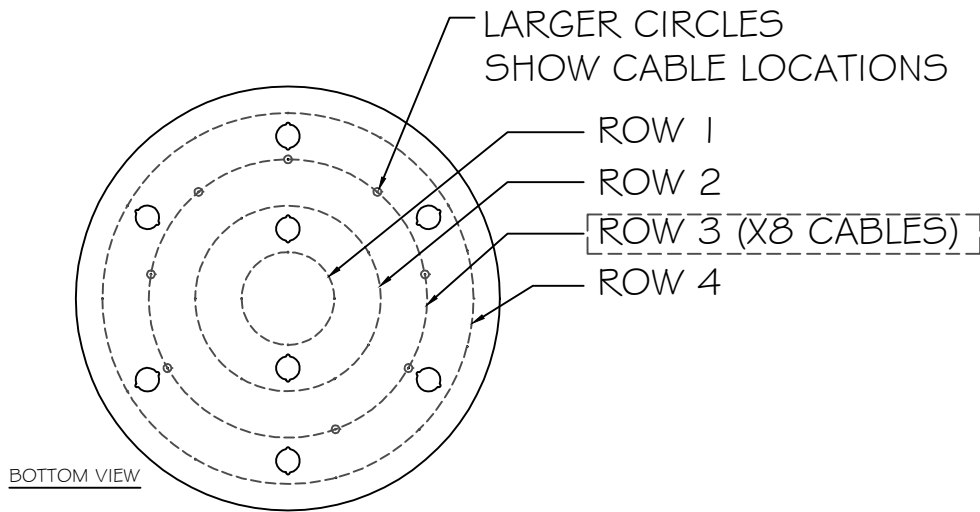

- ROW 3 OF GLASSES TO BE INSTALLED FIRST.
- GATHER ALL OTHER CABLES TO EASILY ACCESS LAYER TO BE WORKED ON
- START SLIDING GLASSES UP INTO POSITION AS SHOWN ON FRONT VIEW, STARTING FROM TOP TO BOTTOM
- SLIDE GRIPPER UP TO HOLD POSITION OF GLASS
- NOTE: MULTIPLE GLASSES MAY USE THE SAME CABLES

STYLE(S) #: 895840-132 -232 -142 -242 -152 -252



This drawing, specifications and the product depicted are the exclusive property of Fine Art Handcrafted Lighting®. In compliance with US copyright and patent requirements, notice is hereby given that this document and the product depicted shall not be copied, altered or used in any manner without the expressed written consent of Fine Art Handcrafted Lighting®.

www.finearthl.com

Tel:(305) 821-3850
FINE ART LAMPS®

Fax:(305) 513-5736

INSTRUCTION #:

00791417

SHEET

3 / 5

INSTRUCTIONS for SPIRES (METEORITE, CRYSTAL STARDUST & EBONY STARDUST)

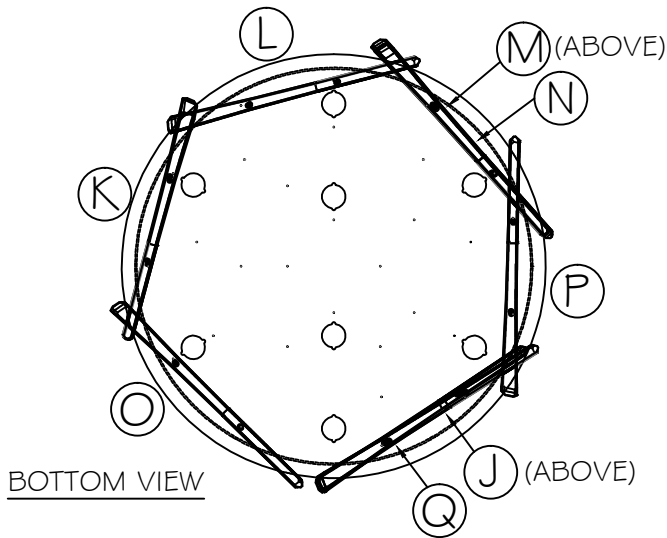
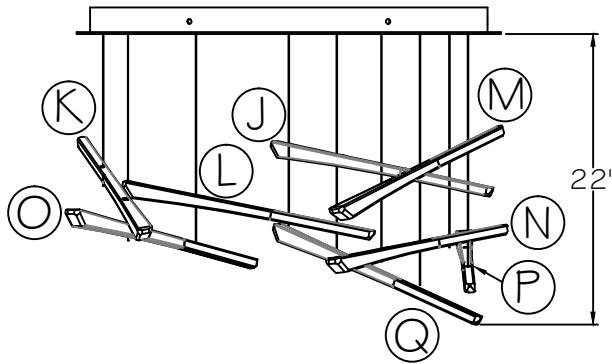
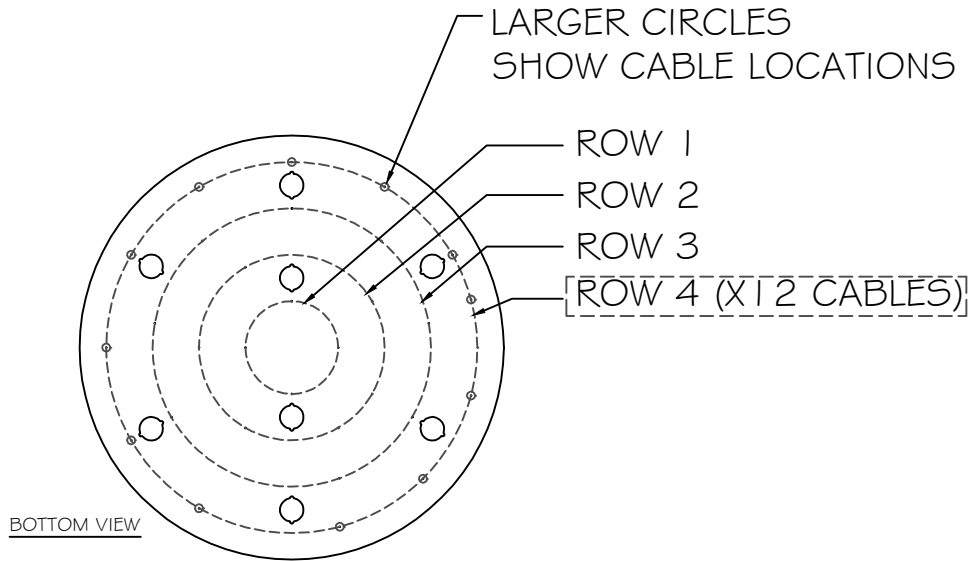

- ROW 4 OF GLASSES TO BE INSTALLED FIRST.
- GATHER ALL OTHER CABLES TO EASILY ACCESS LAYER TO BE WORKED ON
- START SLIDING GLASSES UP INTO POSITION AS SHOWN ON FRONT VIEW, STARTING FROM TOP TO BOTTOM
- SLIDE GRIPPER UP TO HOLD POSITION OF GLASS
- NOTE: MULTIPLE GLASSES MAY USE THE SAME CABLES

STYLE(S) #: 895840-132 -232 -142 -242 -152 -252



This drawing, specifications and the product depicted are the exclusive property of Fine Art Handcrafted Lighting®. In compliance with US copyright and patent requirements, notice is hereby given that this document and the product depicted shall not be copied, altered or used in any manner without the expressed written consent of Fine Art Handcrafted Lighting®.

www.finearthl.com

Tel:(305) 821-3850
FINE ART LAMPS®

Fax:(305) 513-5736

INSTRUCTION #:

00791417

SHEET

4 / 5

INSTRUCTIONS for SPIRES (METEORITE, CRYSTAL STARDUST & EBONY STARDUST)

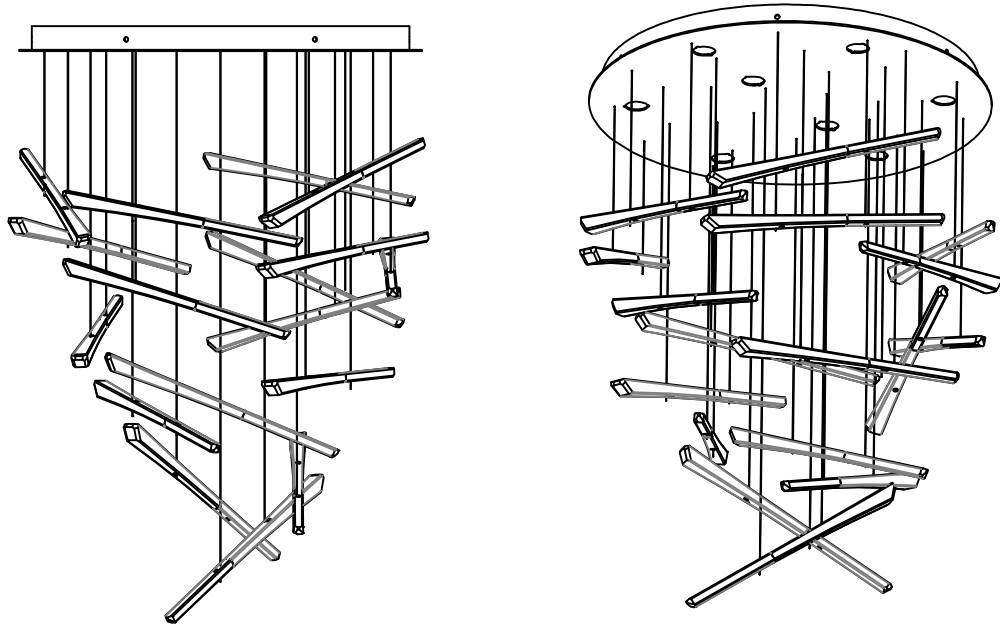

- ONCE ALL GLASSES ARE INSTALLED AND FINAL GLASS POSITION IS ACHIEVED, ENSURE TO CUT EXCESS CABLES UP TO HARDWARE OF LOWEST GLASSES

STYLE(S) #: 895840-132 -232 -142 -242 -152 -252



This drawing, specifications and the product depicted are the exclusive property of Fine Art Handcrafted Lighting®. In compliance with US copyright and patent requirements, notice is hereby given that this document and the product depicted shall not be copied, altered or used in any manner without the expressed written consent of Fine Art Handcrafted Lighting®.

www.finearthl.com

Tel:(305) 821-3850
FINE ART LAMPS®

Fax:(305) 513-5736

INSTRUCTION #:

00791417

SHEET

5 / 5

INSTRUCTIONS for PAGES (FROZEN & BLANK)

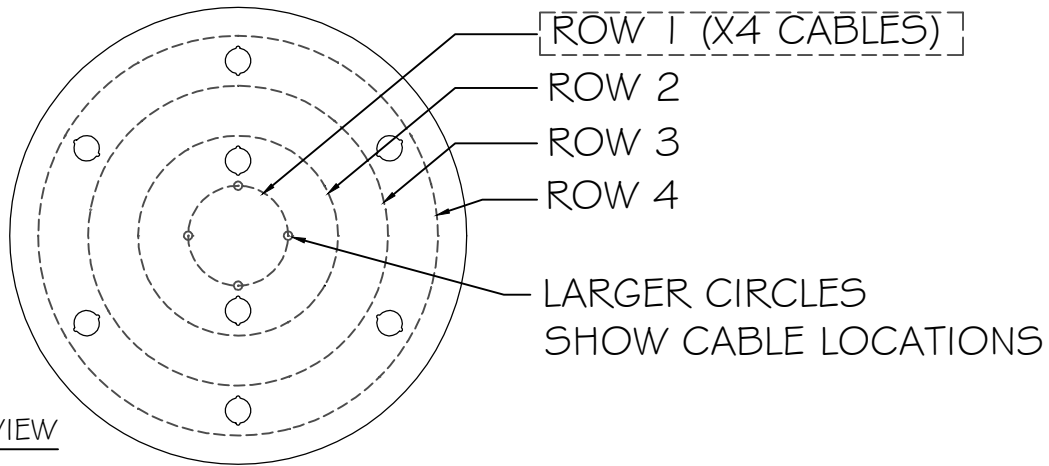

BOTTOM VIEW

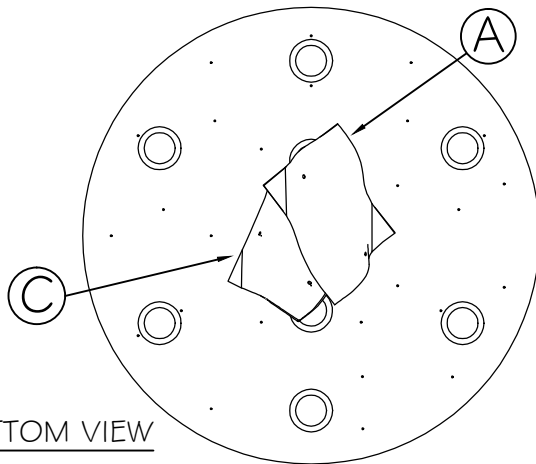
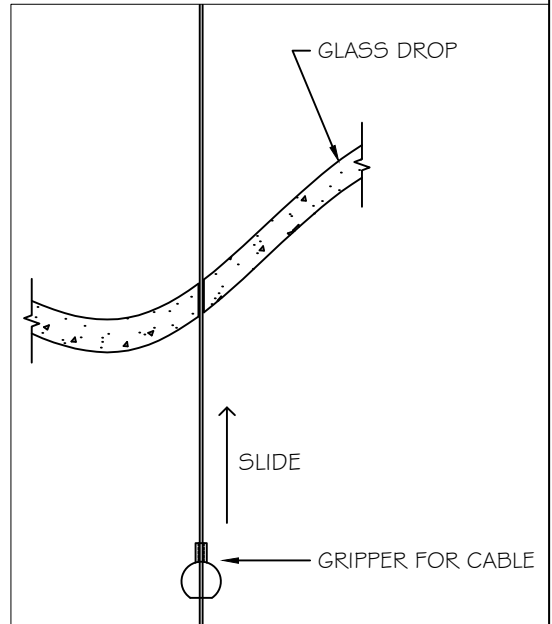
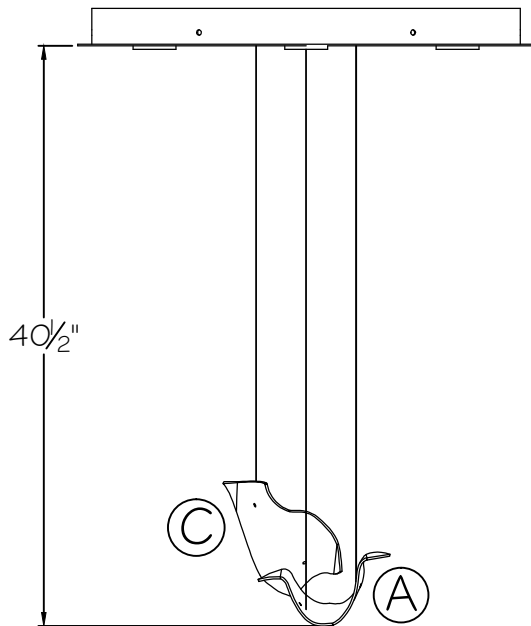

BOTTOM VIEW

ROW 1

GLASS TYPE	QUANTITY
TYPE A	1
TYPE B	0
TYPE C	1

- ROW 1 OF GLASSES TO BE INSTALLED FIRST.
- GATHER ALL OTHER CABLES TO EASILY ACCESS LAYER TO BE WORKED ON
- LETTERS IN CIRCLES ON DIAGRAM INDICATE GLASS TYPE THAT CORRESPONDS TO STICKERS ON GLASS
- START SLIDING GLASSES UP INTO POSITION AS SHOWN ON FRONT VIEW, STARTING FROM TOP TO BOTTOM
- SLIDE GRIPPER UP TO HOLD POSITION OF GLASS
- NOTE: MULTIPLE GLASSES MAY USE THE SAME CABLES

STYLE(S) #: 895840-162 -262 -172 -272



This drawing, specifications and the product depicted are the exclusive property of Fine Art Handcrafted Lighting®. In compliance with US copyright and patent requirements, notice is hereby given that this document and the product depicted shall not be copied, altered or used in any manner without the expressed written consent of Fine Art Handcrafted Lighting®.

www.finearthl.com Tel:(305) 821-3850 Fax:(305) 513-5736
FINE ART LAMPS®

INSTRUCTION #:
00791498

SHEET
1 / 5

INSTRUCTIONS for PAGES (FROZEN & BLANK)

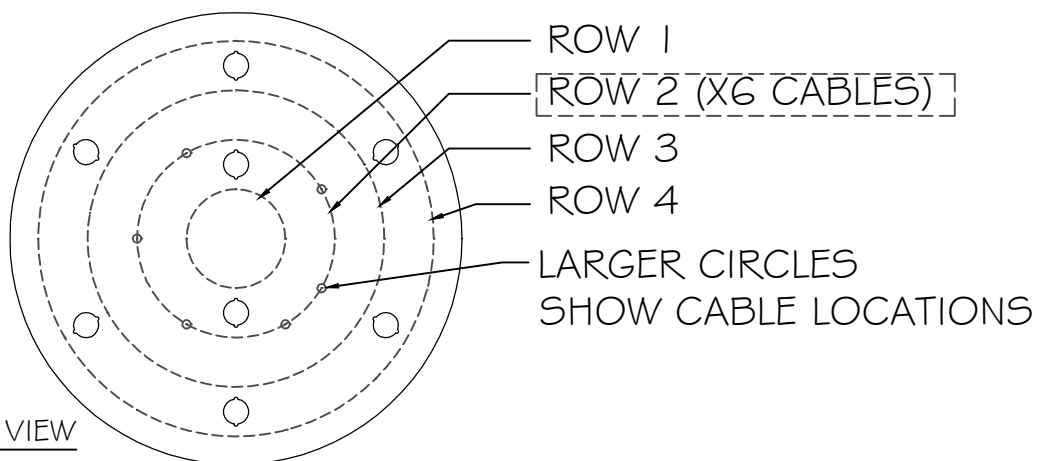

BOTTOM VIEW

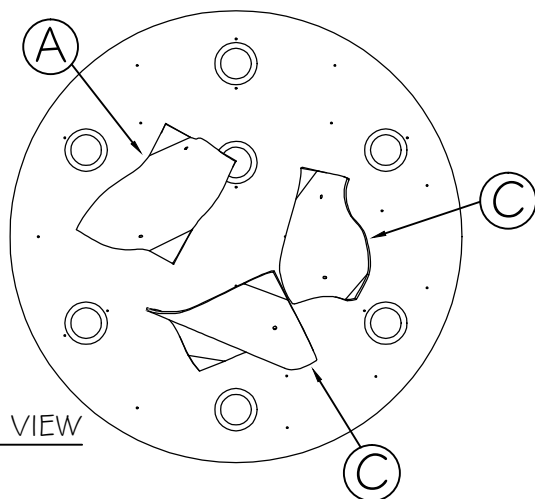
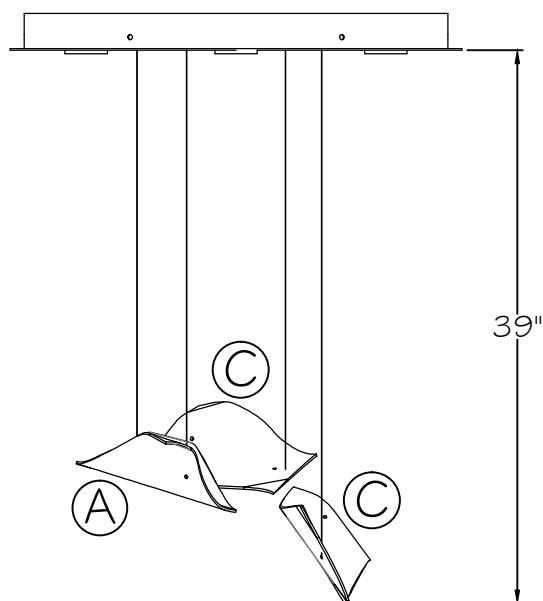

BOTTOM VIEW

ROW 2	
GLASS TYPE	QUANTITY
TYPE A	1
TYPE B	0
TYPE C	2

- ROW 2 OF GLASSES TO BE INSTALLED NEXT.
 - START SLIDING GLASSES UP INTO POSITION AS SHOWN ON FRONT VIEW, STARTING FROM TOP TO BOTTOM
 - SLIDE GRIPPER UP TO HOLD POSITION OF GLASS
 - NOTE: MULTIPLE GLASSES MAY USE THE SAME CABLES

STYLE(S) #: 895840-162 -262 -172 -272



This drawing, specifications and the product depicted are the exclusive property of Fine Art Handcrafted Lighting®. In compliance with US copyright and patent requirements, notice is hereby given that this document and the product depicted shall not be copied, altered or used in any manner without the expressed written consent of Fine Art Handcrafted Lighting®.

www.finearthl.com Tel:(305) 821-3850 Fax:(305) 513-5736
 FINE ART LAMPS®

INSTRUCTION #:
 00791498

SHEET
 2 / 5

INSTRUCTIONS for PAGES (FROZEN & BLANK)

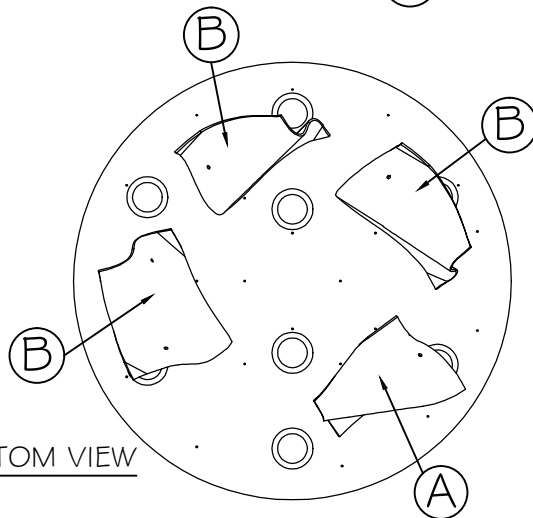
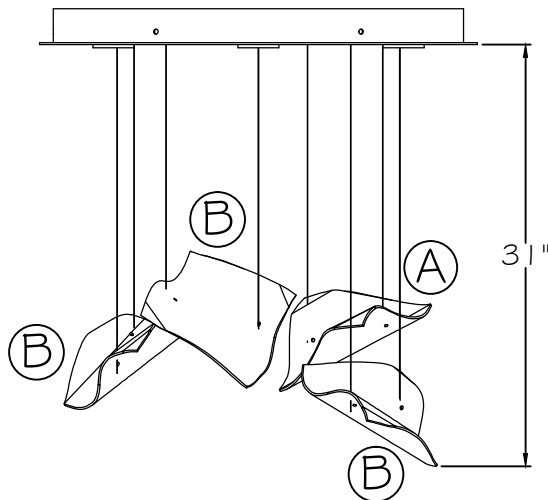
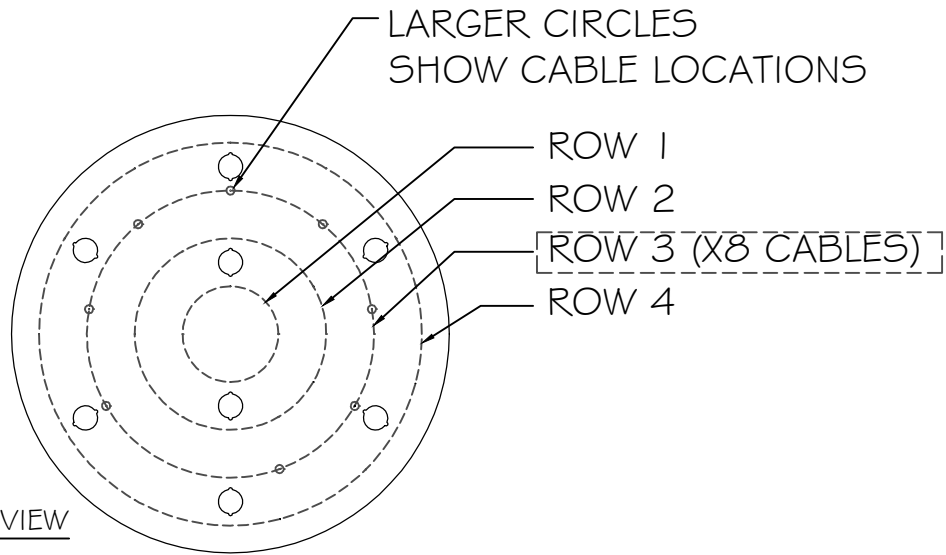

ROW 3	
GLASS TYPE	QUANTITY
TYPE A	1
TYPE B	3
TYPE C	0

- ROW 3 OF GLASSES TO BE INSTALLED NEXT.
- START SLIDING GLASSES UP INTO POSITION AS SHOWN ON FRONT VIEW, STARTING FROM TOP TO BOTTOM
- SLIDE GRIPPER UP TO HOLD POSITION OF GLASS
- NOTE: MULTIPLE GLASSES MAY USE THE SAME CABLES

STYLE(S) #: 895840-162 -262 -172 -272



This drawing, specifications and the product depicted are the exclusive property of Fine Art Handcrafted Lighting®. In compliance with US copyright and patent requirements, notice is hereby given that this document and the product depicted shall not be copied, altered or used in any manner without the expressed written consent of Fine Art Handcrafted Lighting®.

www.finearthl.com

Tel:(305) 821-3850
FINE ART LAMPS®

Fax:(305) 513-5736

INSTRUCTION #:

00791498

SHEET

3 / 5

INSTRUCTIONS for PAGES (FROZEN & BLANK)

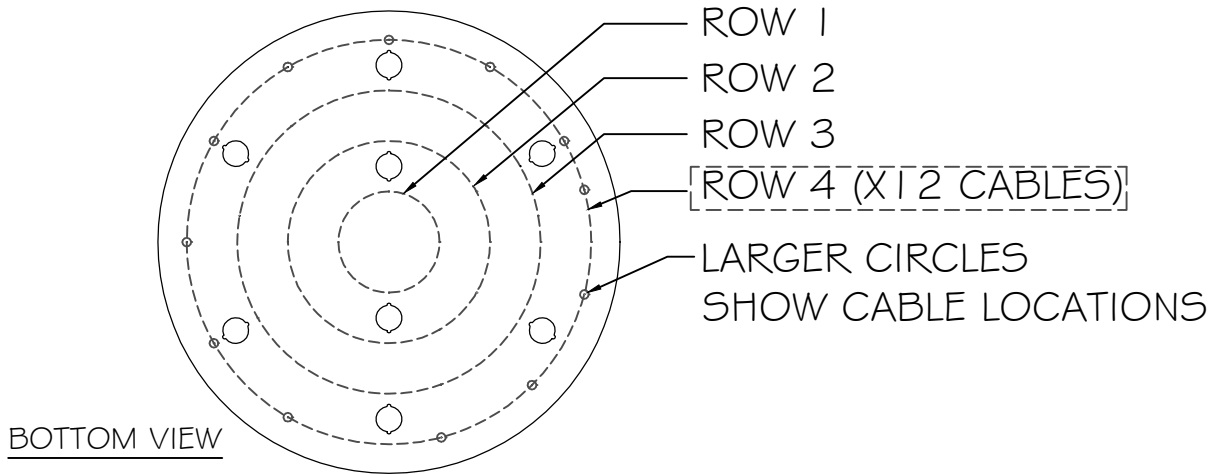

BOTTOM VIEW

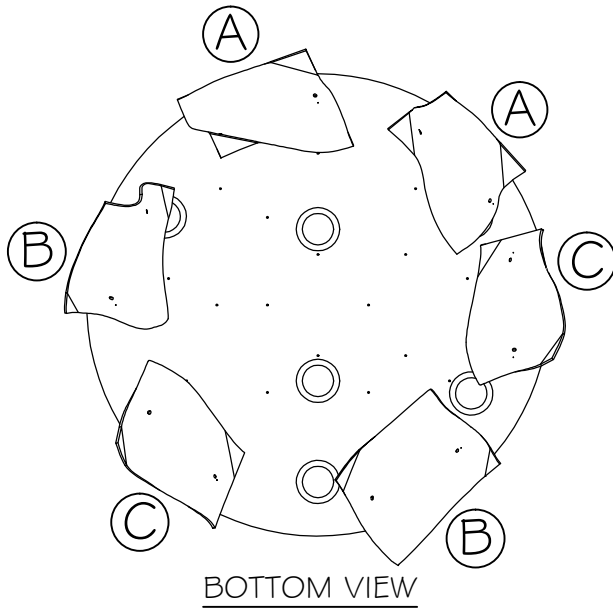
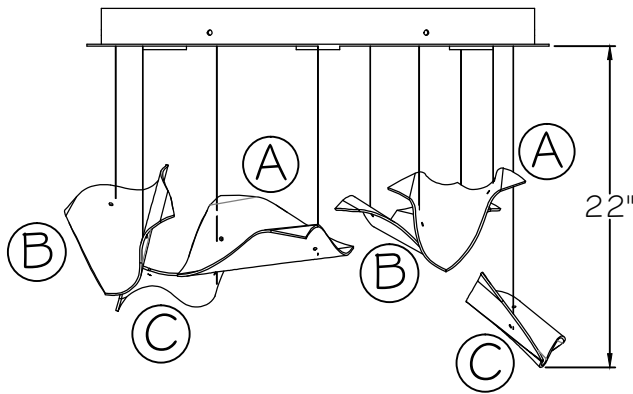

BOTTOM VIEW

ROW 4	
GLASS TYPE	QUANTITY
TYPE A	2
TYPE B	2
TYPE C	2

- ROW 4 OF GLASSES TO BE INSTALLED NEXT.
- START SLIDING GLASSES UP INTO POSITION AS SHOWN ON FRONT VIEW, STARTING FROM TOP TO BOTTOM
- SLIDE GRIPPER UP TO HOLD POSITION OF GLASS
- NOTE: MULTIPLE GLASSES MAY USE THE SAME CABLES

STYLE(S) #: 895840-162 -262 -172 -272



This drawing, specifications and the product depicted are the exclusive property of Fine Art Handcrafted Lighting®. In compliance with US copyright and patent requirements, notice is hereby given that this document and the product depicted shall not be copied, altered or used in any manner without the expressed written consent of Fine Art Handcrafted Lighting®.

www.finearthl.com Tel:(305) 821-3850 Fax:(305) 513-5736
FINE ART LAMPS®

INSTRUCTION #:
00791498

SHEET
4 / 5

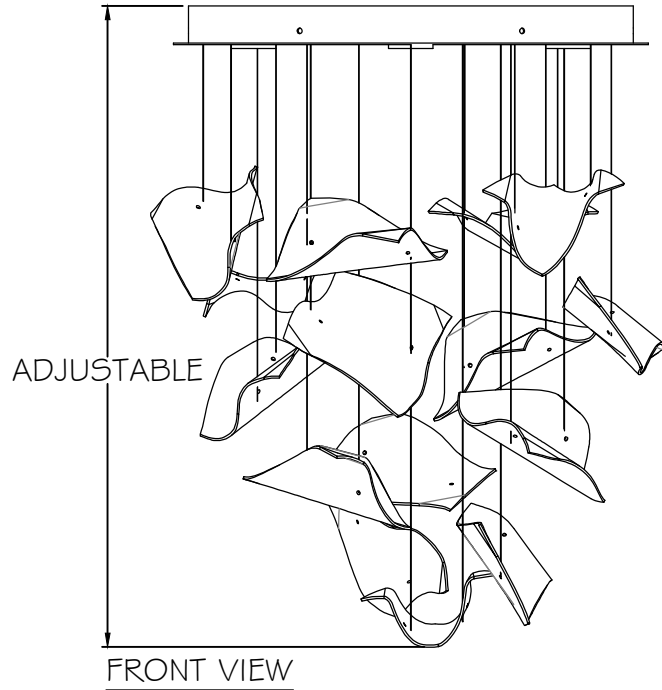
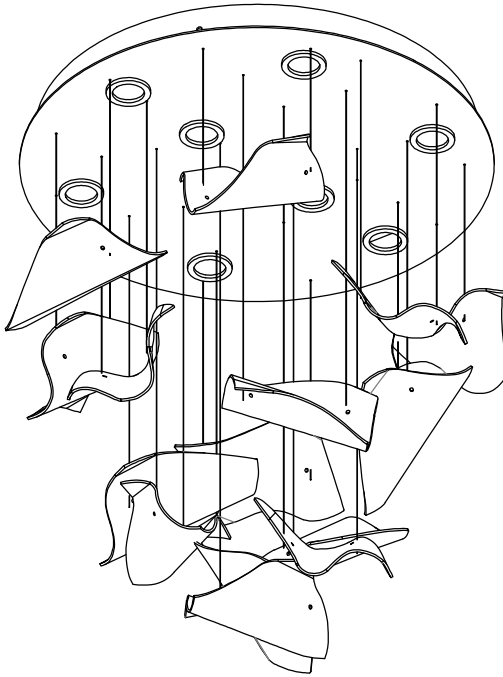

- ONCE ALL GLASSES ARE INSTALLED AND FINAL GLASS POSITION IS ACHIEVED, ENSURE TO CUT EXCESS CABLES UP TO HARDWARE OF LOWEST GLASSES. REFERENCE INSTALLATION INSTRUCTIONS.

STYLE(S) #: 895840-162 -262 -172 -272



This drawing, specifications and the product depicted are the exclusive property of Fine Art Handcrafted Lighting®. In compliance with US copyright and patent requirements, notice is hereby given that this document and the product depicted shall not be copied, altered or used in any manner without the expressed written consent of Fine Art Handcrafted Lighting®.

www.finearthl.com

Tel:(305) 821-3850
FINE ART LAMPS®

Fax:(305) 513-5736

INSTRUCTION #:

00791498

SHEET

5 / 5