

Installation Instructions

For Sconce 20-4790

B198

Page 1 of 2

CAUTION: FAILURE TO INSTALL THIS FIXTURE PROPERLY MAY RESULT IN SERIOUS PERSONAL INJURY OR DEATH AND PROPERTY DAMAGE. We recommend installation by a licensed electrician.

This product must be installed in accordance with applicable installation code(s), by a person familiar with the construction and operation of the product and the hazards involved.*

Caution: Do not exceed maximum wattage noted on fixture. Use only recommended bulbs with fixture.

Please Note: This fixture is designed to be mounted on a standard wall surface and may not be suitable for all applications. If installing in a non-wood frame application, we recommend consulting a qualified builder or electrician.

To Mount Fixture to Wall (Figure 1)

Component Parts

- A Crossbar
- B 8-32 Screws (2)
- C Cupped Washer
- D Ground Screw

Caution: Be sure power is off at the main breaker box prior to installation.

1. Carefully unpack the fixture from the carton.
2. Using two machine screws (not provided), fasten the crossbar (A) to the electric box making sure that fixture mounting holes are level.
Note: A new electric box comes with screws. When replacing a fixture, retain the existing screws for use with the new fixture.
3. Hold the fixture close to the wall and using suitable wire connectors, not provided, connect fixture wires to supply (white to white or ribbed and black to black or smooth). Ground using the green ground screw (D) and cupped washer (C) to secure a pigtail lead to the crossbar (A).
Caution: Make sure wire connectors are twisted on securely, and no bare wire is exposed.
4. Carefully tuck all wires behind the fixture, place fixture firmly against the wall and fasten with two 8-32 screws (B).
5. See instructions following to install bulb and glass.

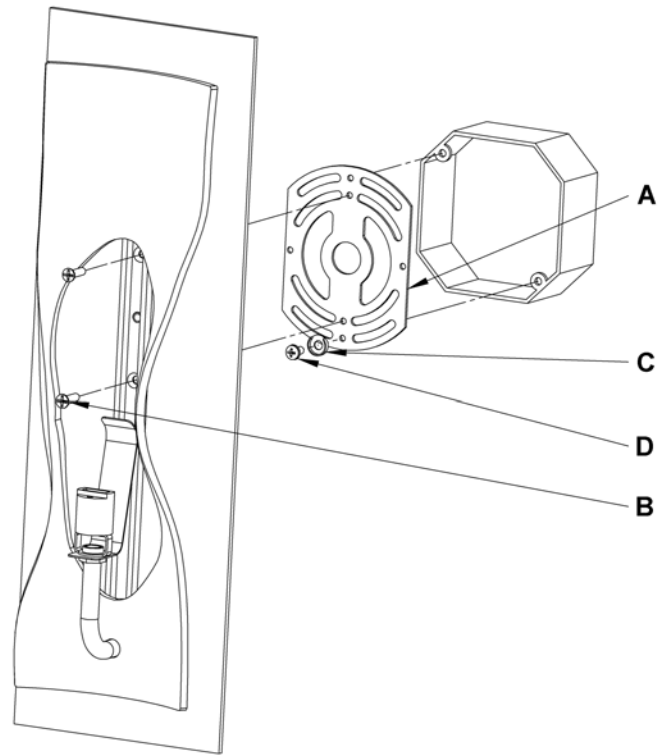

(Figure 1)

(continued)

Installation Instructions

For Sconce 20-4790

B198

Page 2 of 2

To Install Glass (Figure 2)

Component Parts

- E Socket
- F Bulb (Included)
- G Glass
- H Glass Spring Clip
- I Wireway
- J Forged Front Plate

1. Install light bulb (F). Be careful not to touch bulb with bare hands; oil from the hands will dramatically reduce bulb life.
2. Slip glass (G) with slot pointing down through forged front plate until it engages with glass spring clip (H).
3. Pull glass (G) slightly forward to clear bottom of the forged plate. Align slot in glass (G) so it slips onto wireway (I).
4. Restore electricity at main breaker.

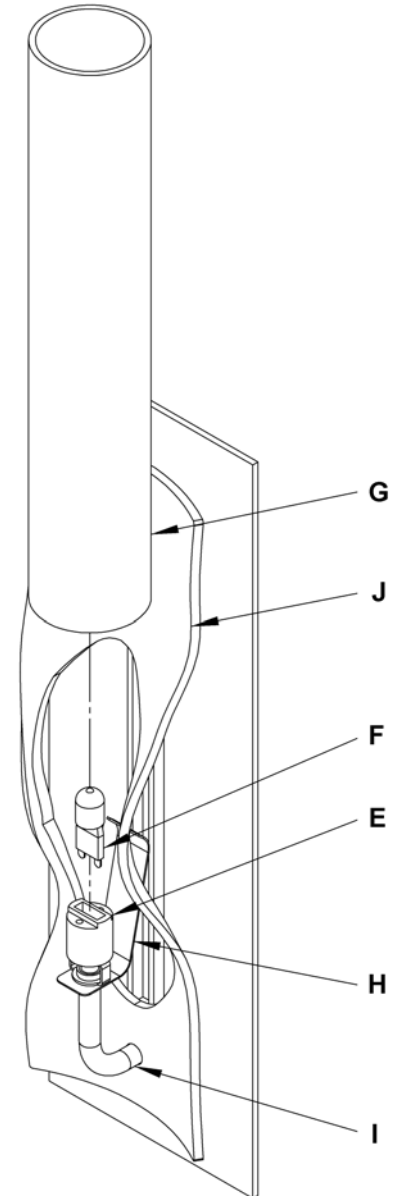

(Figure 2)

If you need further assistance, or find that you are missing any parts, please contact the dealer from which you purchased this product. We hope you enjoy your fixture!

* Hubbardton Forge will not be liable for injury or damage caused by improper installation, lamping or use of this fixture.