

hollis+morris

constellation
SCONCE
product installation + specifications

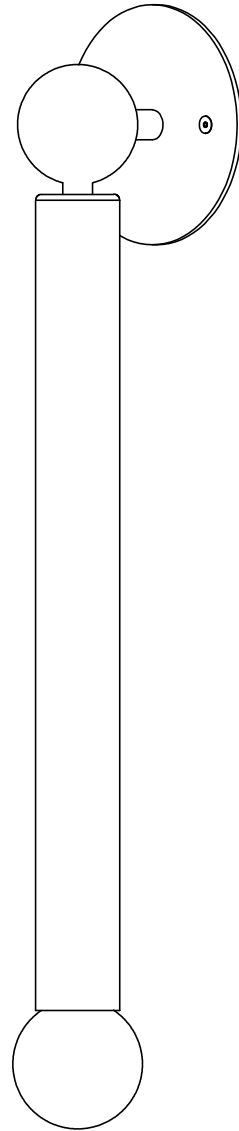

constellation sconce

PRODUCT CODE
CONSsconce

MATERIALS

- + Solid wood
- + Hand blown glass
- + Metal
- + G9 LED light bulb

FINISH

- + Hard wax oil

INPUT

- + 120V 50/60 Hz (Canada + US)

OUTPUT

- + 4.5W
- + 450 lumens
- + 3000K with CRI of 85 or higher

MOUNTING

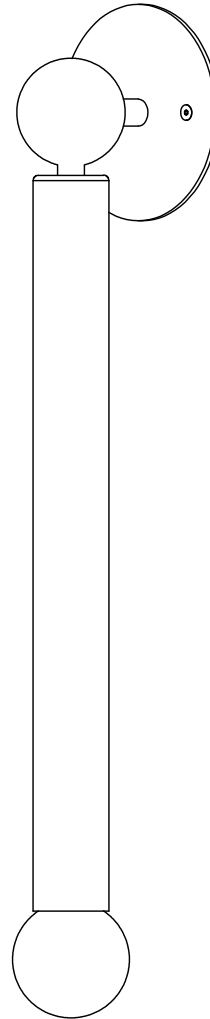

- + J-box connection



certification:



hardware components list

Component	Quantity	
Constellation Sconce	1	
8-32, 1" Flat Head Screw	2	

dimensions + installation

1. Locate desired mounting location on wall.
2. Have a certified electrician connect +/- leads into 120 V domestic power.
3. Attach fixture to junction box with provided 8-32 screws.

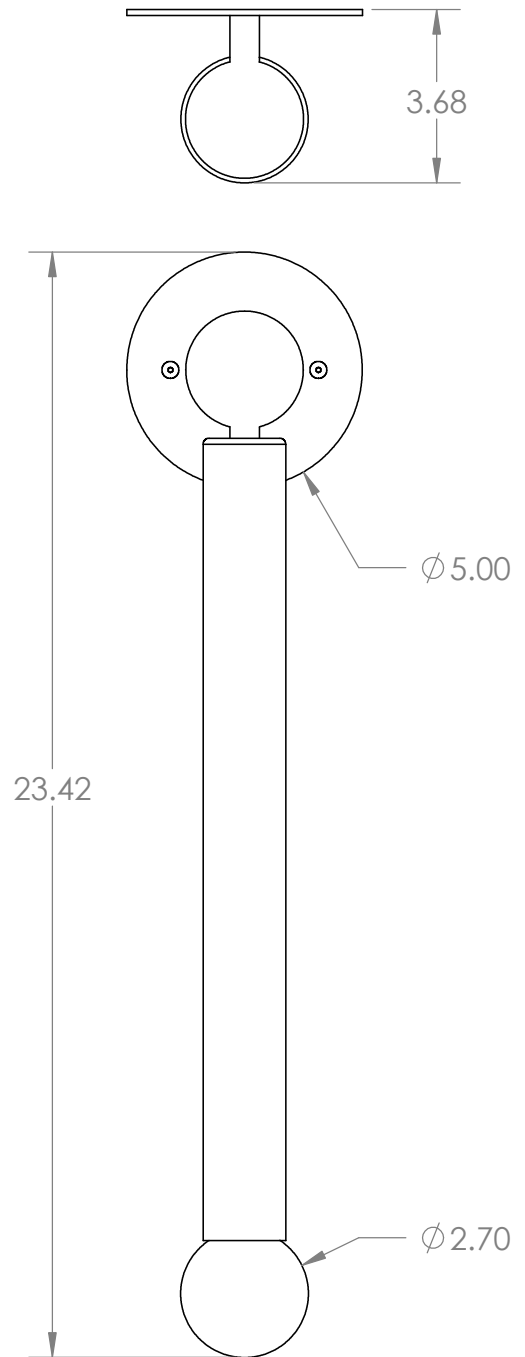
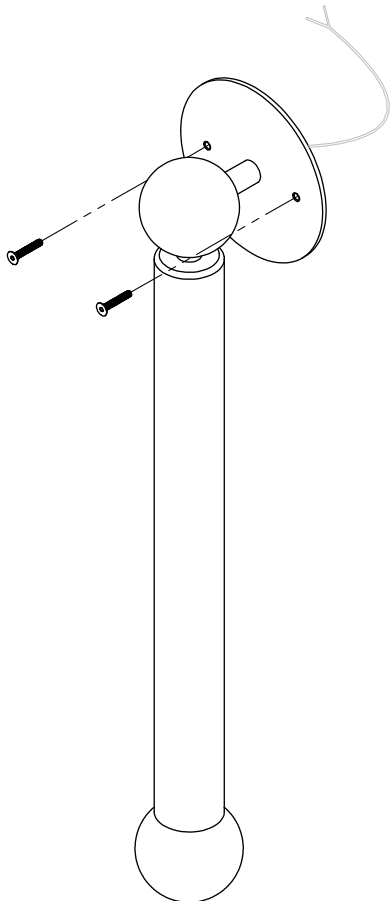

hardware replacement

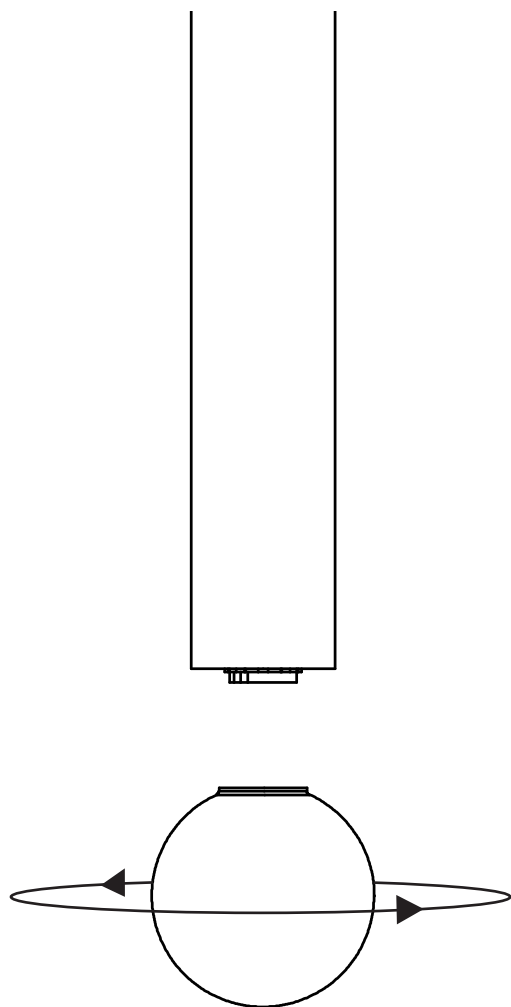

1. Unscrew glass bulb from wood top
2. Remove G9 LED bulb from socket by gently pulling
3. Insert a new G9 LED bulb
4. Screw glass bulb onto wood top