

# Installation Instructions

C52

For Contract Antasia Table Lamps 272803 & 272803C

Page 1 of 2

## To Install Shade (Figures 1 & 2)

### Component Parts

- A Shade
- B Diffuser
- C Washer
- D Finial
- E Harp
- F Harp Holder

1. Carefully unpack the lamp from the carton.
2. Remove finial (D) and washer (C) from threaded stud on harp (E) and save for later use. *Finial and washer are shipped installed.*
3. Squeeze harp (E) together while holding the locks up towards the top of the harp (E) and slip into harp holder (F) (Figure 1).
4. Allow locks to slip down harp (E) and onto harp holder (F) to secure harp in place.
5. Install bulbs. "C" version bulbs are included.
6. Slip shade (A), diffuser (B) and washer (C) onto threaded stud on top of harp (E). See Figure 2 for washer orientation.
7. Thread finial (D) onto threaded stud on harp (E) and tighten until snug. *Be careful not to over tighten.*

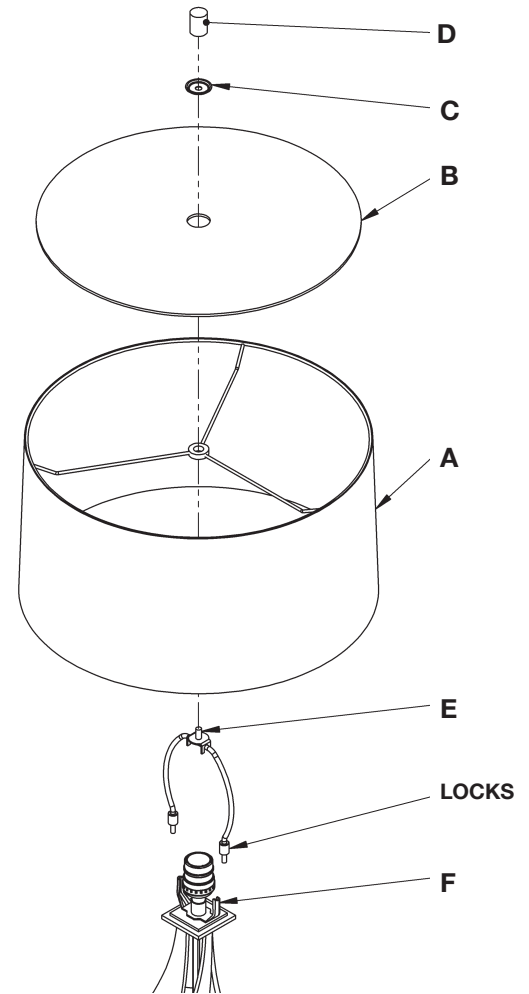

(Figure 1)

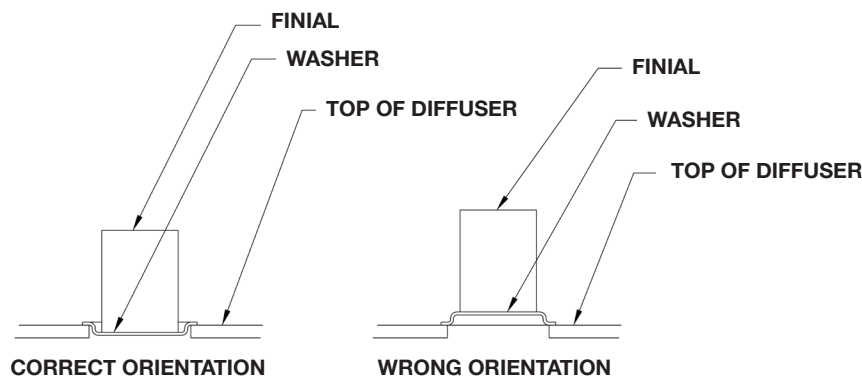

(Figure 2)

(Continued)

If you need further assistance, or find that you are missing any parts, please contact the dealer from which you purchased this product. We hope you enjoy your fixture!

\* Hubbardton Forge will not be liable for injury or damage caused by improper installation, lamping or use of this fixture.

# Installation Instructions

C52

For Contract Antasia Table Lamps 272803 & 272803C

Page 2 of 2

## To Use Bolt-Down Option (Figures 3 & 4)

### Component Parts

- G Fixture Base
- H Nipple
- I Washer
- J Hex Nut

1. Thread nipple (H) into coupling in bottom of fixture base (G).
2. In the surface that the lamp will bolt to, drill a 7/16" diameter hole for nipple (H) to slip through. See Figure 4 for alignment.
3. Slide nipple (H) through hole and make sure fixture base (G) is flush with the surface.
4. On the bottom side of the surface, place the washer (I) onto the nipple (H) and thread on the hex nut (J). Tighten to secure the lamp.

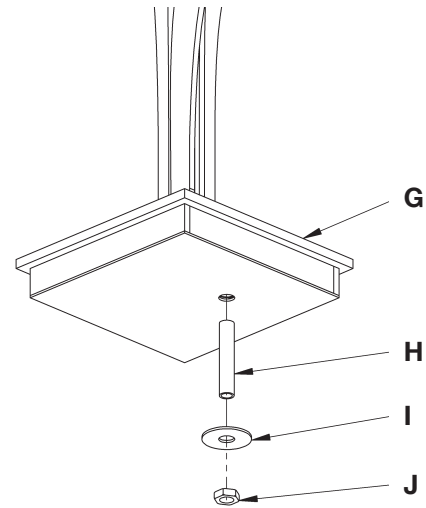

(Figure 3)

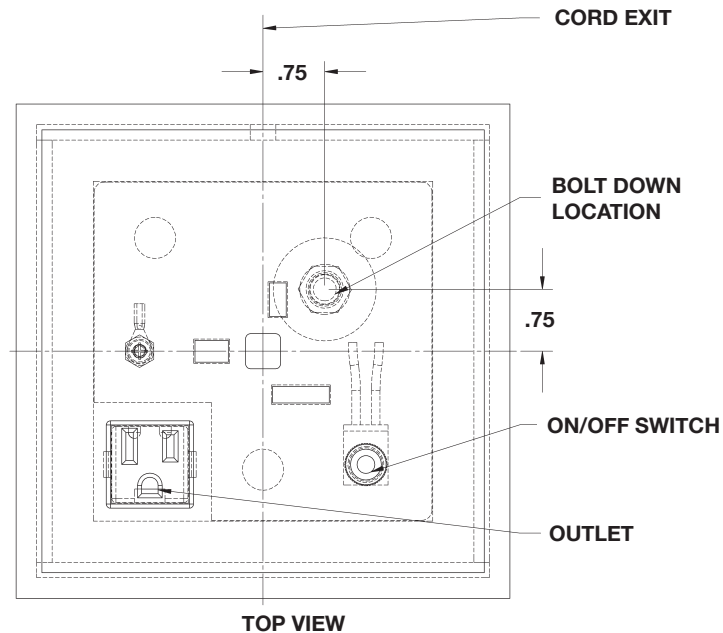

(Figure 4)

If you need further assistance, or find that you are missing any parts, please contact the dealer from which you purchased this product. We hope you enjoy your fixture!

\*Hubbardton Forge will not be liable for injury or damage caused by improper installation, lamping or use of this fixture.