

# CRYSTORAMA

LIGHTING THE WAY FOR SIXTY YEARS

ASSEMBLY INSTRUCTION MODEL #HAY-1405-PN



All electrical components must be installed by a licensed electrician in accordance with the National Electric Code and the appropriate local electrical codes.



You will need 12-Candelabra Base Bulb  
40 Watts Recommended 60 Watts Max

**USE LED BULBS FOR EXTENDED USE**

**This fixture is Dry rated**

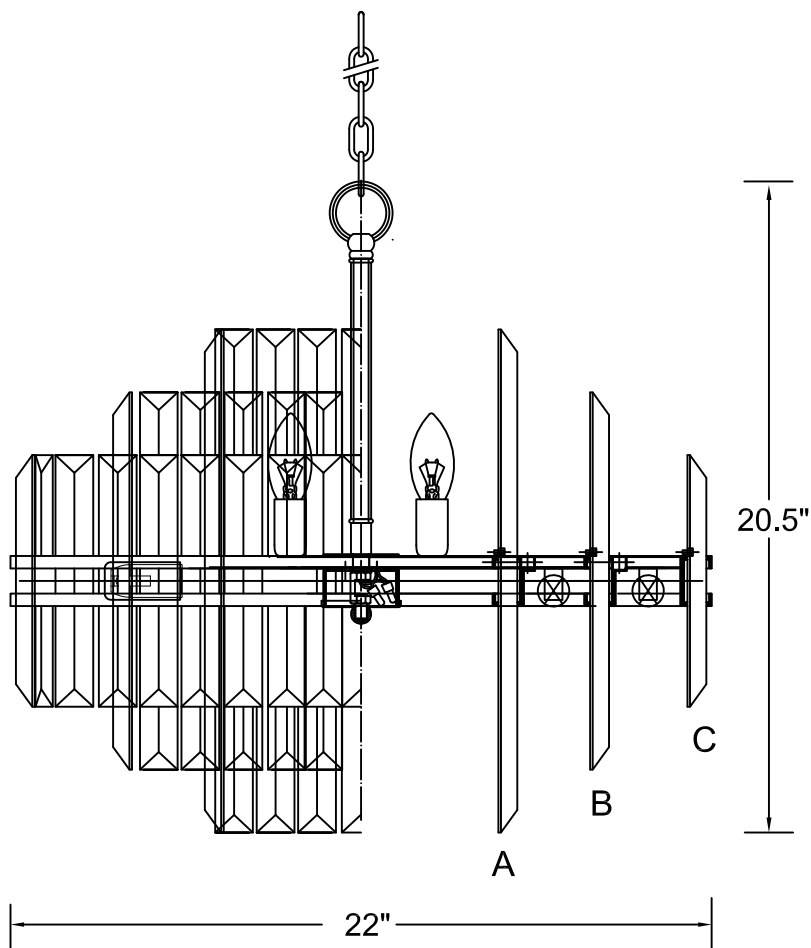

### How to Install

1. Do a complete inventory of all parts and components before you start installing.
2. Slide one check ring over the coupler on top of frame. Screw the threaded pipe into the coupler and slide the metal tube over the threaded pipe. Slide another check ring over the top of metal tube and secure with fixture loop.
3. After safely attaching fixture into outlet box, install bulbs (not included) and proceed to connecting the power.
4. When you begin to dress the fixture, start with crystal labeled (A).
5. **IMPORTANT:** Apply crystal sets in alphabetical order.

### DETAILED ILLUSTRATION

### Crystal Sets

- A. 18Sets. (1)30x400mm
- B. 30Sets. (1)30x300mm
- C. 42Sets. (1)30x200mm

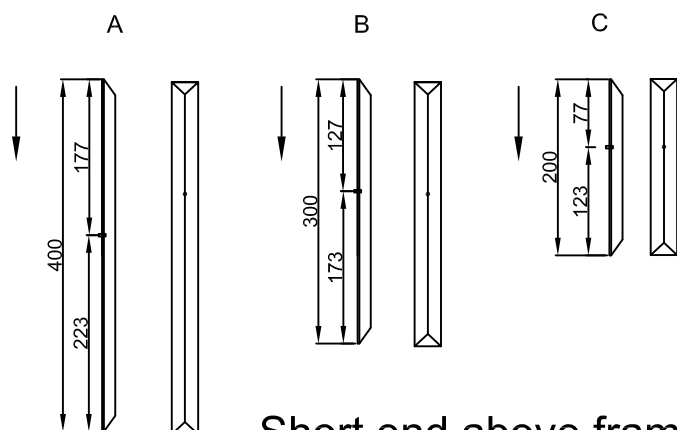

**WARNING:** This product can expose you to Lead, which is known to the State of California to cause cancer and/or birth defects or reproductive harm. For more information go to [www.P65Warnings.ca.gov](http://www.P65Warnings.ca.gov)

# CRYSTORAMA

LIGHTING THE WAY FOR SIXTY YEARS

PART NUMBER MODEL #HAY-1405-PN

## Part Number

### Part Numbers

- A. (2)-Wire Connector
- B. (1)-Mounting Plate
- C. (2)-Outlet Box Screws
- D. (1)-Lock washer
- E. (1)-Hex Nut
- F. (1)-Nipple
- G. (1)-Canopy; w5" x h1.25" (XFB1405PNCAN5IN)
- H. (1)-Collar Ring
- I. (1)-Collar Loop
- J. (1)-Chain; 72", 4mm (XFB1405PNCHA4MM)
- K. (1)-Ground Wire
- L. (1)-Fixture Loop
- M. (1)-Metal Tube; 8.5", 16MM thickness
- N. (1)-Threaded Pipe; 9.5", 12MM thickness
- O. (2)-Check Ring
- P. (1)-Frame

PART BAG I : Includes Parts A, C

PART BAG II : Includes Parts B, D, E, F, H, I

