

Assembly & Installation Instructions

A136

For Ellipse Pendants 13-7523 & 137523F

Page 1 of 4

CAUTION: FAILURE TO INSTALL THIS FIXTURE PROPERLY MAY RESULT IN SERIOUS PERSONAL INJURY OR DEATH AND PROPERTY DAMAGE. We recommend installation by a licensed electrician.

This product must be installed in accordance with applicable installation code(s), by a person familiar with the construction and operation of the product and the hazards involved.*

Caution: Do not exceed maximum wattage noted on fixture. Use only recommended bulbs with fixture.

To Attach Fixture Pipes (Figure 1)

Component Parts

- A Fixture Pipe
- B Fixture Coupling

1. Carefully unpack the fixture from the carton.
2. Carefully thread fixture pipe (A), threaded end first, over fixture wires.
3. Apply a drop of the supplied thread locking compound to the internal threads at the top of the fixture (B) and screw stem into fixture, being careful not to twist the wires.

Note: Application of the thread locking compound is necessary to prevent the stem from loosening during regular maintenance and cleaning of the fixture. Be certain to apply the compound.

4. See instructions below to complete the installation.

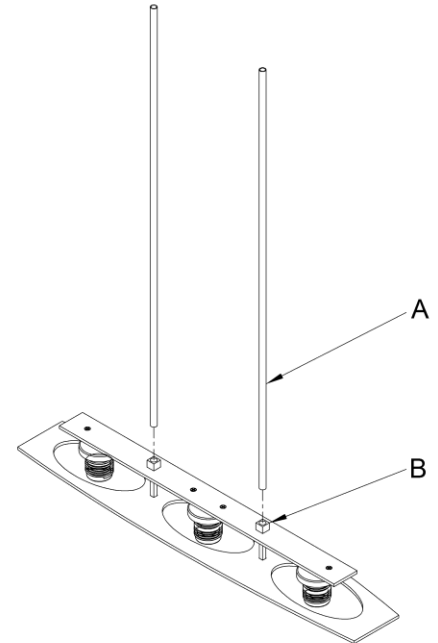

(Figure 1)

To Assemble Canopy Pipes to Ceiling Bracket (Figure 2)

Component Parts

- C Hex Nipple (2)
- D Lock Washer (2)
- E Ceiling Bracket
- F Canopy Pipes (2)

1. Insert threaded end of hex nipple (C) down through lock washer (D), ceiling bracket (E) and into swivel at the end of canopy pipe (F).
2. Tighten securely being sure the notches in the swivels are aligned.

Note: If installing on a sloped ceiling, make certain that the notches in the swivel portion of the stems are oriented toward the lower side of the slope.

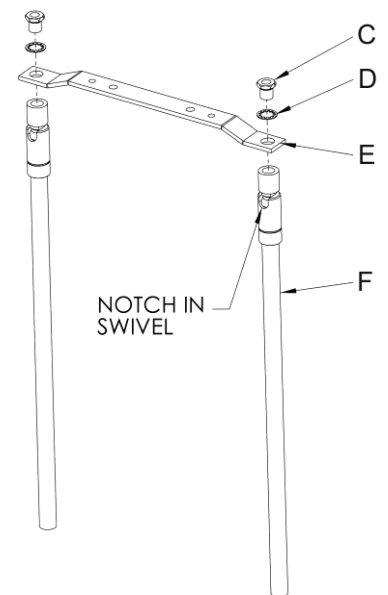

(Figure 2)

(continued)

Assembly & Installation Instructions

For Ellipse Pendants 13-7523 & 137523F

A136

Page 2 of 4

To Complete Fixture Assembly (Figures 3 & 4)

Component Parts

- | | | | |
|---|------------------|---|---------------------------|
| A | Fixture Pipe (2) | H | Plastic Clutch Sleeve (2) |
| C | Hex Nipple | I | Set Screw (2) |
| F | Canopy Pipe (2) | J | Canopy |
| G | Clutch (2) | | |

Caution: Be sure power is off at the main breaker box prior to installation.

1. Thread wires from the fixture pipe (A) through canopy (J). Slide canopy (J) down fixture pipe (A) until it rests on top of fixture.
2. Thread the wires from the fixture pipe (A) into and through the canopy pipe (F) up through the hex nipple (C).
3. Unscrew the clutch (G) from the canopy pipe (F); slide it across the wires and onto the fixture pipe (A). Follow this with the plastic clutch sleeve (H), oriented so the tapered end of the clutch sleeve nests in the clutch (Figure 3).
4. Slide the canopy pipe (F) as far as necessary to give you the total length of the fixture which you desire. Be careful not to scratch the pipe surfaces and to pull excess wire up through the canopy pipe (F). Screw clutch (G) onto canopy pipe (F). There must be a minimum 1-1/2" of inner pipe inside the outer pipe. Hand-tighten the clutch to temporarily hold this adjustment. The clutch is not securely fastened at this point; do not depend on it to hold the fixture.
5. Tighten the set screw (I) firmly with hex wrench provided. Only after the set screw (I) is tight should you install to the ceiling.
6. Continue with Ceiling Installation.

Important: To ensure full connection strength, be sure the tapered end of the plastic clutch sleeve is oriented toward the clutch when assembled. (Figure 3).

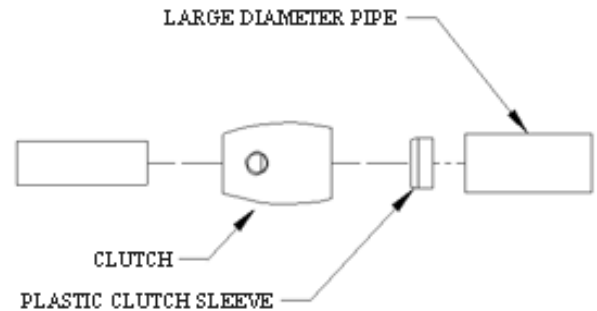

(Figure 3)

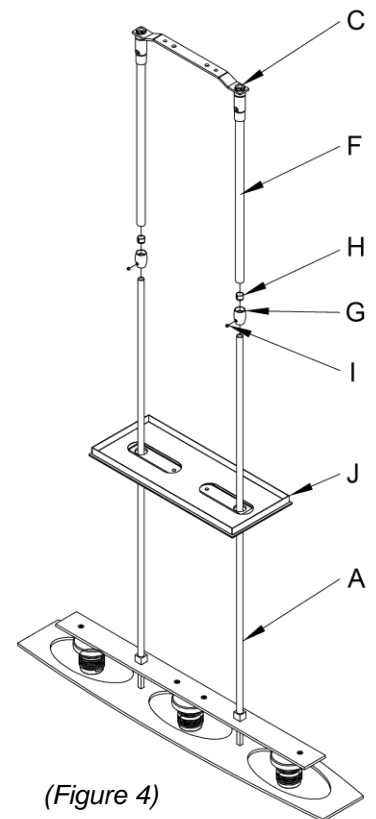

(Figure 4)

(continued)

Assembly & Installation Instructions

For Ellipse Pendants 13-7523 & 137523F

A136

Page 3 of 4

To Install to Ceiling (Figure 5)

Component Parts

E Ceiling Bracket	L Crossbar	O Threaded Stud (2)
I Set Screw (2)	M Stud (2)	P Hex Nut (2)
J Canopy	N Lag Screw (4)	Q Barrel Knob (2)

1. Thread studs (O) through appropriate holes in crossbar (L) to match holes in canopy (J).
2. Using two machine screws (not provided) fasten crossbar (L) to the electric box using tab holes to orient fixture to desired hanging position. **Note:** A new electric box comes with screws. When replacing an existing fixture, retain the screws for use with the new fixture.

Alternate Mounting Option - Using four lag screws (N) attach crossbar (L) to a structural member in the ceiling, centering the crossbar over the outlet box. We've supplied lag screws with your fixture; however, different materials and/or construction methods may require different fasteners. If in doubt, contact a qualified electrician.

3. Raise fixture to ceiling aligning studs in crossbar (L) with holes in ceiling bracket (E).
4. Thread hex nut (P) onto studs (M) and tighten.
5. Using suitable wire connectors (not provided) connect fixture wires to supply (white to white and black to black, and bare copper to bare copper or green supply). Push wires back into outlet box.
6. Raise canopy (J) to ceiling over threaded studs (O) and push firmly to ceiling, making sure that no wires are pinched between canopy and ceiling. Fasten with barrel knob (Q).

Note: Be sure both swivel notches are aligned in the same direction. For sloped ceilings the notches should face towards the down side.

7. Refer to instructions for installing glass.

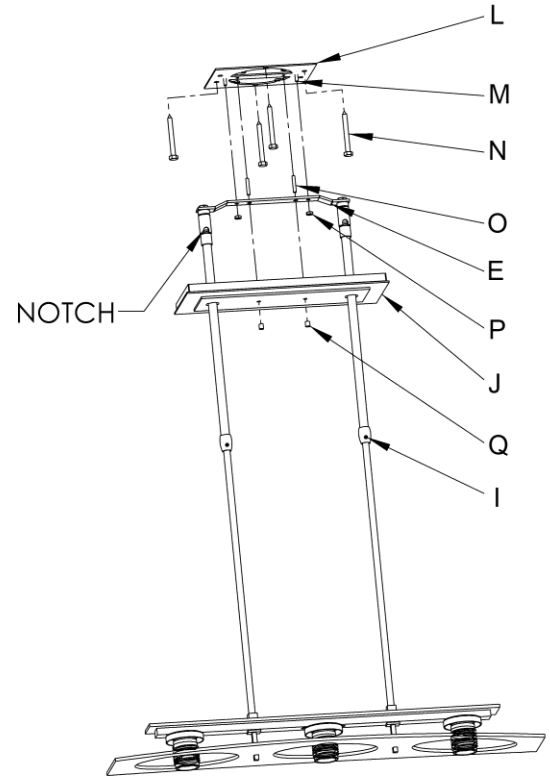

(Figure 5)

Assembly & Installation Instructions

For Ellipse Pendants 13-7523 & 137523F

A136

Page 4 of 4

To Install Glass (Figure 6)

Component Parts

- R Socket (3)
- S Glass (3)
- T Retaining Ring (3)
- U Socket Tool

1. Remove retaining rings (T) from sockets (S). Retaining rings are shipped installed on product.
2. Slip glass (S) over socket (R).
3. Thread retaining ring (T) onto socket using socket tool provided (U) until it rests on inside of glass (S). Do not over tighten.
4. Install light bulbs and restore electricity at main breaker.

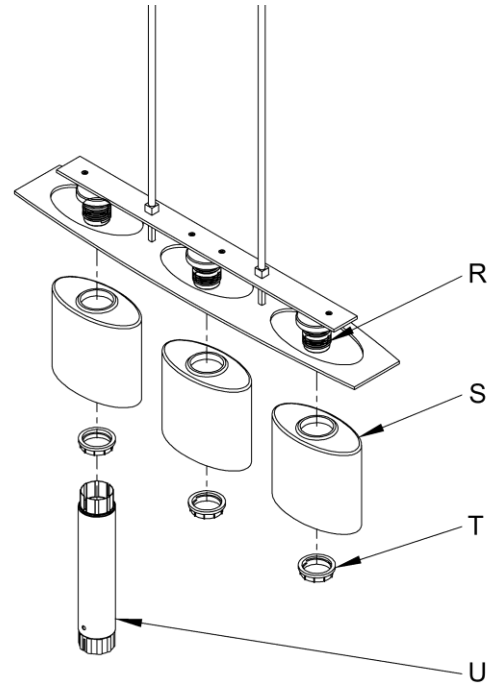

(Figure 6)

If you need further assistance, or find that you are missing any parts, please contact the dealer from which you purchased this product. We hope you enjoy your fixture!

* Hubbardton Forge will not be liable for injury or damage caused by improper installation, lamping or use of this fixture.