

# Assembly & Installation Instructions

Erlenmeyer Kitchen Pendant 18720

**A400**

Page 1 of 3

**CAUTION: FAILURE TO INSTALL THIS FIXTURE PROPERLY MAY RESULT IN SERIOUS PERSONAL INJURY OR DEATH AND PROPERTY DAMAGE. We recommend installation by a licensed electrician.**

This product must be installed in accordance with applicable installation code(s), by a person familiar with the construction and operation of the product and the hazards involved.\*

**Caution:** Do not exceed maximum wattage noted on fixture. Use only recommended bulbs with fixture.

## Stem Assembly (Figure 1)

### Component Parts

- A Fixture Pipe
- B Fixture Coupling

1. Carefully unpack the fixture from the carton.
2. Carefully slip fixture pipe (A), threaded end first, over fixture wires.
3. Feed braided sleeving through fixture coupling (B) and into the end of the fixture pipe (A). Allow approximately 8 1/2" of slack (between the fixture coupling (B) and socket cup) in the braiding to allow for adjustment of the fixture angle.
4. Apply a drop of the supplied thread locking compound to the threads of fixture pipe (A) and screw pipe into fixture coupling (B), being careful not to twist or pinch the wires.

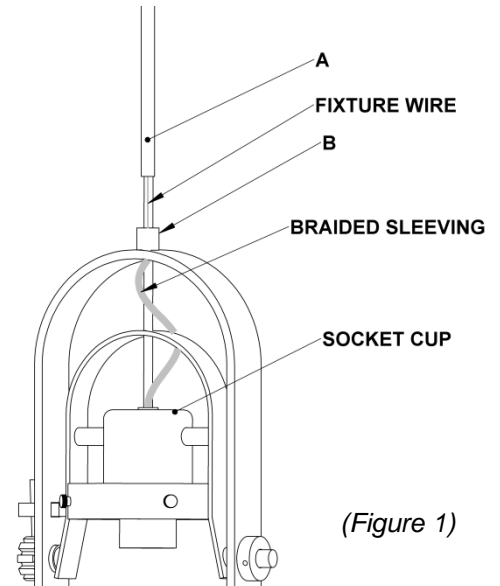

**Note:** Application of the thread locking compound is necessary to prevent the stem from loosening during regular maintenance and cleaning of the fixture. Be certain to apply the compound.

## Prepare the Canopy (Figure 2)

### Component Parts

- C Crossbar
- D Jam Nut
- E Threaded Nipple
- F Canopy
- G Canopy Ring

**Caution:** Be sure power is off at the main breaker box prior to installation.

1. Thread the jam nut (D) and crossbar (C) onto threaded nipple (E); leave both parts loose.
2. Using two machine screws (not provided), temporarily fasten the crossbar (C) to the electric box. **Note:** A new electric box comes with screws. When replacing a fixture, retain the existing screws for use with the new fixture.
3. Adjust the length of threaded nipple (E) in crossbar (C) so that canopy ring (G) will hold canopy (F) against the ceiling with no threads showing for best appearance. When the correct adjustment is established, tighten jam nut (D) against crossbar (C) to hold the adjustment.
4. Remove the crossbar (C) with stem from the electrical box and proceed with the assembly instructions.

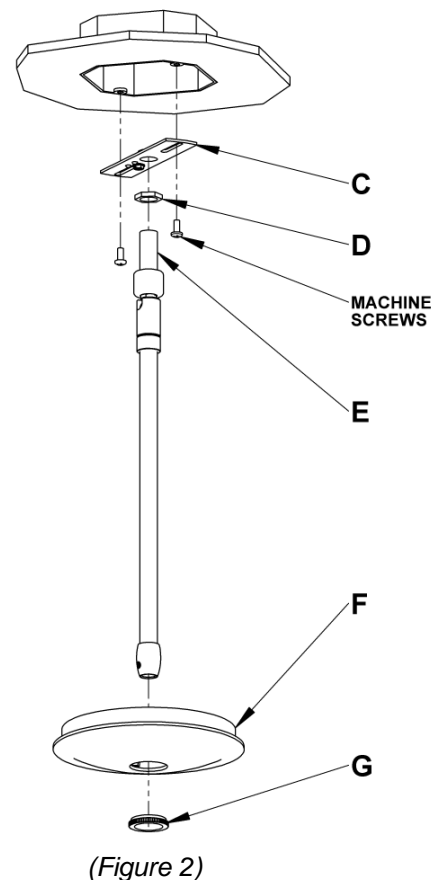

(continued)

# Assembly & Installation Instructions

Erlenmeyer Kitchen Pendant 18720

**A400**

Page 2 of 3

## Complete Assembly and Install Fixture (Figure 3 & 4)

### Component Parts

- A Fixture Pipe
- C Crossbar
- F Canopy
- G Canopy Ring
- H Canopy Pipe
- J Clutch
- K Set Screw
- L Glass
- M Ground Screw
- N Thumbscrews (4)
- O Pin
- P Strain Relief

**Caution:** Be sure power is off at the main breaker box prior to installation.

1. Carefully slide canopy ring (G) and canopy (F) down over fixture pipe (A) until they rest on the fixture. Make sure smaller diameter side of canopy ring is oriented up toward the canopy (Figure 3).
2. Slip wires from the fixture pipe (A) through the canopy pipe (H).
3. Unscrew the clutch (J) from the canopy pipe (H); slide it across the wires and onto the fixture pipe (A). Follow this with the plastic sleeve, oriented so the tapered end nests in the clutch (J) (Figure 4)
4. Slide the canopy pipe (H) on to fixture pipe (A) as far as necessary to give you the total length of the fixture which you desire. Be careful not to scratch the pipe surfaces and to pull excess wire up through the canopy pipe (H). There must be a minimum 1-1/2" of inner pipe inside the outer pipe. Hand-tighten the clutch to temporarily hold this adjustment. Tighten the set screw (K) firmly with hex wrench provided.

**Important:** To ensure full connection strength, be sure the tapered end of the plastic clutch sleeve is oriented toward the clutch when assembled and securely tighten set screw (Figure 4).

5. Using two machine screws (not provided), fasten the crossbar (C) to the electric box.  
**Note:** A new electric box comes with screws. When replacing a fixture, retain the existing screws for use with the new fixture.
6. Weave black and white wires from fixture through strain relief (P). Strain Relief can be found in the kit bag. Slide strain relief up tight to the backside of the crossbar.
7. Using suitable wire connectors (not provided), connect fixture wires to supply wires (white to white supply, black to black supply). Run a pigtail lead from crossbar ground screw (M) to the junction box and connect all ground wires (bare copper or green to bare copper or green). Push wires back into outlet box. **Caution:** Make sure wire connectors are twisted on securely, and no bare wire is exposed.

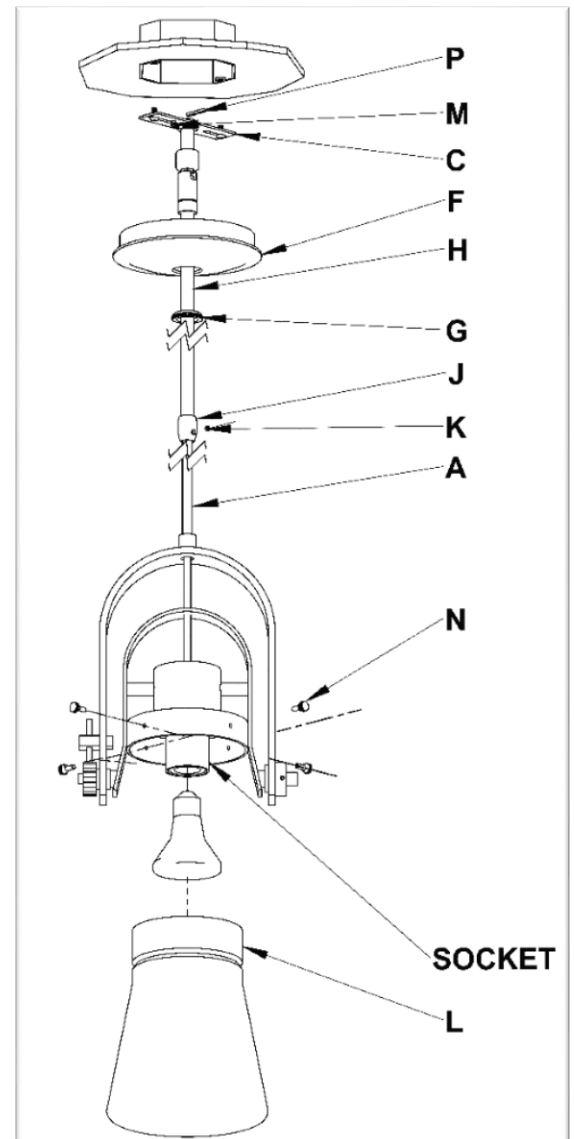

(Figure 3)

(continued)

# Installation Instructions

Erlenmeyer Kitchen Pendant 18720

**A400**

Page 3 of 3

8. Slide canopy (F) against ceiling, and secure with canopy ring (G).
9. Install bulb into socket.
10. Loosen thumbscrews (N) . It is not necessary to remove thumbscrews.
11. Slip glass (L) into ring aligning groove in glass with thumbscrews (N) and tighten thumbscrews (N).
12. Glass angle is adjustable. To rotate remove pin (O) and rotate fixture center to desired angle and insert pin thru tab and into gear. (Figure 5)
13. Restore electricity at main breaker.

**Caution:** When adjusting the angle of the fixture, be sure not to pull on the braided sleeving that covers the fixture wires. There is only approximately 12" of braided sleeving supplied with the fixture. If the braided sleeving is pulled out of the pipe it is difficult to push it back in. If the sleeving does pull out of the pipe, squeeze the end of the braided sleeving tight against the fixture wires and feed into the fixture coupling and pipe a little at a time. **When adjusting the bushing at the top of the fixture might pull up slightly. When adjustment is complete push bushing back into the hole.**

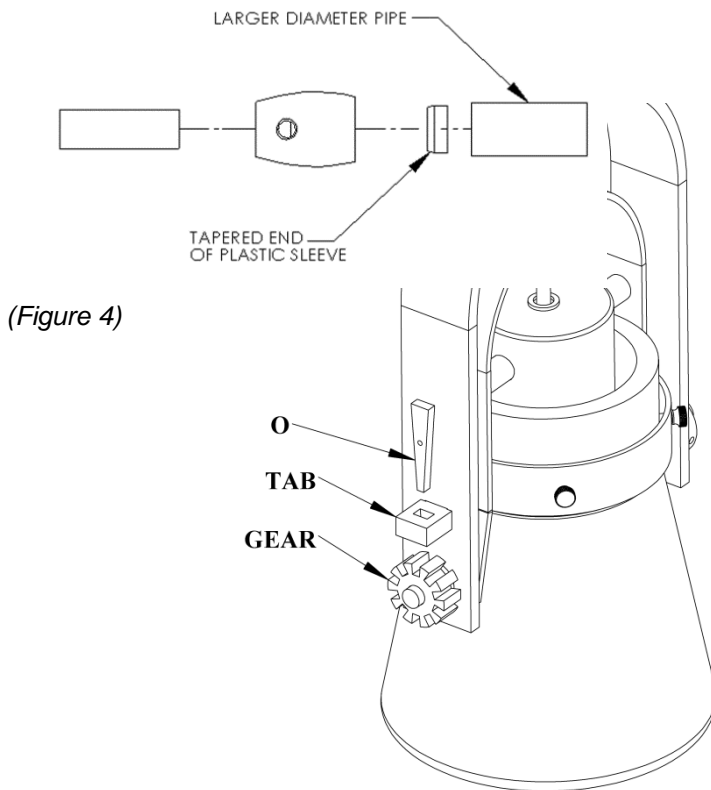

(Figure 4)

(Figure 5)

*If you need further assistance, or find that you are missing any parts, please contact the dealer from which you purchased this product. We hope you enjoy your fixture!*

\* Hubbardton Forge will not be liable for injury or damage caused by improper installation, lamping or use of this fixture.