

REGINA ANDREW

DETROIT

ITEM NO: 16-1379
French Maid Flush Mount

CAREFULLY INSPECT THE ITEM BEFORE INSTALLATION.

WE STRONGLY RECOMMEND THE ITEM BE INSTALLED BY A LICENSED ELECTRICIAN.
These instructions are provided for your safety. It is very important that they are read completely before beginning the installation of your fixture.

ASSEMBLY INSTRUCTIONS

FOR WIRING DIRECTLY INTO THE JUNCTION BOX (Figure 1)

1. Turn off the breaker to the junction box at the electrical panel.
2. Inspect all parts and inventory, making sure to check all sides of the packaging for additional parts.
3. Trim the electrical cords to length, making sure to leave an extra 6-10 inches to make all connections.
4. Attach ground wire from fixture to ground wire from junction box. Fasten wires together with wire nut and tightly wrap connection with electrical tape. Attach hot wire from fixture (black color or smooth side of wire) to hot wire from junction box. Fasten wires together with wire nut and tightly wrap connection with electrical tape. Attach neutral wire from fixture (white in color or ribbed side of wire) to neutral wire from junction box. Fasten wires together with wire nut and tightly wrap connection with electrical tape. Carefully push wire connections back into ceiling junction box.
5. Install the crossbar onto the junction box with the included machine screws.
6. Simultaneously move the canopy upward toward the junction box and secure it to the ceiling with the socket ring.
7. Assemble all additional decorative parts and bulbs.
8. Turn the breaker to the junction box back on and enjoy.

FIXTURE ASSEMBLY (Figure 2)

1. Insert appropriately rated bulb into the socket.
2. Attach diffuser to the metal shade by tightening finials.

Figure 1

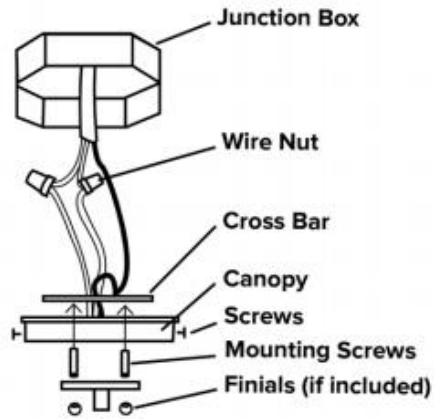
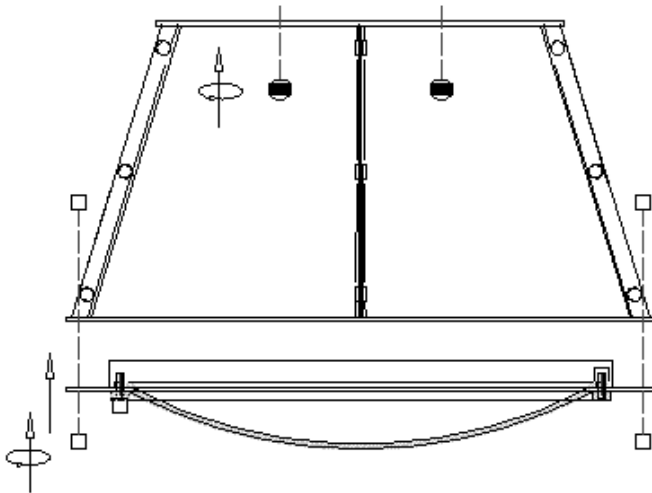

Figure 2



Made in China