

GENERAL

1. To ensure the success of the fixture installation, the following instructions and diagram(s) should be read and understood.
2. All electrical connections must be made in accordance with the National Electric code and local codes and ordinances. If you are uncertain of the methods of installing electrical wiring and lighting fixtures secure the services of a qualified licensed electrician.
3. **THIS PRODUCT MUST BE INSTALLED IN ACCORDANCE WITH THE APPLICABLE INSTALLATION CODE BY A PERSON FAMILIAR WITH THE CONSTRUCTION AND OPERATION OF THE PRODUCT AND THE HAZARDS INVOLVED**

TOOLS NEEDED

Blade screwdriver, phillips screwdriver, slip joint pliers or small adjustable wrench, wire cutter/stripper, electrical current tester, stepladder and electrical tape.

INSTALLATION PREPARATION

1. **TURN OFF THE ENTIRE ELECTRICAL CIRCUIT TO WHICH THE LIGHTING FIXTURE IS TO BE ATTACHED.** Turn circuit breaker to the "off" position or completely remove the fuse controlling the circuit.
2. If an existing fixture is being replaced, remove it and note to which of the wires in the outlet box the fixture was attached. **DO NOT SEPARATE MULTIPLE TWISTED WIRES THAT MAY BE IN THE BOX. DO NOT DAMAGE THE INSULATION OF OLDER WIRING.** In regular circumstances the BLACK wire will be the "Hot" lead and the WHITE wire will be the "Neutral" or "Common" lead. A GREEN or BARE COPPER wire is the "Ground". In older buildings it is always good practice to reconfirm the polarity of the wiring.
3. This fixture is designed to be mounted on an octagon box. The box must be securely mounted to the structure of the building.

FIXTURE INSTALLATION

1. Remove the fixture and parts bag(s) from the carton. Before discarding the carton, double check packing to make certain that all parts are found.
2. Attach the mounting plate to the outlet box. (The green screw should face out). Pull wires out of box.
3. Fasten the bare ground wire to the green or bare copper wire in the outlet box or the green screw on the crossbar.
NEVER FASTEN THE GROUND WIRE TO THE BLACK OR "HOT" WIRE ! FAILURE TO FOLLOW THIS INSTRUCTION COULD RESULT IN SERIOUS INJURY OR DEATH !
4. Fasten the driver input wire (white) to the white wire in the outlet box. Fasten the wires together with an approved fastener (wire nut) Starting about 1" below the fastener, tightly wrap the connection with electrical tape so that the tape seals the end of the fastener. **Make sure that there is no exposed wire or strands that could cause a dangerous short circuit !**
5. Connect the driver input wire (black) to the black wire in the outlet box. Fasten the joined wires as in step 4.
6. Mount the canopy to the mounting plate and secure with set screws.
7. Install the LED bulbs onto the fixture.
8. Restore power to circuit at breaker or fuse box.

DIMMING

The fixture can be controlled by a wall dimming device. Only use Triac/electronic dimmer. Make sure the carton is marked for use with LED compact fluorescent-incandescent light source only. These can be provided by your local electrical distributor, home center, or hardware store.

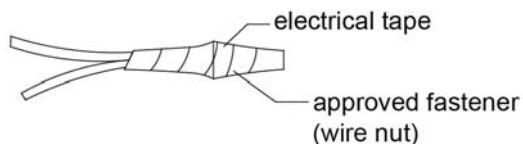
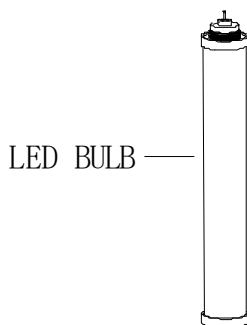
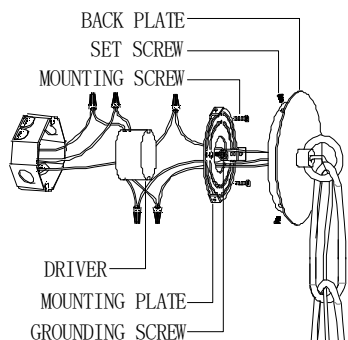

Thank you for purchasing our lighting fixture.

Please clean with a soft, dry cloth ONLY! Do not use cleansers.

www.hudsonvalleylighting.com/mitzi