



1718 W. Fullerton Chicago, IL 60614
 Ph: 773.770.1195 • Fax: 773.935.5613
 www.PureEdgeLighting.com • info@PureEdgeLighting.com
 © 2016 PureEdge Lighting. All Rights Reserved.

Installation Instructions for **Reveal Wall Wash 2**

RVWW2-__-__

IMPORTANT INFORMATION

- This instruction shows a typical installation.
- Reveal Wall Wash must be mounted 24" away from the wall.
- It is recommended that a qualified electrician install this product.



SAVE THESE INSTRUCTIONS!

Section One: Install the Junction Box

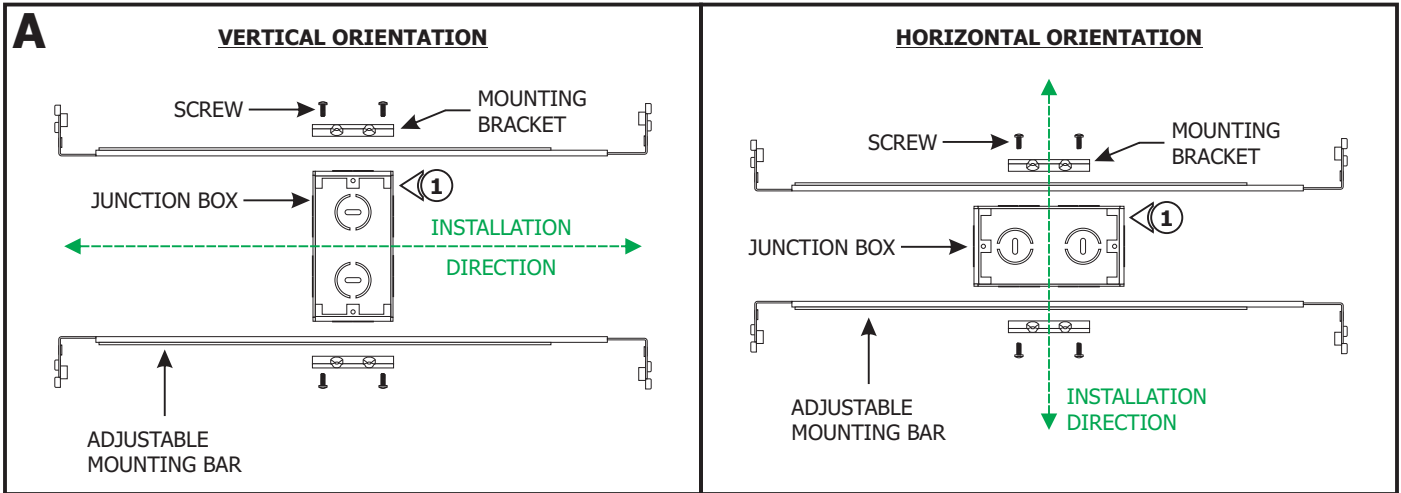

NOTE: Before beginning any electrical work, ensure that power to the electrical box is turned off.

- 1:** Mount each adjustable mounting bar to one side of the junction box (mounts to any side of the housing depending on the orientation of the channel) and secure them with the mounting brackets and two Phillips screws provided.

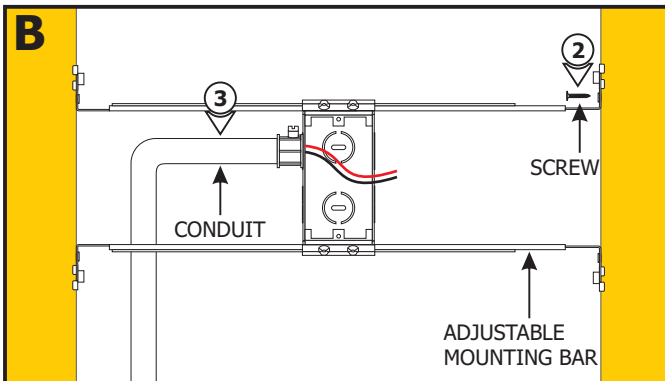

NOTE: The adjustable mounting bars mount to studs that are spaced 15"-24" apart. If the span needs to be shorter than 15", then break the bar arms from dedicated lines.

- 2:** Place the adjustable mounting bar tabs against the ceiling joists. Secure the adjustable bars to the joists with screws.
- 3:** Install conduits (if required by local electrical code) and run the low voltage 24VDC wires coming from the remote power supply to the junction box.

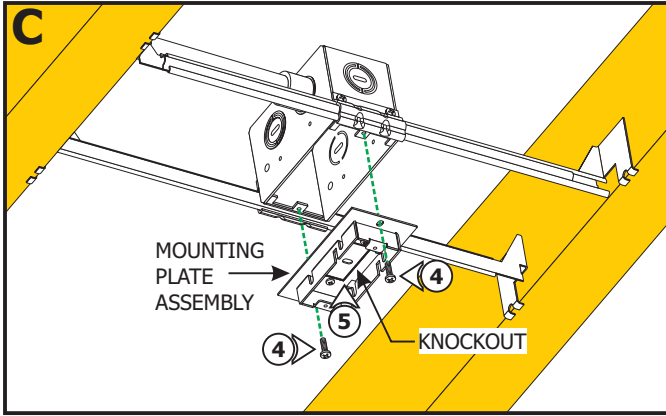

- 4:** Place the mounting plate assembly over the junction box and secure with the two screws provided.
- 5:** Remove the knockout on the mounting plate using a flathead screw driver or other appropriate tool.

- 6:** Cut a section of drywall using a 6" fixed jab saw or other appropriate tool to expose the junction box cover area. Install the drywall.

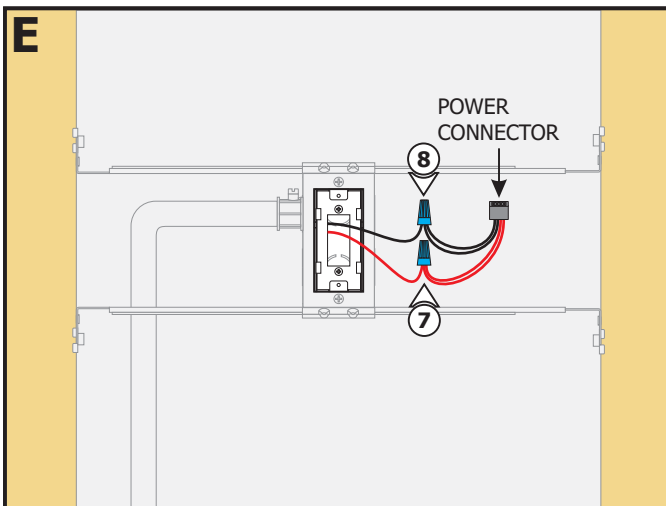
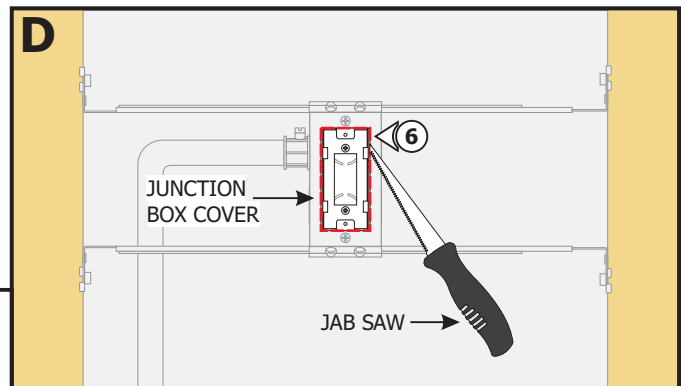

NOTE: Remote power supply wires must be present in the junction box. Refer to the instructions provided with power supply.

- 7:** Connect the +24VDC low voltage power supply wire to the red wires of the power connector using a wire nut.
- 8:** Connect the -24VDC low voltage power supply wire to the black wires of the power connector using a wire nut.
- 9:** Place all wire nut connections inside the junction box.

CAUTION: Unroll the entire LED strip from the reel and use the power connector to power the strip making sure there is no outage before continuing with the installation. Afterwards, carefully roll the LED strip loosely back into the reel.

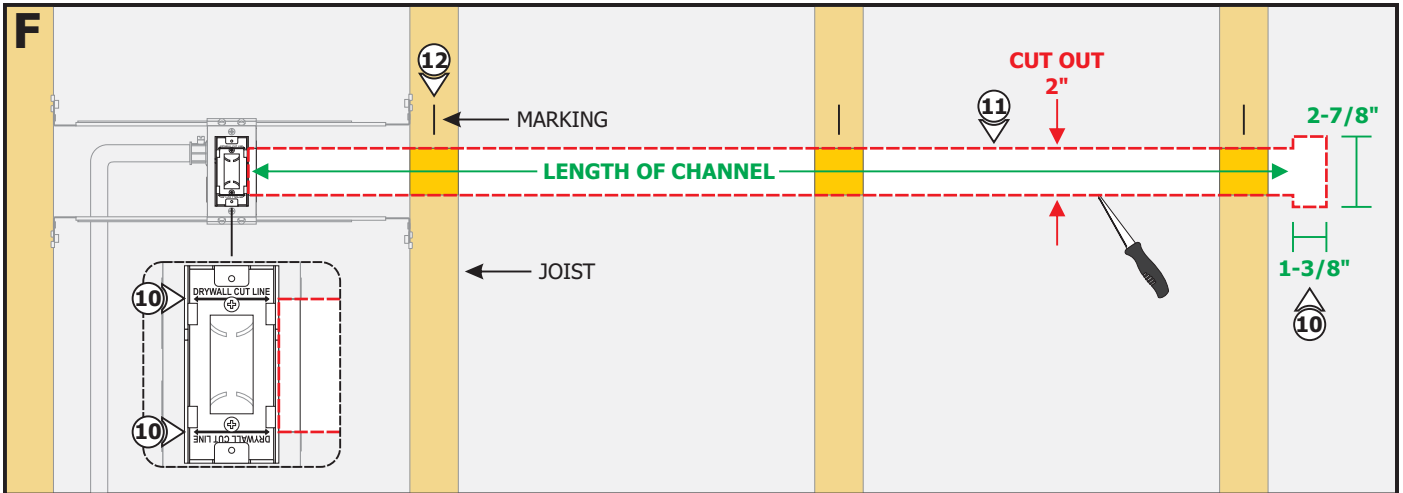

10: Mark the area where the installation will be located on the ceiling using the Drywall Cut Lines on the mounting plate as a guide (**MIN 2"**). If necessary, allow for **MIN 1-3/8" x 2-7/8"** extra space at the end of the installation for the optional Take-Up Box. The Take-Up Box is used when there is excess LED strip (less than the cuttable section) is exposed behind the channel.

11: Cut out the marked area on the drywall using a jab saw or other appropriate tool.

12: Mark the location of the ceiling joists to the drywall for future reference.

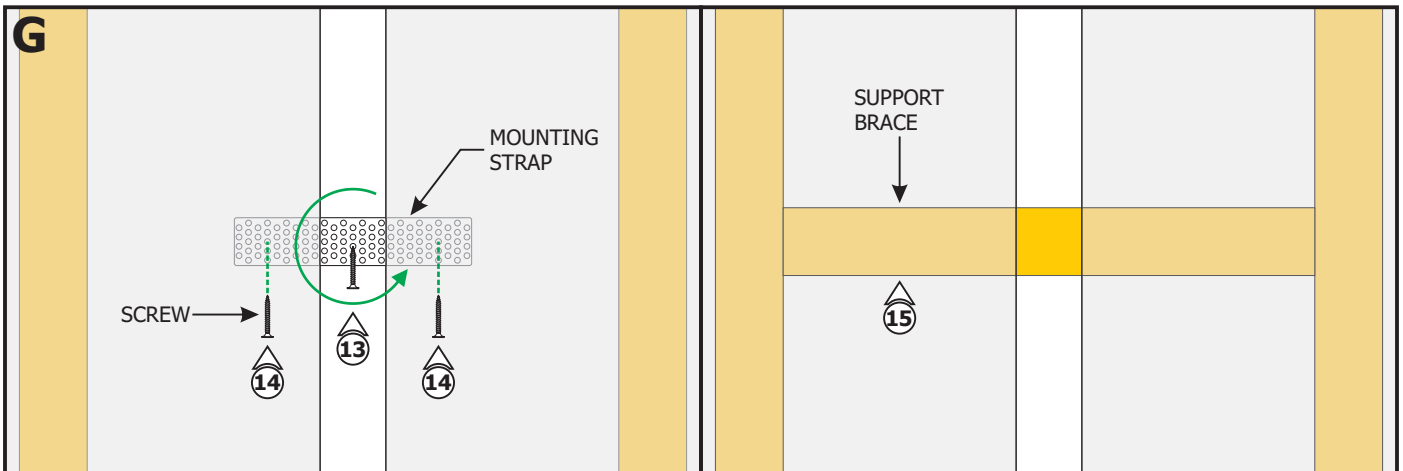

NOTE: To install the channel in a wall without standard-spaced studs, install perforated mounting straps every 32" behind the drywall.

NOTE: For areas with lots of vibrations, it is suggested to install 2x4 support braces (suggested spacing is every 32") before installing and finishing drywall to avoid cracking of plaster. Refer to step 15.

13: Thread a drywall screw into the perforated material. Place the mounting strap behind the drywall and rotate into place using the drywall screw.

14: Secure the mounting strap to the drywall using two drywall screws. Mark the location of the mounting strap on the drywall.

Alternate Installation Option:

15: Install 2x4 support braces (suggested spacing is every 32") before installing and finishing drywall.

Section Two: Install the Channel

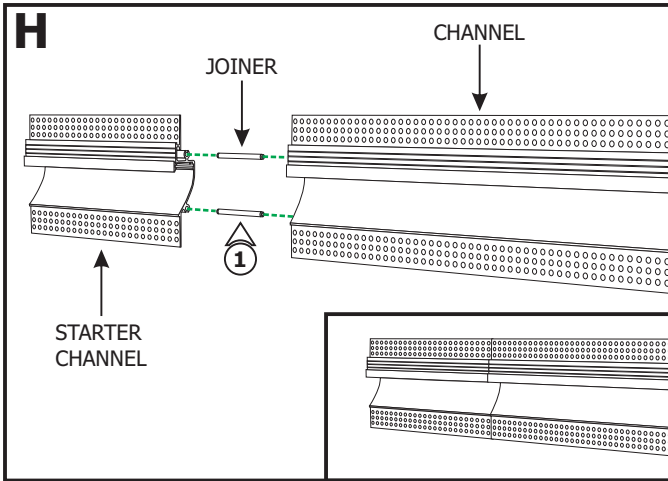

1: Insert the channel joiners half way into the 6" starter channel and then slide the channel over the joiners.

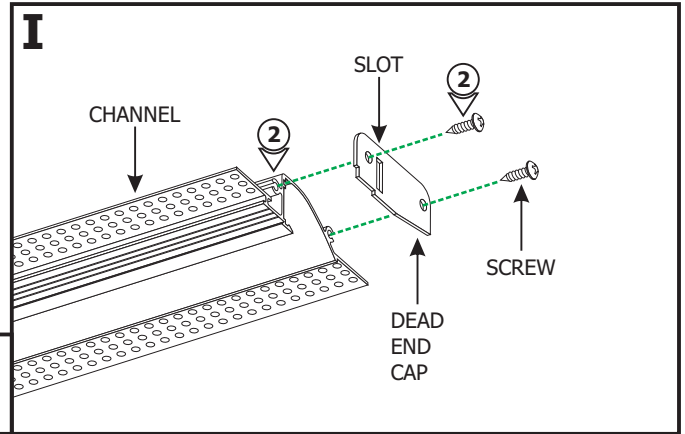

2: Align the dead end cap slot with the LED section at the end of the channel. Attach the dead end cap to the end of the channel using the two screws provided.

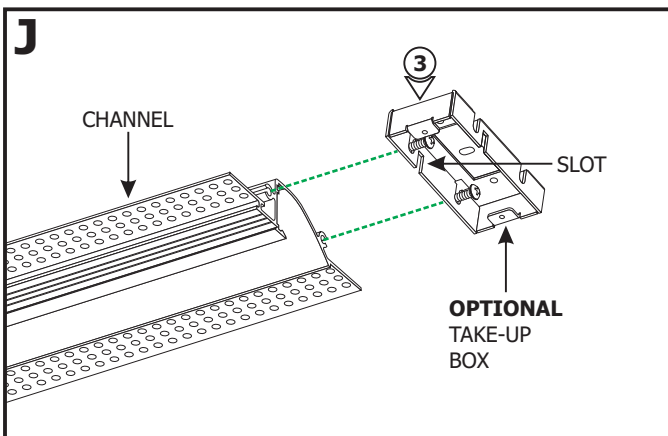

Optional Take-Up Box:

3: Align the LED section of the channel with the slot of the other junction box cover. Attach the assembled channel to the junction box cover using the two screws.

4: Discard the dead end cap.

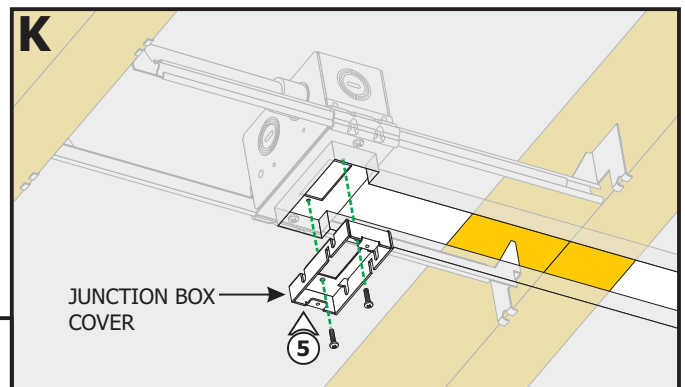

5: Remove the junction box cover from the mounting plate by removing the two screws.

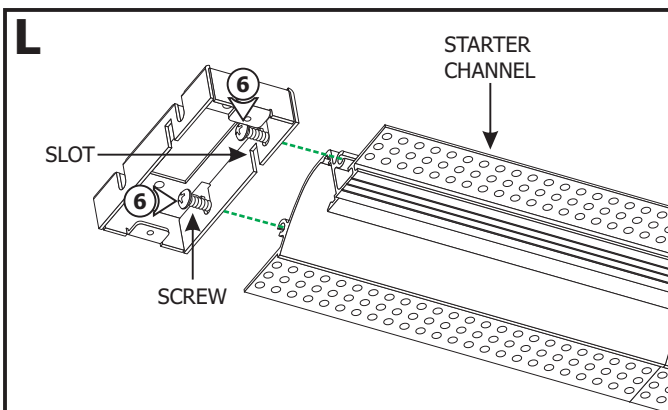

6: Align the LED section of the channel with the junction box cover slot. Attach the assembled channel to the junction box cover using the two screws.

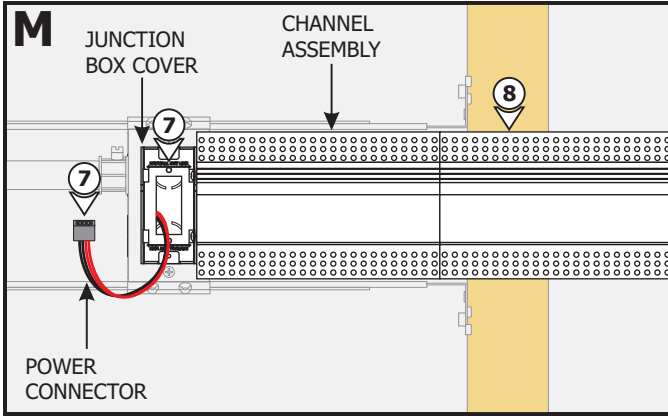

7: Feed the power connector through the junction box cover. Align the junction box cover with the mounting plate holes and push the assembled channel into the cutout area.

8: Make sure the channel is aligned straight using a level.

9: Place the power connector into the LED slot of the junction box cover.

10: Install the power connector holder inside the junction box cover and secure to the mounting plate using the two screws.

NOTE: Note the alignment of the red +24VDC connection of the power connector to ensure proper alignment when installing the LED strip in later steps.

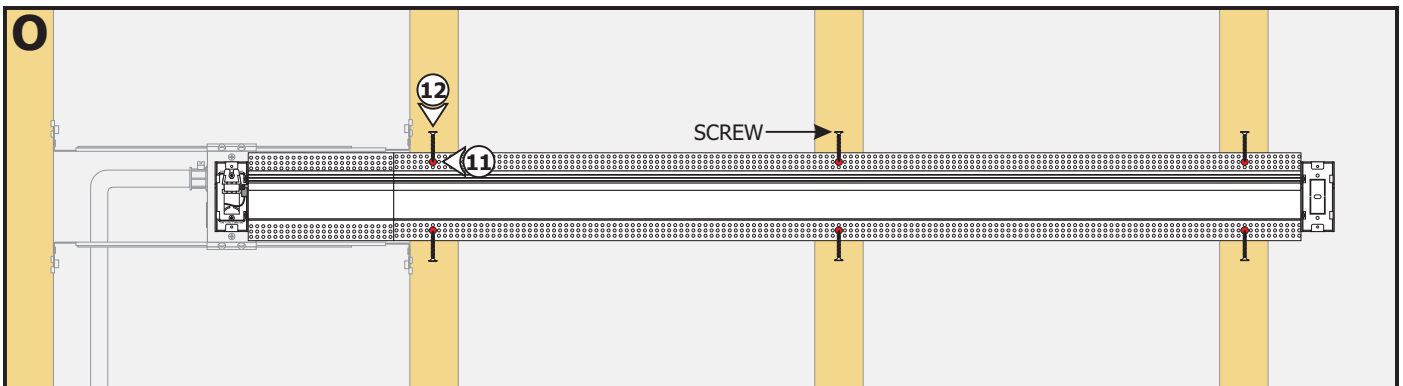
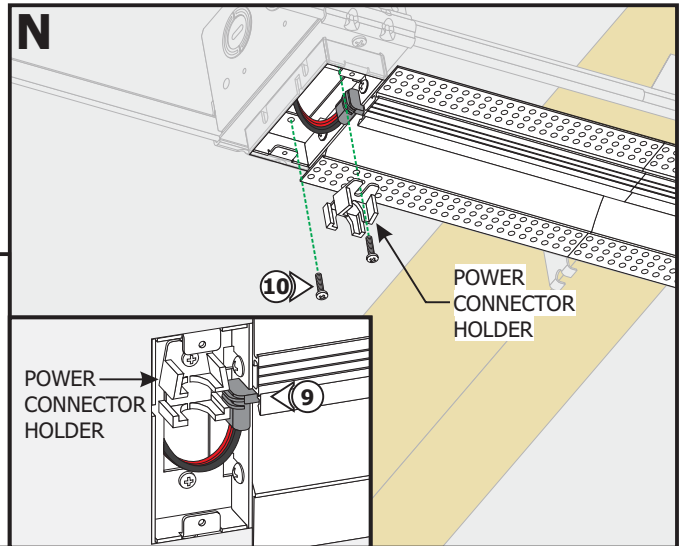

11: Drill and countersink holes to the channel at marked joist locations.

12: Secure the channel to the joists using drywall screws.

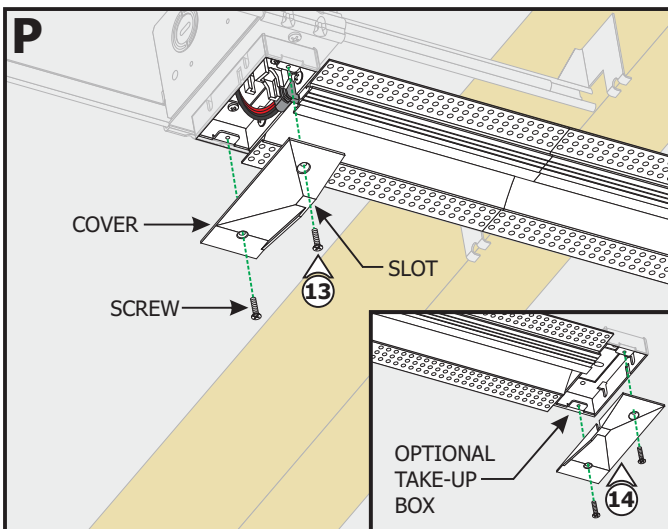

13: Align the wall wash cover slot with the LED section of the channel and secure the wall wash cover to the junction box cover using two screws.

14: Repeat step 13 if using the optional Take-Up Box.

Section Three: Tape and Plaster

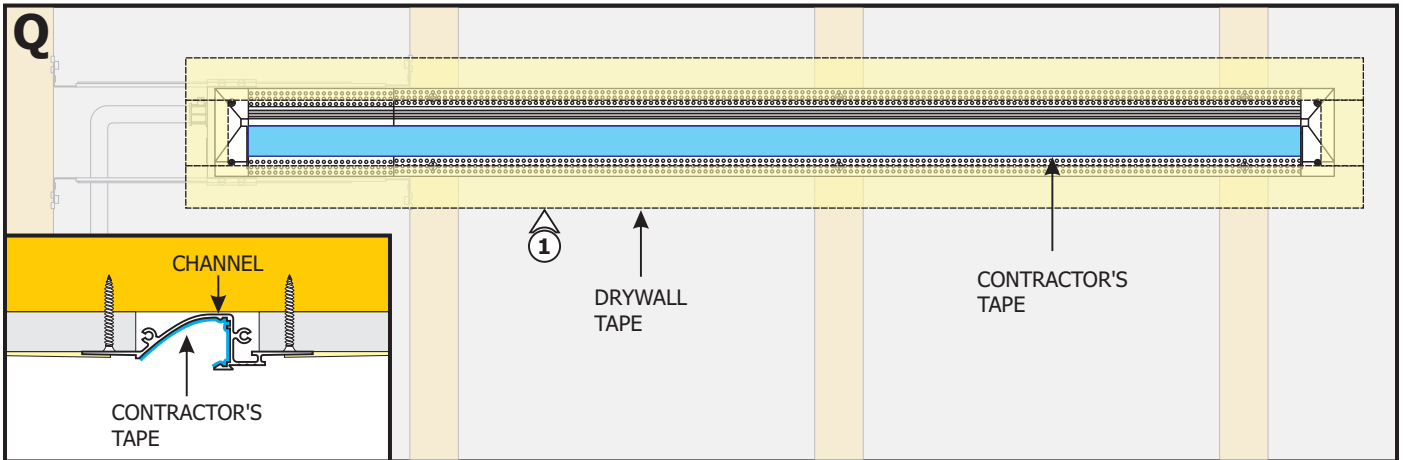

NOTE: Cover the channel opening with blue contractor's tape before plastering.

NOTE: For areas with lots of vibration, it is suggested to use Durabond to avoid cracking of plaster.

NOTE: Do Not use premixed joint compound "Soft Mud." No use compuesto para juntas premezclado "Soft Mud."

1: Must apply drywall tape (Ultra-Thin drywall tape suggested) along edges of the channel to prevent cracking of the plaster after installation. **DO NOT** overlap strips of drywall tape.

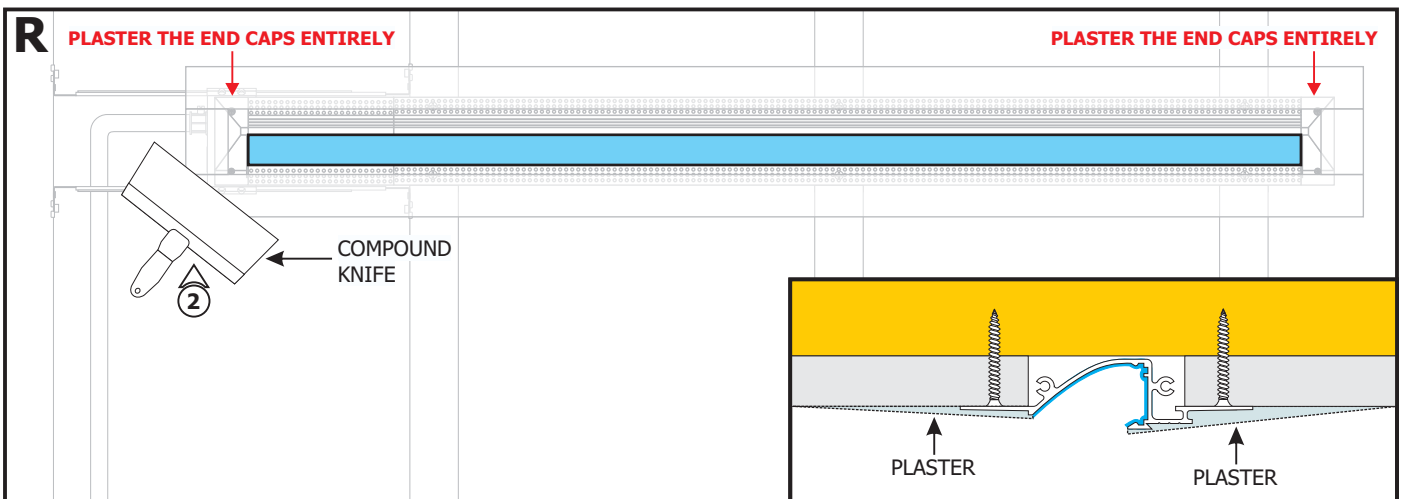

NOTE: Recommended plaster method: 1st Coat - Durabond 45 with 8" Blade, 2nd Coat - Easy Sand 45 with 10" Blade, 3rd Coat - with 12" Blade. Taper the plaster to blend with the ceiling.

2: Use a compound knife for smooth compound spread. Sand, paint and finish the plaster and drywall before removing the contractor's tape.

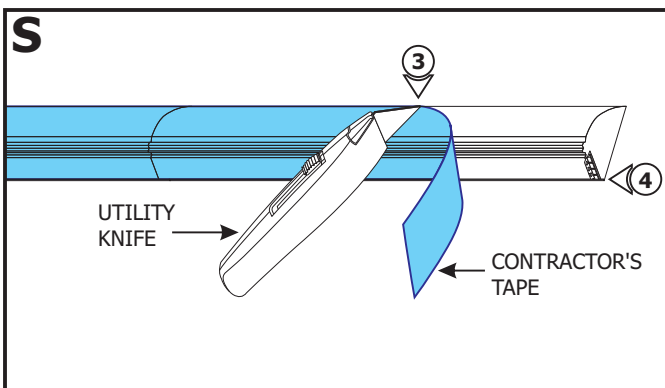

3: Use a utility knife to cut along the channel edge while removing the contractor's tape from the channel. This will avoid plaster and paint damage during tape removal.

4: Run the utility knife along the channel edge near the area where the LED Soft Strip will be installed to remove any excess paint.

Section Four: Install the LED Soft Strip

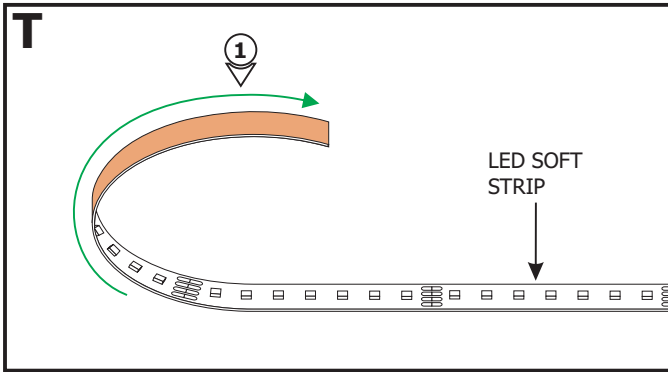

1: Gently uncoil the LED Soft Strip before applying to the channel surface otherwise the strip may lift off of the surface.

NOTE: Clean the channel area where the LED Soft Strip will be installed with alcohol to remove any dust or debris before continuing.

2: Carefully remove the backing from the LED Soft Strip, making sure not to remove the tape from the LED Soft Strip. Line up the red wire side of the power connector with the "+24VDC" marking on the LED Soft Strip. Push the male connector of the strip into the power connector.

3: Firmly press down the adhesive portion of the LED Soft Strip onto the channel surface while removing the rest of the backing, making sure there are no air bubbles that can cause surface irregularities.

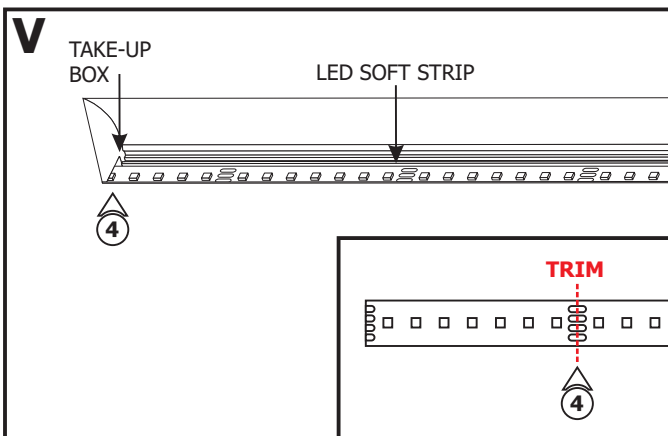
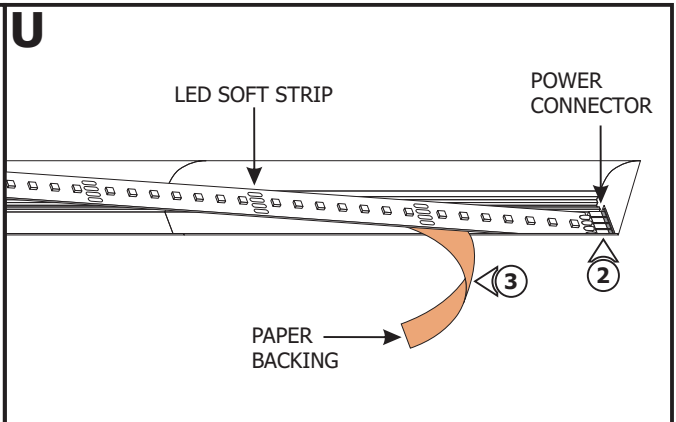

4: If required, trim the LED Soft Strip on the dashed cuttable section and place the excess LED Soft Strip inside the Take-Up Box. Ensure the entire length of the channel is covered with LED Soft Strips to avoid unlit areas.

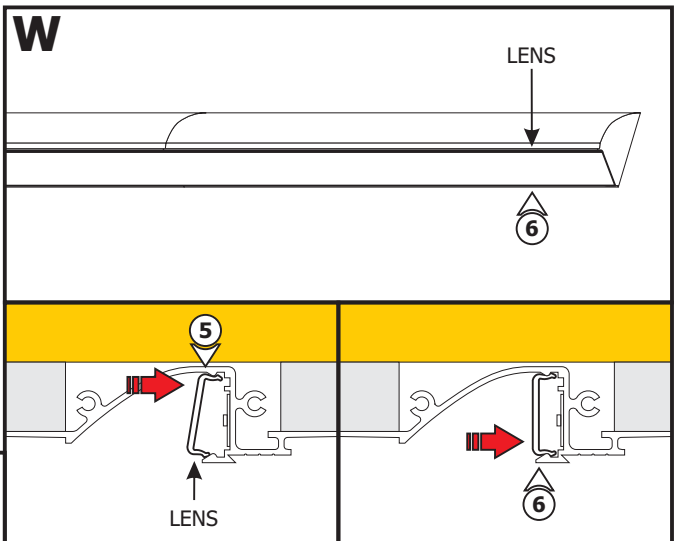

5: Push the top part of the lens into the channel first.

6: Snap the rest of the lens into the channel.

IMPORTANT INFORMATION REGARDING INSTALLATION AND REWORK OF SOFT STRIP LED

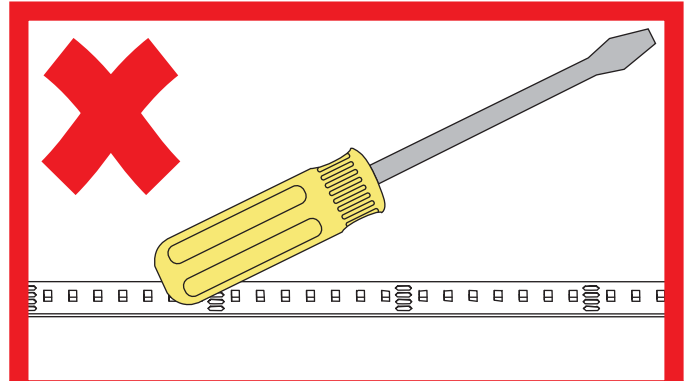
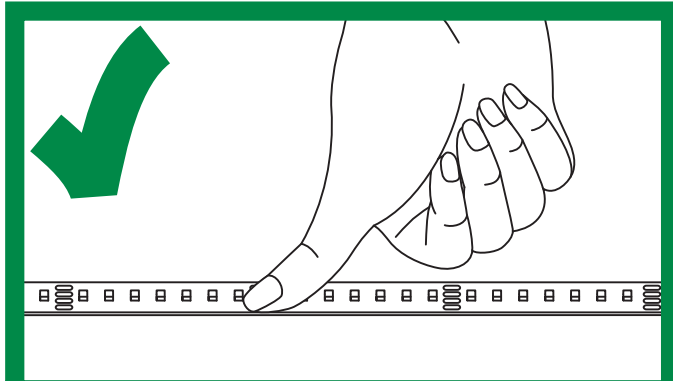
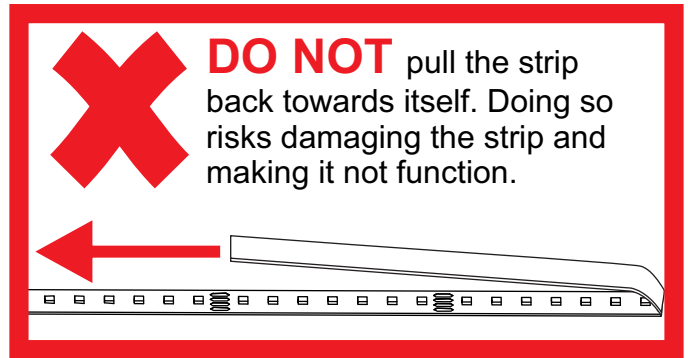
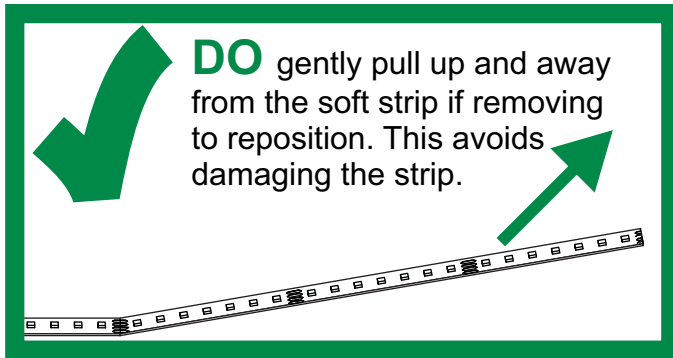

Relocating Soft Strip (Optional)

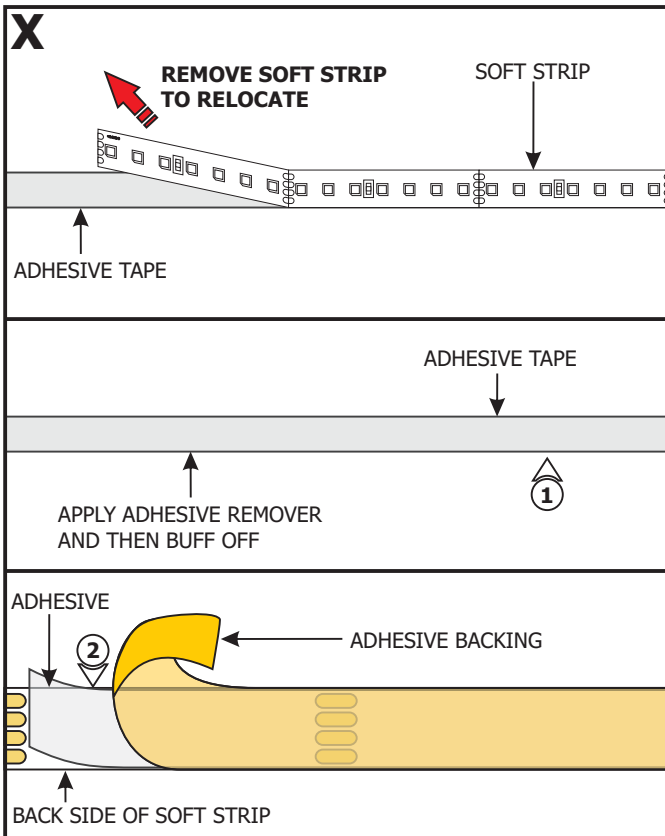

NOTE: If relocating the installed soft strip, make sure that the adhesive tape on back of the soft strip covers the entire strip. The adhesive tape isolates the strip from the installation surface. Damaged or inconsistent adhesive tape may cause the contacts on the back of the strip to come in contact with the conductive heat sink which will cause the strip to short and burn. Call PureEdge Lighting to get replacement adhesive tape and/or optional aluminum heat sink tape (SS-HR-F).

- 1:** To remove tape residue from back of the strip, apply WD-40, Goo Gone, or a mixture of warm water and lemon oil to the corner of a clean, dry towel. Gently buff the area containing the adhesive residue until it is completely removed.
- 2:** Gently remove a few inches from one side of the tape backing. Attach the adhesive tape to the back of the soft strip and apply moderate pressure to affix the tape. Continue this step a few inches at a time until the entire adhesive tape is attached to the back of the soft strip.
- 3:** Refer to Section Four to reinstall the LED Soft Strip.

General Wiring Diagrams

