



1718 W. Fullerton Chicago, IL 60614
 Ph: 773.770.1195 • Fax: 773.935.5613
 www.PureEdgeLighting.com • info@PureEdgeLighting.com
 © 2016 PureEdge Lighting. All Rights Reserved.

Installation Instructions for TruLine 1.6A Center Feed Power Channel Connector

TL.1.6A-CFP_

IMPORTANT INFORMATION

- This instruction must be used concurrently with other TruLine 1.6A BIY installation instructions.
- This product is wall or ceiling mount.
- This instruction shows a typical installation.

SAVE THESE INSTRUCTIONS!



Section One: Install the Junction Box

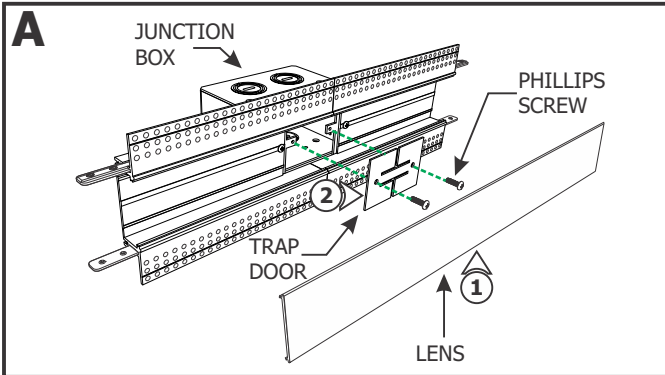

- 1: Remove the lens from the Center Feed Power Connector.
- 2: Remove the two Phillips screws from the junction box to remove the trap door from the assembly.

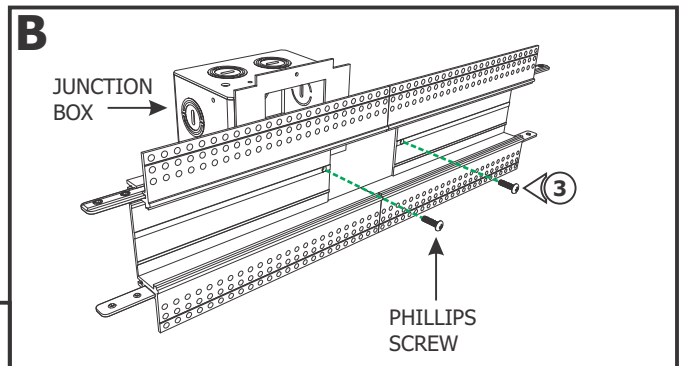

- 3: Remove the two Phillips screws from the junction box to remove the Center Feed Power Connector assembly.

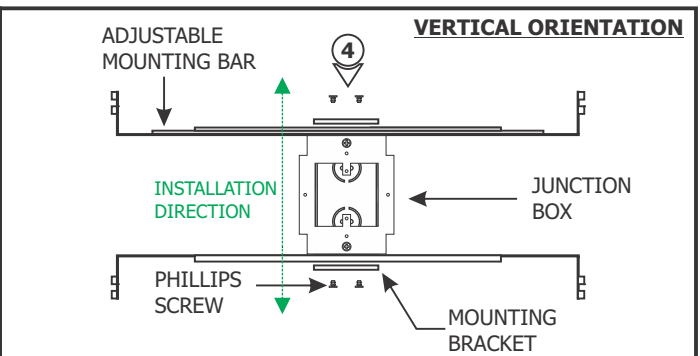
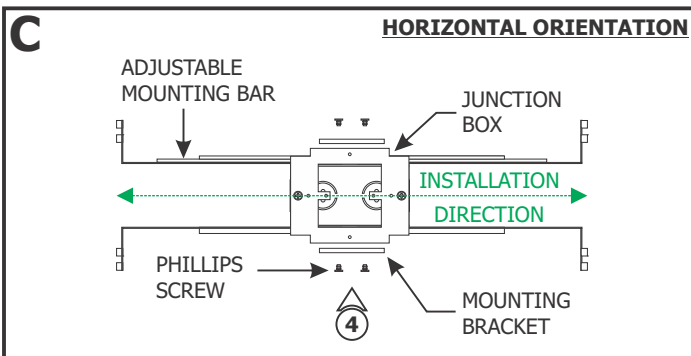

- 4: Mount each adjustable mounting bar to one side of the junction box and secure them with the mounting brackets and two Phillips screws provided.

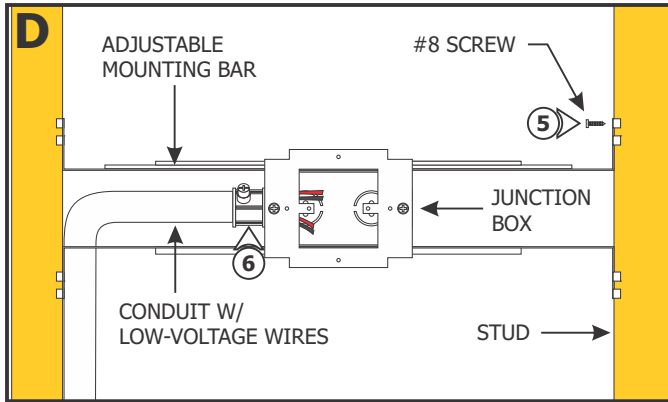

NOTE: The adjustable mounting bars mount to studs that are spaced 15" to 24" apart. If the span needs to be shorter than 15", then break the bar arms from dedicated lines.

5: Place the lips on the adjustable mounting bars against the studs. Secure the adjustable bars to the studs with the #8 screws.

6: Install conduit(s) (if required by local electrical code) and run 24VDC low voltage wires from the power supply or DMX controller to the junction box. Refer to the instructions provided with the power supply.

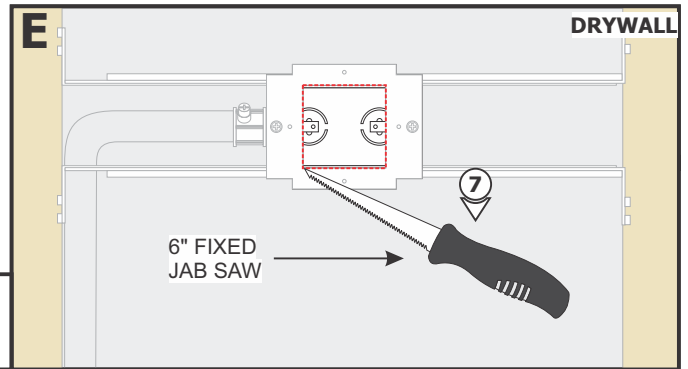

7: Cut a section of drywall using a 6" fixed jab saw or other appropriate tool to expose the mounting plate area. Install the drywall.

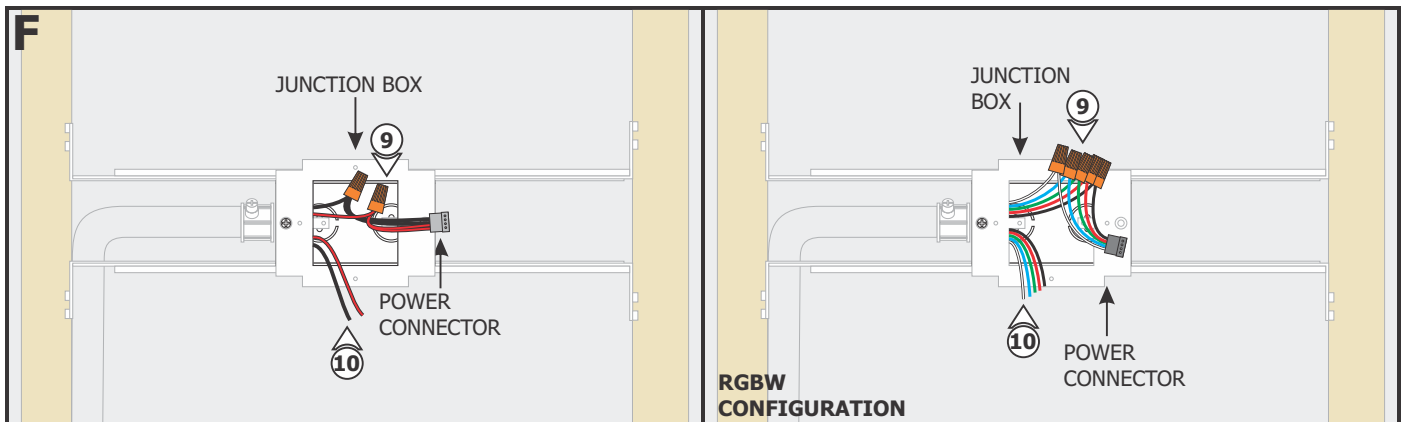

NOTE: Remote power supply wires must be present in junction box. Refer to instructions provided with power supply.

NOTE: Center Feed Power Channel could feed the strips one or both directions. When using to feed one direction, discard the other connectors.

8a: Connect the red low voltage wire of the power supply to the red wires of the power connector with a wire nut. Connect the black low voltage wires of the power supply to the black wires of the power connector with a wire nut.

8b: For RGBW Configurations, connect the black, red, green, blue and white wires of the DMX controller respectively to the black, red, green, blue, and white wires of the power connector with wire nuts.

9: Repeat step 8 for additional power connectors and power supplies.

10: Place all wire nut connections inside the junction box.

CAUTION: Unroll the entire LED strip from the reel. Use the power connectors to power the strip making sure there is no outage before continuing with the installation (refer to Sections Three or Four for proper connections). Afterwards, carefully roll the LED strip loosely back into the reel.

Section Two: Prepare and Install the Center Feed Power Connector

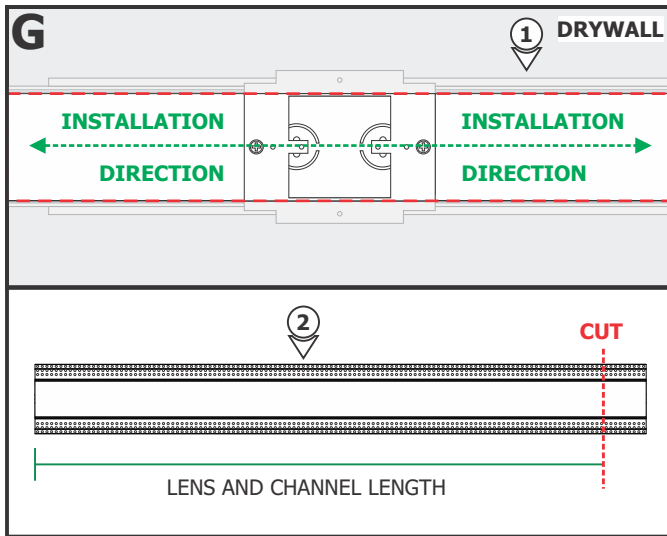

- 1: Mark and cut out the area where the installation will be located using the junction box opening as a guide (MIN 2.25").
- 2: Refer to Section One in the TruLine 1.6A Channel and Lens instructions to measure and cut the channel and lens before continuing.

- 3: Slide a channel onto the joiner bars and tighten the remaining M3 set screws with a 1.5mm Allen wrench.
- 4: Repeat step 3 for the other end of the Center Feed Power Channel Connector.

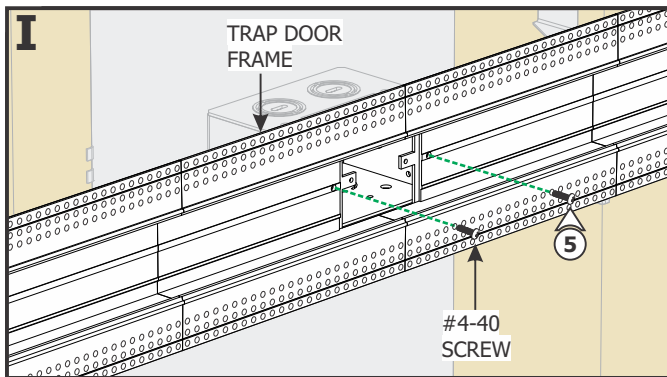
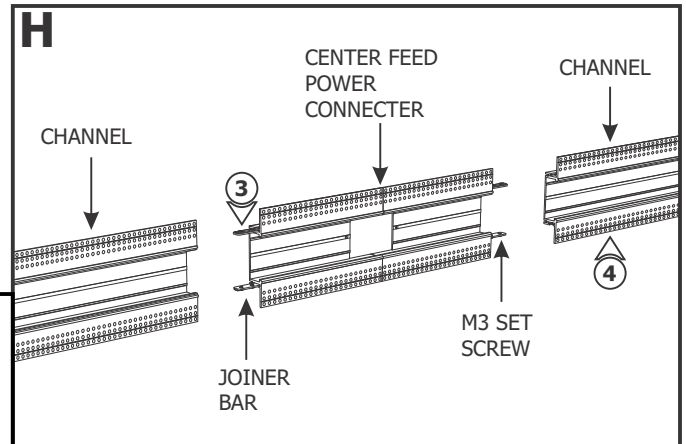

- 5: Attach the assembled trap door frame to the junction box using the #4-40 screws.

NOTE: Refer to Section Three in the TruLine 1.6A Channel and Lens instructions to plaster before continuing.

Section Three: Install the LED Soft Strip (side mount)

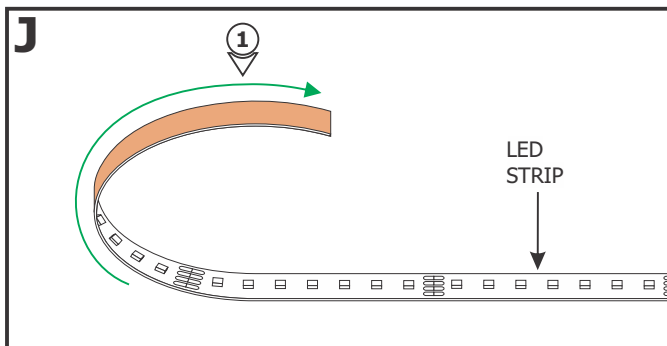

- 1: Gently uncoil the LED soft strip before applying to the channel otherwise the strip may lift off of the surface.

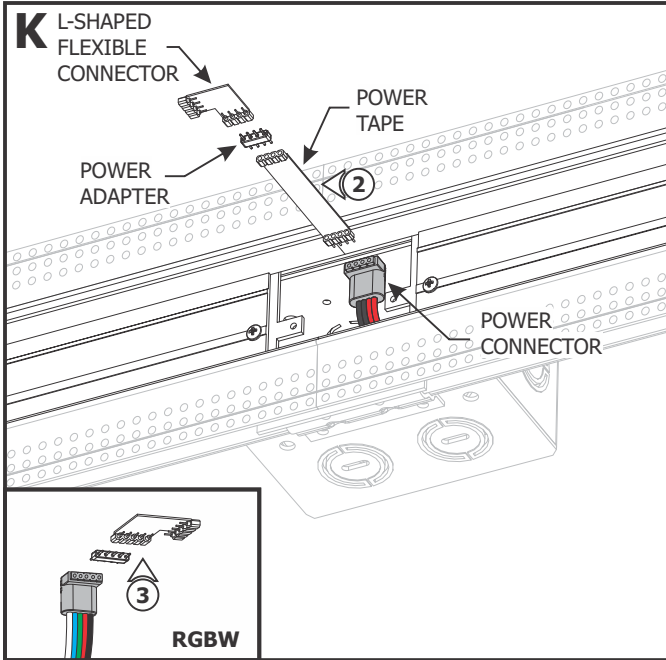

NOTE: Center Feed Power Channel could feed the strips one or both directions. When using to feed one direction, discard the other connectors.

NOTE: Omit step 2 for RGBW Configurations. Blank Soft Strip Power Tape is not used.

- 2:** Connect the Blank Soft Strip Power Tape into the power connector.
- 3:** Insert the Power Adapter and then connect the L-Shaped Flexible Power Connector to the Power Adapter.
- 4:** If necessary, repeat steps 2 and 3 for additional power connectors.
- 5:** Place the power connector and Power Tape inside the junction box.

- 6:** Place each assembled power connection into the channel where the LED Soft Strip will be installed.
- 7:** Replace the trap doors and secure using the #4-40 screws.

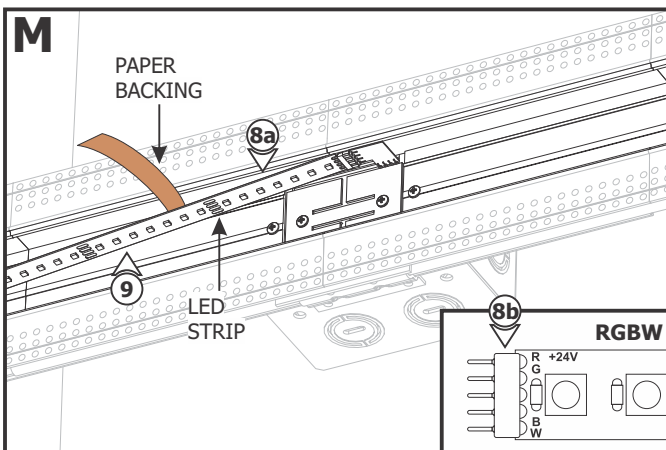
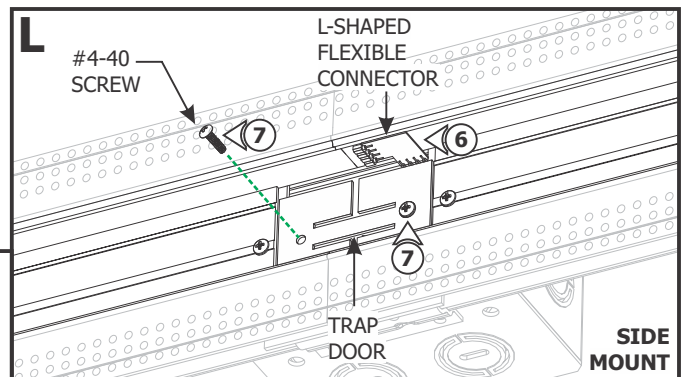

8a: Carefully remove the backing from the LED Soft Strip, making sure not to remove the tape. Line up the red wire side of the power connector with the "+24VDC" marking on the LED Soft Strip. Push the male connector of the LED Soft Strip into the L-Shaped Flexible Power Connector.

8b: For RGBW Configurations, align the RGBW markings on the LED Soft Strip with the corresponding wires of the power connector. Push the male connector of the strip into the power connector.

9: Firmly press down the adhesive portion of the LED Soft Strip onto the side mount channel surface while removing the rest of the backing, making sure there are no air bubbles that can cause surface irregularities.

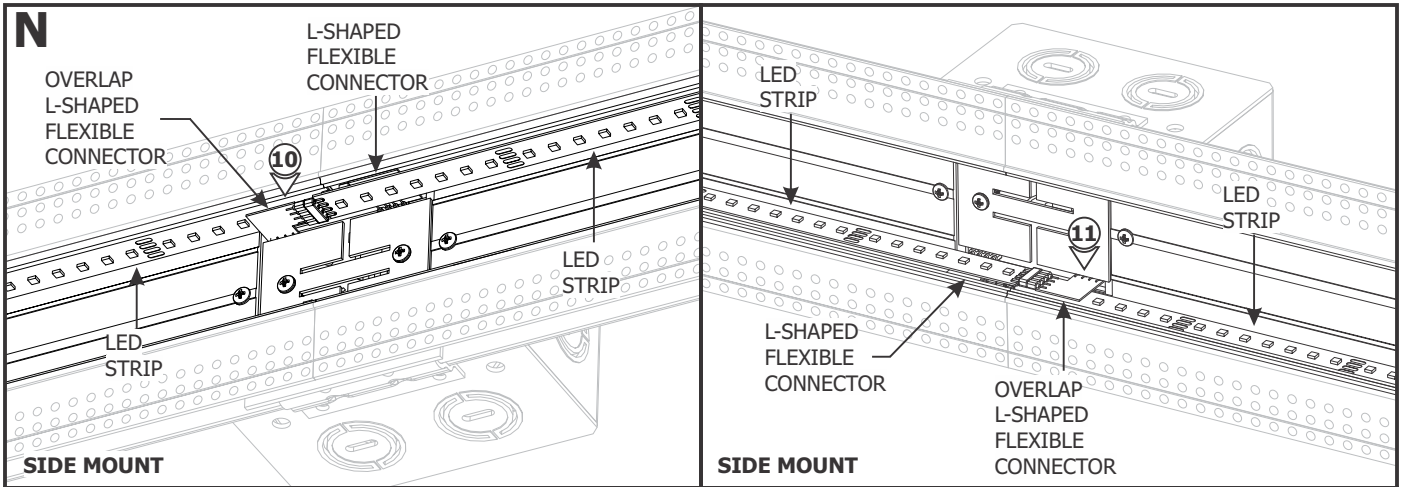

10: On the same side of the channel, the second Flexible Connector should overlap the first LED strip and Flexible Connector.

11: Repeat steps 8 through 10 for the other LED strips on the other side of the channel. Ensure that the overlapped Flexible Connectors on both sides of the channel are on opposite corners from each other to avoid dark spots.

Section Four: Install the LED Soft Strip (bottom mount)

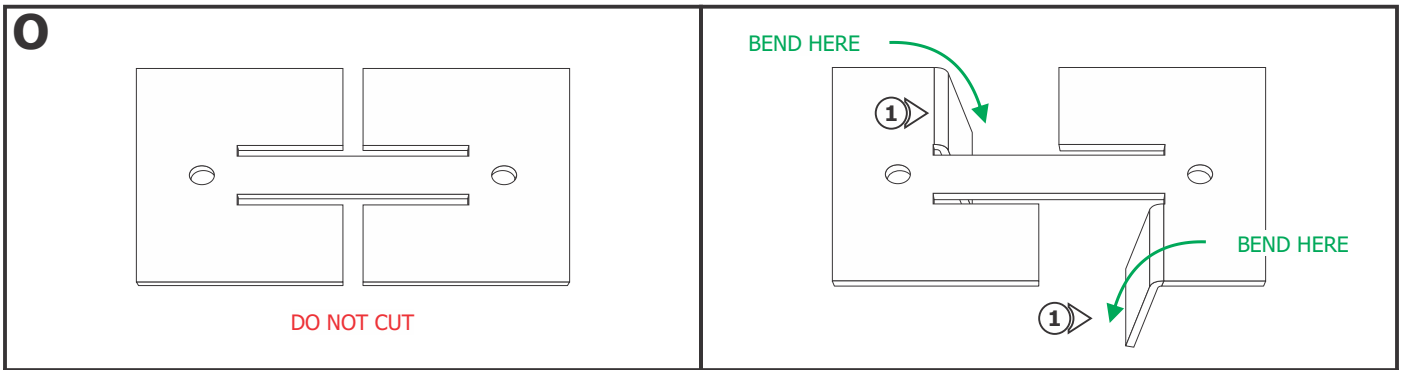

NOTE: Do not cut the trap door.

1: Use pliers to bend the large section of the trap door cover to allow for access to power connections.

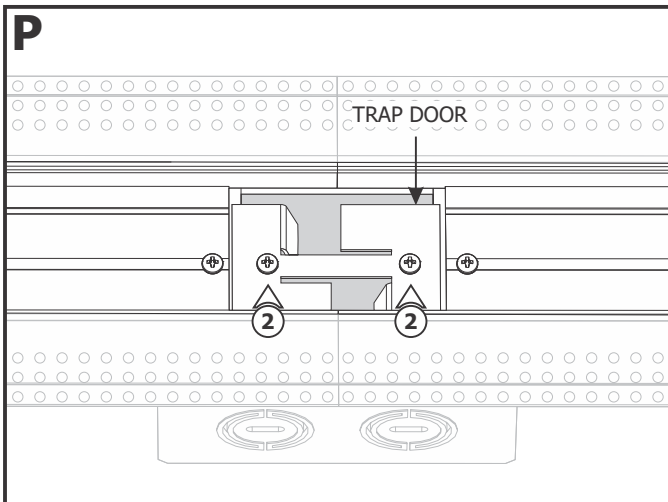

NOTE: This product can be used as a combination of side and bottom mount.

2: Attach the bent trap doors to the Center Feed Power Connector with the two provided screws.

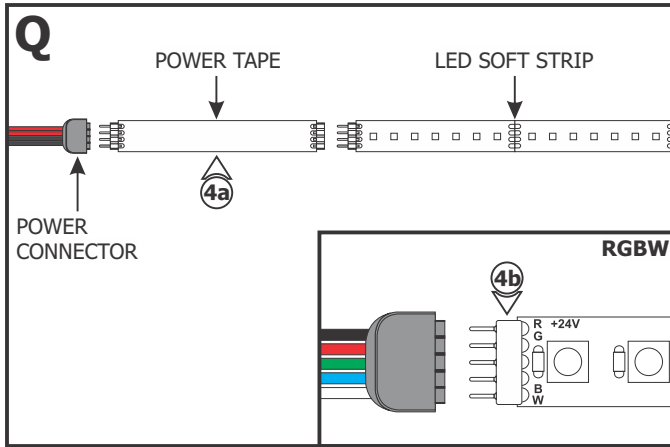

3: Refer to step 1 in Section Three to uncoil the LED Soft Strip.

4a: Connect the Blank Soft Strip Power Tape to the power connector. Line up the red wire side of the power connector with the "+24VDC" marking on the LED Soft Strip. Push the pins of the LED Soft Strip into the power connector.

NOTE: RGBW Configurations, Blank Soft Strip Power Tape is not used.

4b: For RGBW Configurations, align the "RGBW" markings on the LED Soft Strip with the corresponding wires of the power connector. Push the pins of the LED Soft Strip into the power connector.

5: If necessary, repeat step 4 for additional power connectors.

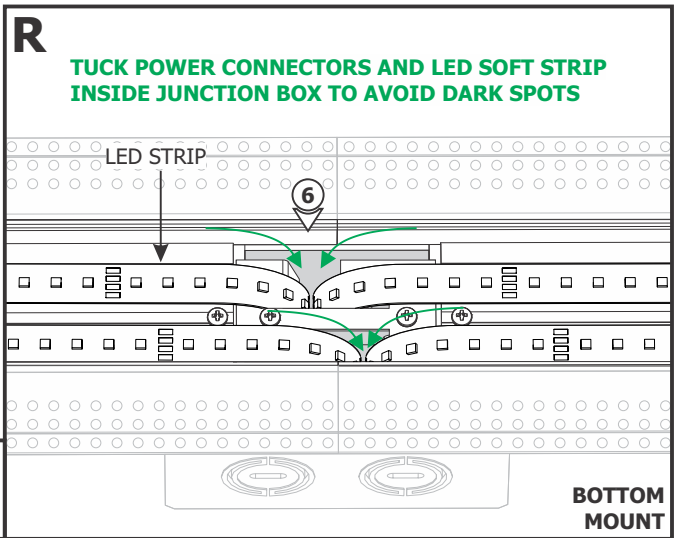

6: To avoid any dark spots, feed the power connector and power tape inside the junction box. If necessary, tuck the LED Soft Strip slightly inside the junction box.

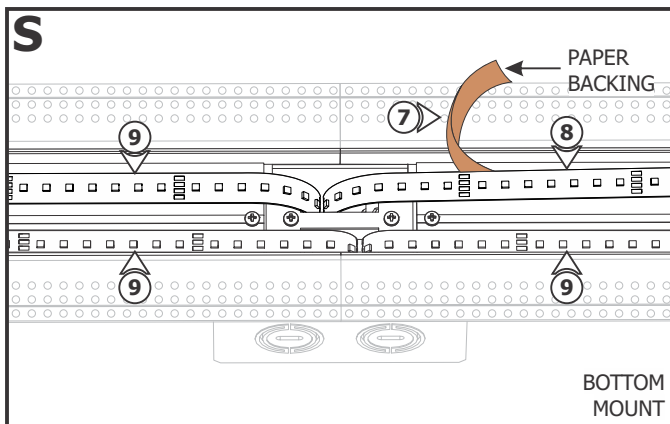

7: Carefully remove the backing from the LED strip, making sure not to remove the tape from the strip.

8: Firmly press down the adhesive portion of the LED strip onto the channel surface while removing the rest of the backing, making sure there are no air bubbles that can cause surface irregularities.

9: Repeat steps 7 and 8 for each LED strip.

10: If feeding one direction, trim excess soft strips from other power feeds **ONLY** at dashed cutting lines and overlap them with the other soft strips at power connection to avoid dark spots in the installation.

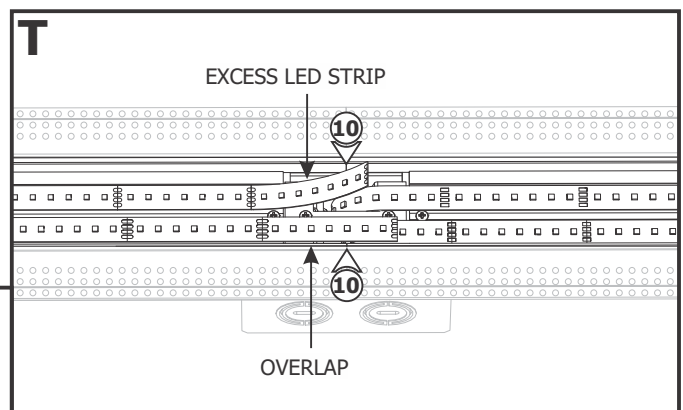

Section Five: Alternate LED Soft Strip Installation on Bottom of Channel

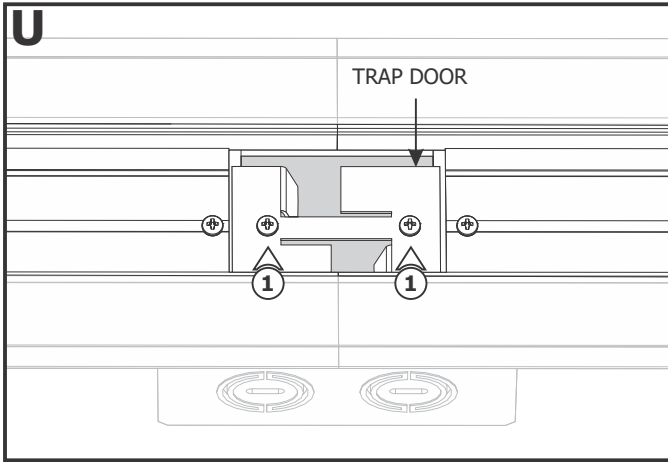

1: Attach the bent trap doors to the Center Feed Power Connector with the two provided screws.

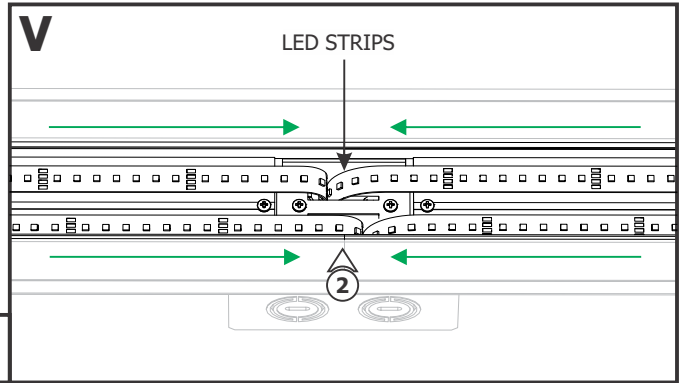

2: Route excess LED strips from other power feeds into the junction box.

Section Six: Lenses

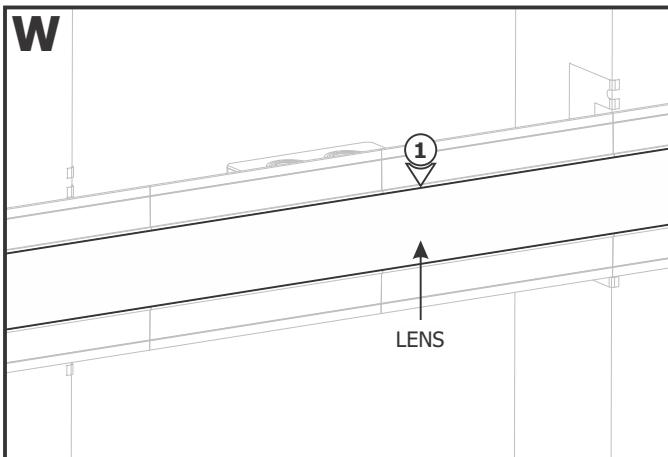

1: To avoid seams and light leaks, use the whole lens to cover the Center Power Feed along with the rest of the installed channels. Discard the precut lens that was provided with the Center Power Feed Channel.