



1718 W. Fullerton Chicago, IL 60614
 Ph: 773.770.1195 • Fax: 773.935.5613
 www.PureEdgeLighting.com • info@PureEdgeLighting.com
 © 2016 PureEdge Lighting. All Rights Reserved.

Installation Instructions for TruLine 1A End Feed Power Channel Connector

TL1A-EP_

IMPORTANT INFORMATION

- This instruction must be used concurrently with other TruLine 1A DIY installation instructions.
- This product is wall or ceiling mount.
- This instruction shows a typical installation.

SAVE THESE INSTRUCTIONS!



Section One: Install the Junction Box

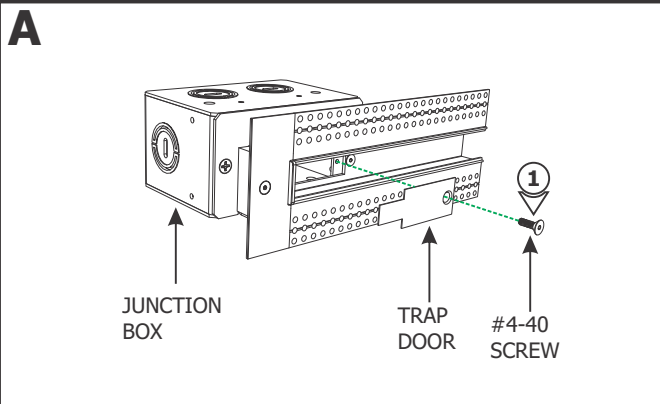

1: Remove the #4-40 screw from the junction box to remove the trap door from the assembly using a 1/16" Allen wrench.

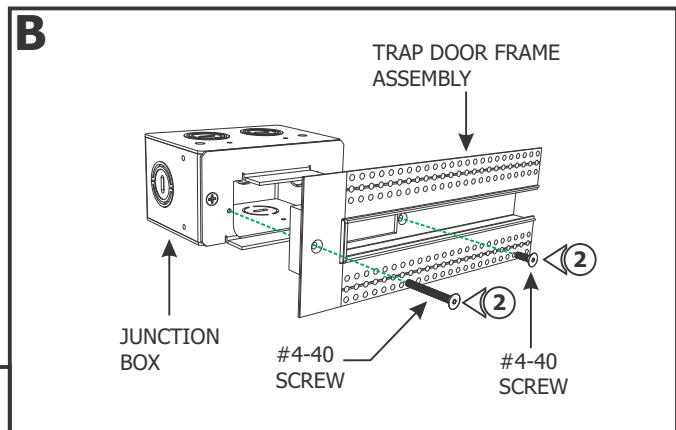

2: Remove the #4-40 screws to remove the trap door frame assembly from the junction box using a 1/16" Allen wrench.

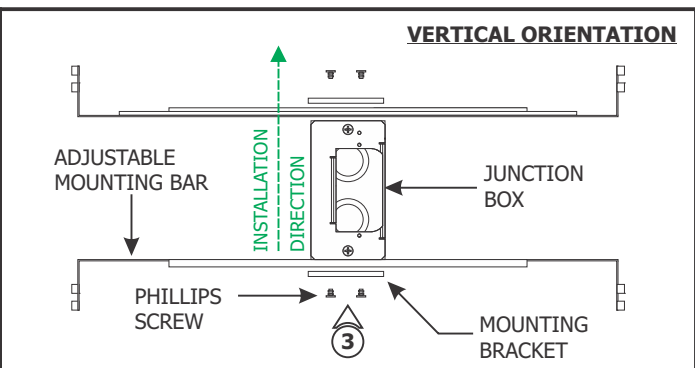
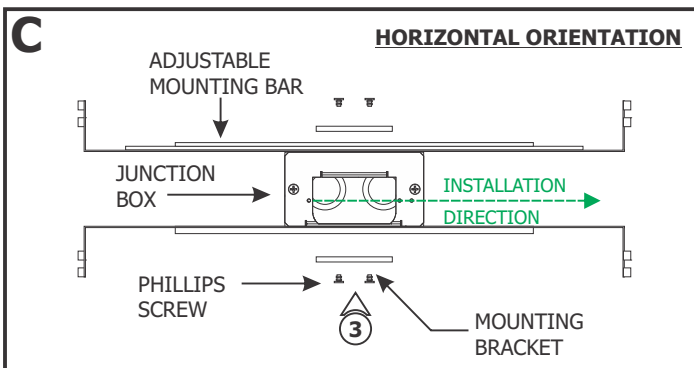

3: Mount each adjustable mounting bar to one side of the junction box and secure them with the mounting brackets and two Phillips screws provided.

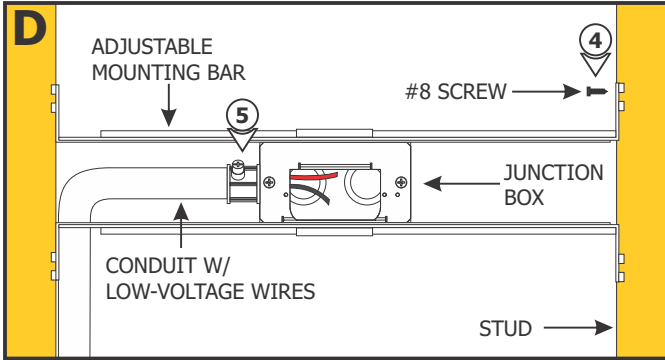

NOTE: The adjustable mounting bars mount to studs that are spaced 15" to 24" apart. If the span needs to be shorter than 15", then break the bar arms from dedicated lines.

4: Place the lips on the adjustable mounting bars against the studs. Secure the adjustable bars to the studs with the #8 screws.

5: Install conduit(s) (if required by local electrical code) and run the 24VDC low voltage wires coming from the power supply or DMX controller to the junction box. Refer to the instructions provided with the power supply.

6: Cut a section of drywall using a 6" fixed jab saw or other appropriate tool to expose the mounting plate area. Install the drywall.

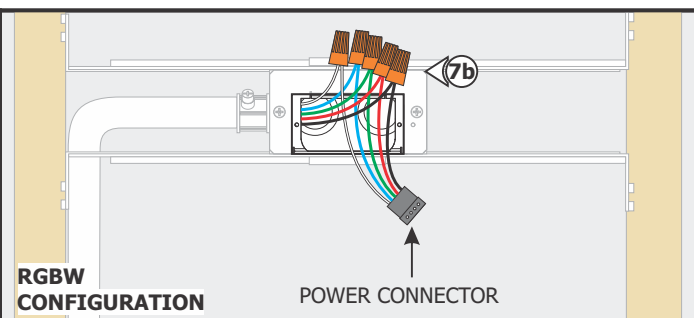
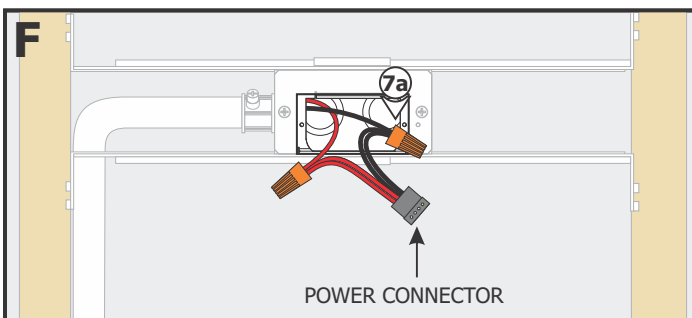
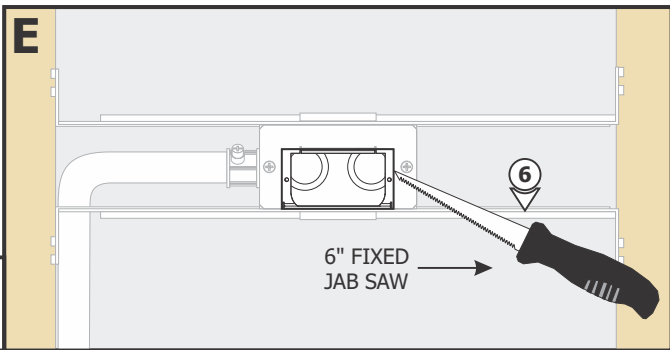

NOTE: Remote power supply wires must be present in junction box. Refer to instructions provided with power supply.

7a: Connect the red low voltage wire of the power supply to the red wires of the power connector with a wire nut. Connect the black low voltage wire of the power supply to the black wires of the power connect with a wire nut.

7b: For RGBW Configurations, connect the black, red, green, blue, and white wires of the DMX controller respectively to the black, red, green, blue, and white wires of the power connector with wire nuts.

8: Place all wire nut connections inside the junction box.

CAUTION: Unroll the entire LED strip from the reel and use the power connector to power the strip making sure there is no outage before continuing with the installation. Afterwards, carefully roll the LED strip loosely back into the reel.

Section Two: Prepare and Install the End Feed Power Connector

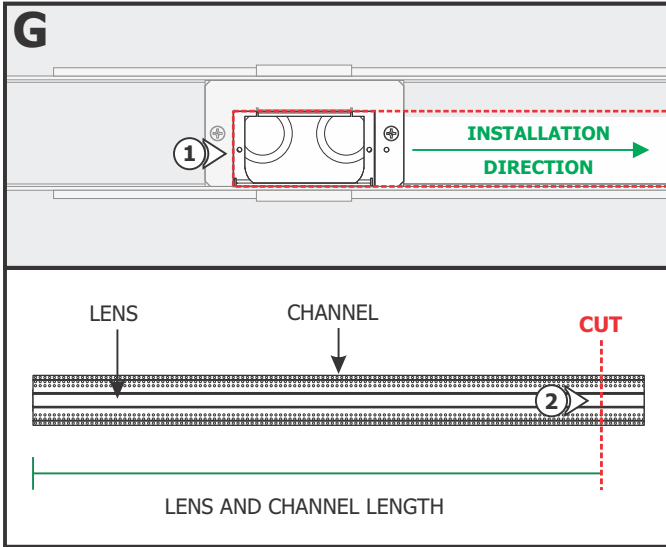

- 1: Mark and cut out the area where the installation will be located using the junction box opening as a guide (MIN 1.25").
- 2: Refer to Section One in the TruLine 1A Channel and Lens instructions to measure and cut the channel and lens before continuing.

- 3: Loosen the two #4-40 set screws on the end cap with a 0.05" Allen wrench to remove the end cap and end cap insert from the assembly.

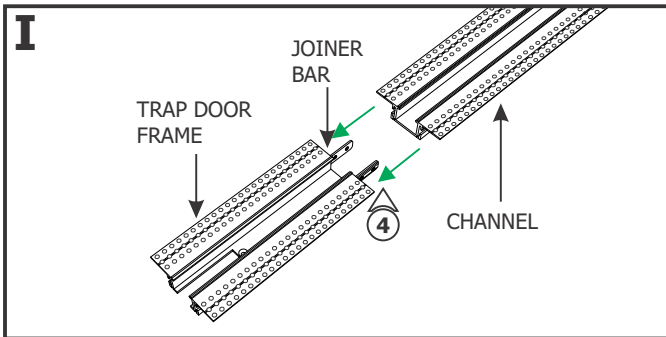
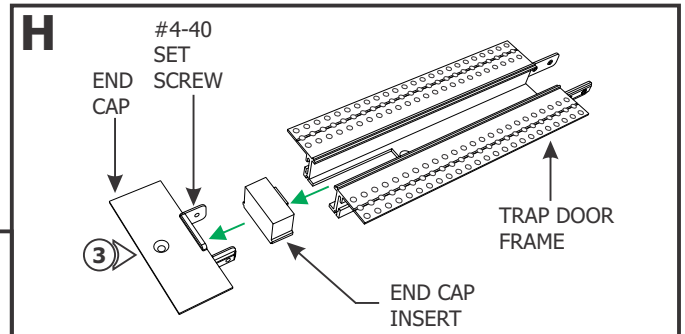

- 4: Slide a channel onto the joiner bars and tighten the remaining M3 set screws using a 1.5mm Allen wrench.

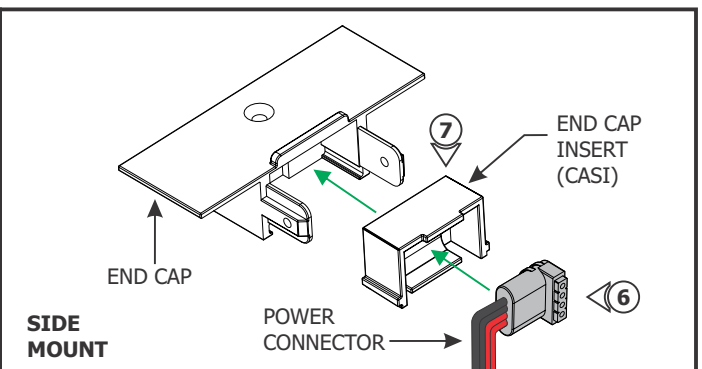
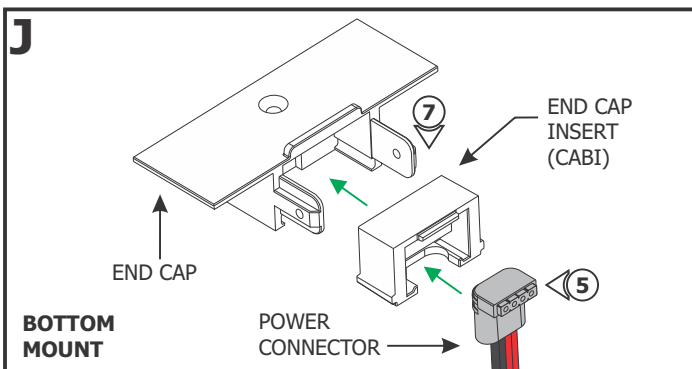

- 5: For installations where the LED Soft Strip will be laid on the bottom of the channel, place the power connector into the end cap insert (CABI).
- 6: For installations where the LED Soft Strip will be laid on the side of the channel, rotate the connector and bend the power connection wires to place the power connector into the end cap insert (CASI).
- 7: Slide the end cap insert and power connector into the end cap.

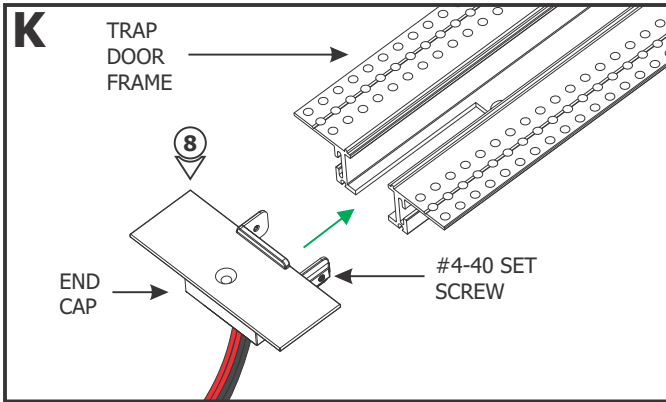

8: Insert the end cap into the TruLine 1A trap door frame and tighten the two #4-40 set screws with a 0.05" Allen wrench.

9: Place the assembled channel to the drywall cutout. Attach the assembled trap door frame and channel to the junction box using the #4-40 screws.

NOTE: Refer to the TruLine 1A Channel and Lens instructions to plaster before continuing.

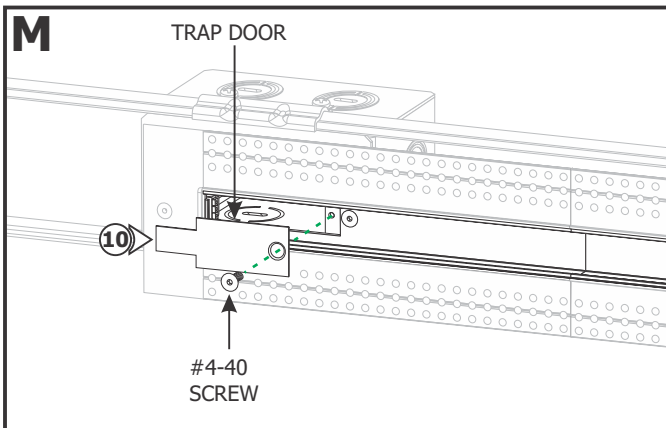
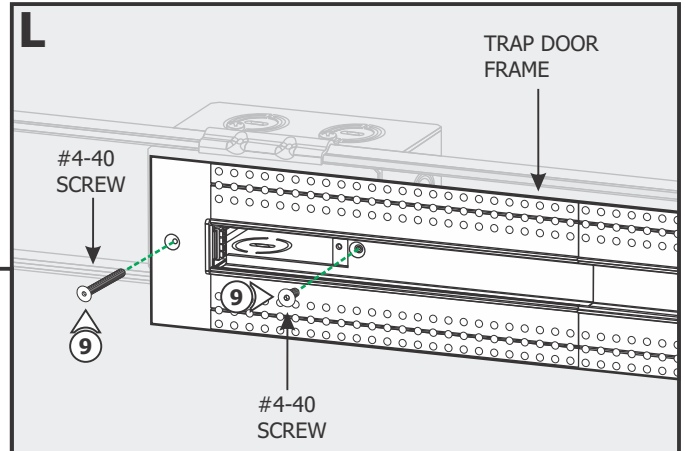

10: Replace the trap door and secure using the #4-40 screw with a 1/16" Allen wrench.

Section Three: Install the LED Soft Strip

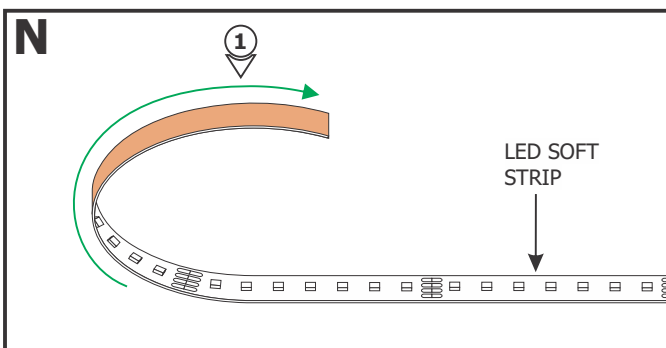

1: Gently uncoil the LED Soft Strip before applying to the channel otherwise the strip may lift off of the surface.

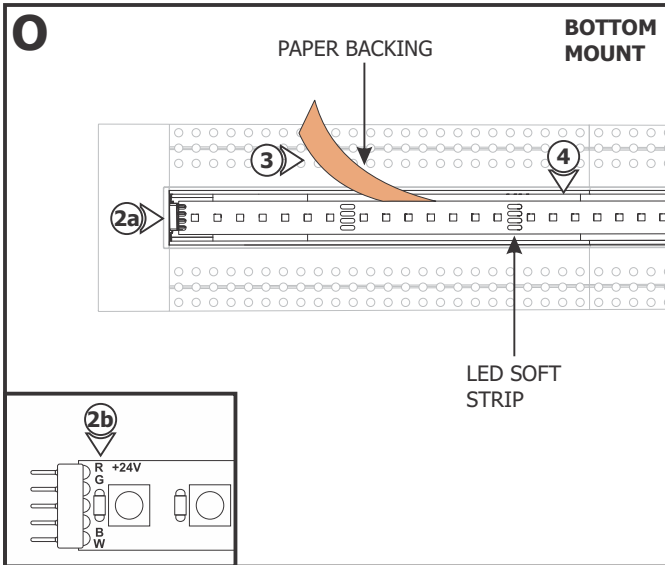

Power Feed Installation: Bottom Mount

2a: Line up the red wire side of the power connector with the "+24VDC" marking on the LED Soft Strip. Push the male connector of the LED Soft Strip into the female connector of the power connector.

2b: For RGBW Configurations, align the "RGBW" markings on the LED Soft Strip with the corresponding wires of the power connector. Push the male connector of the strip into the power connector.

3: Carefully remove the backing from the LED Soft Strip, making sure not to remove the tape from the LED Soft Strip.

4: Firmly press down the adhesive portion of the LED Soft Strip onto the channel surface while removing the rest of the backing, making sure there are no air bubbles that can cause surface irregularities.

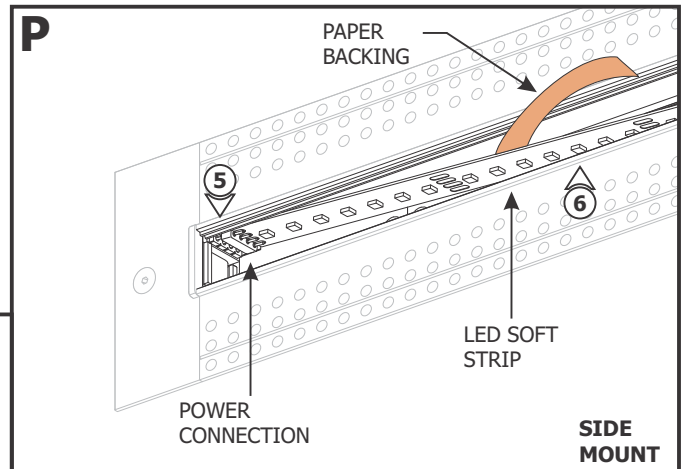

Alternate Power Feed Installation: Side Mount

5: Install the LED Soft Strip to the side of the connector.

6: Repeat steps 1 through 4 to properly install the LED Soft Strip on the side of the End Feed Power Connector.

Section Four: Lenses

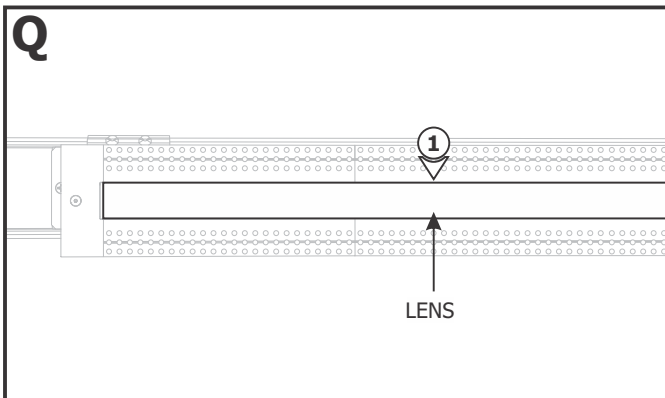

1: To avoid seams and light leaks, use the whole lens to cover the End Feed Power along with the rest of the installed channels. Discard the precut lens that was provided with the End Power Feed.